

JONATHAN CRARY

SUSPENSIONS OF PERCEPTION
ATTENTION, SPECTACLE, AND MODERN CULTURE

First MIT Press paperback edition, 2001

© 1999 Massachusetts Institute of Technology

All rights reserved. No part of this book may be reproduced in any form by any electronic or mechanical means (including photocopying, recording, or information storage and retrieval) without permission in writing from the publisher.

This book was set in ITC Garamond by Graphic Composition, Inc., and was printed and bound in the United States of America.

Library of Congress Cataloging-in-Publication Data

Crary, Jonathan.

Suspensions of perception : attention, spectacle, and modern culture / Jonathan Crary.

p. cm.

"An October book."

Includes bibliographical references and index.

ISBN , 0-262-53199-2 (pb)

1. Selectivity (Psychology) 2. Perception. 3. Attention.
4. Subjectivity. I. Title.

BF378.S45C73 1999

153.7—dc21

99-26071

CIP

10 9 8 7 6 5 4

Contents

<i>Acknowledgments</i>	ix
<i>Introduction</i>	1
ONE Modernity and the Problem of Attention	11
TWO 1879: Unbinding Vision	81
THREE 1888: Illuminations of Disenchantment	149
FOUR 1900: Reinventing Synthesis	281
Epilogue 1907: Spellbound in Rome	361
<i>Bibliography</i>	371
<i>Illustration Credits</i>	381
<i>Index</i>	383

Acknowledgments

During the writing of this book, the opportunity to test out my ideas in lectures and articles was invaluable, and I'm especially grateful to those individuals who invited and welcomed me as a speaker and to those who provided a forum for my work in publications, including Peter Galison, Caroline Jones, Alan Trachtenberg, Charles Musser, Annabel Wharton, Carol Irving, Ronald Jones, Brian Lukacher, Molly Nesbit, Vanessa Schwartz, Leo Charney, Ewa Lajer-Burcharth, Norman Bryson, Giuliana Bruno, Victor Brombert, P. Adams Sitney, Sarah Bayliss, Hannah Feldman, Russell Ferguson, Jack Barth, Ron Clark, Ellen Wardell Lee, Akira Asada, Mark Jarzombek, Sara Beliveau, Lynne Cooke, Olivier Asselin, Richard Roth, Marc Gotlieb, Cynthia Hammond, Miwon Kwon, Daniel Soutif, André Rouillé, André Gunthert, Xavier Costa, Ruth Meyer, Hans Belting, Friedrich Kittler, Horst Bredekamp, Gary Smith, and the editors of *October*. I'm particularly appreciative of the invitation from the Art History Department at Duke University to be their 1995 Benenson Lecturer: the five lectures I delivered at Duke in November of that year provided the basis for what eventually became the present text.

Many friends and colleagues offered insights, shared their expertise, or furnished support of kinds far too varied to specify here, including Suzanne Jackson, Michel Feher, Hal Foster, Leo Steinberg, Andreas Huyssen, David J. Levin, Nina Rosenblatt, Martin Meisel, Henri Zerner, Greg Lynn, John Rajchman, Sarah Lawrence, John Elderfield, Irving Lavin, Anne Boyman, Peter Eisenman, Laura Foster, Martin Jay, Catherine de Zegher, Manny Farber, Meaghan Gale, Cliff Simms, Richard Martin, Deirdre Donohue, Bridget Evans, Deena Jospe, Dominique Auzel, Tom Levin, Stephanie Schwartz, Ramona Naddaff, Richard Berman, Stephany Gordon, Kalman Bland, Kevin Parker, Kate Rudy, and Paul Wing. Special thanks to Stefan Richter and Rebeccah Blum for their kindness and hospitality in Berlin.

Introduction

This book is based on the assumption that the ways in which we intently listen to, look at, or concentrate on anything have a deeply historical character. Whether it is how we behave in front of the luminous screen of a computer or how we experience a performance in an opera house, how we accomplish certain productive, creative, or pedagogical tasks or how we more passively perform routine activities like driving a car or watching television, we are in a dimension of contemporary experience that requires that we effectively cancel out or exclude from consciousness much of our immediate environment. I am interested in how Western modernity since the nineteenth century has demanded that individuals define and shape themselves in terms of a capacity for “paying attention,” that is, for a disengagement from a broader field of attraction, whether visual or auditory, for the sake of isolating or focusing on a reduced number of stimuli. That our lives are so thoroughly a patchwork of such disconnected states is not a “natural” condition but rather the product of a dense and powerful remaking of human subjectivity in the West over the last 150 years. Nor is it insignificant now at the end of the twentieth century that one of the ways an immense social crisis of subjective dis-integration is metaphorically diagnosed is as a deficiency of “attention.”

Much critical and historical analysis of modern subjectivity during this century has been based on the idea of “reception in a state of distraction,” as articulated by Walter Benjamin and others. Following from such work has been a widespread assumption that, from the mid-1800s on, perception is fundamentally characterized by experiences of fragmentation, shock, and dispersal. I argue that modern distraction can only be understood through its reciprocal relation to the rise of attentive norms and practices. I will explore the paradoxical intersection, which has existed in many ways since the later nineteenth century, between an imperative of a concentrated attentiveness within the disciplinary organization of

labor, education, and mass consumption and an ideal of sustained attentiveness as a constitutive element of a creative and free subjectivity. No doubt some will respond that I am comparing qualitatively different notions of attention: that, for example, a cultivated individual gazing on a great work of art could have little or nothing in common with a factory worker concentrating on the performance of some repetitive task. However, as I will argue, the very possibility in the late nineteenth century of concepts of a purified aesthetic perception is inseparable from the processes of modernization that made the problem of attention a central issue in new institutional constructions of a productive and manageable subjectivity. What I hope to suggest are the ways in which modern experiences of social separation and of subjective autonomy are both intertwined within the resplendent possibilities, ambivalent limits, and failures of an attentive individual.

This book is an attempt to sketch some outlines of a genealogy of attention since the nineteenth century and to detail its role in the modernization of subjectivity. More concretely, I will examine how ideas about perception and attention were transformed in the late nineteenth century alongside the emergence of new technological forms of spectacle, display, projection, attraction, and recording. I attempt to describe ways in which new knowledge about the behavior and makeup of a human subject coincided with social and economic shifts, with new representational practices, and with a sweeping reorganization of visual/auditory culture. In this book I construct a relatively unfamiliar vantage point from which to study a generalized crisis in perception in the 1880s and 1890s and in doing so to indicate how the contested notion of attention was central to a range of social, philosophical, and aesthetic issues during those years and, indirectly, to subsequent developments in the twentieth century.

There are several important reasons why I have chosen the problem of attention as a frame through which to examine a group of objects in this historical period. Perhaps most significantly, attention, as a constellation of texts and practices, is much more than a question of the gaze, of looking, of the subject only as a spectator. It allows the problem of perception to be extracted from an easy equation with questions of visibility, and I will argue that the modern problem of attention encompasses a set of terms and positions that cannot be construed simply as questions of opticality. In recent years, within the expanding study of visibility, vision has too often been posed as an autonomous and self-justifying problem. Privileging the category of visibility runs the risk of ignoring the forces of specialization and separation that allowed such a notion to become the intellectually available concept that it is today. So much of what seems to constitute a domain

of the visual is an *effect* of other kinds of forces and relations of power. At the same time “visuality” can easily veer into a model of perception and subjectivity that is cut off from richer and more historically determined notions of “embodiment,” in which an embodied subject is both the location of operations of power and the potential for resistance. At the present moment, to assert the centrality or “hegemony” of vision within twentieth-century modernity no longer has much value or significance at all. Thus, as I will argue, spectacular culture is not founded on the necessity of making a subject *see*, but rather on strategies in which individuals are isolated, separated, and *inhabit time* as disempowered. Likewise, counter-forms of attention are neither exclusively nor essentially visual but rather constituted as other temporalities and cognitive states, such as those in trance or reverie.

One of the aims of my book *Techniques of the Observer* was to show how historical transformations in ideas about vision were inseparable from a larger reshaping of subjectivity that concerned not optical experiences but processes of modernization and rationalization. In the present book, which studies a very different field of events, one of my goals is to demonstrate how within modernity vision is only one layer of a body that could be captured, shaped, or controlled by a range of external techniques; at the same time, vision is only one part of a body capable of evading institutional capture and of inventing new forms, affects, and intensities. I do not believe that exclusively visual concepts such as “the gaze” or “beholding” are in themselves valuable objects of historical explanation.¹ My use of the problematic term “perception” is primarily a way of indicating a subject definable in terms of more than the single-sense modality of sight, in terms also of hearing and touch and, most importantly, of irreducibly *mixed* modalities which, inevitably, get little or no analysis within “visual studies.” At the same time I want to suggest how late nineteenth-century investigations of perception were heavily invested in restoring to it some of its original Latin resonances—the sense of perception as “catching” or “taking captive,” even as the impossibility of such fixedness or possession became clear. In fact, by the 1880s, perception, for many, was synonymous with “those sensations to which attention has been turned.”²

Part of the importance of the historical problem of attention lies in how it is a hinge between issues raised in the most influential modern philosophical

1. See the remarkable antivisual account of the gaze in Jean Starobinski, *The Living Eye*, trans. Arthur Goldhammer (Cambridge: Harvard University Press, 1989), pp. 2–7.

2. Theodor Ziehen, *Introduction to Physiological Psychology* [1891], trans. C. C. Van Liew (London: Sonnenschein, 1895), p. 241.

reflections on vision and perception (e.g., by Jacques Derrida, Maurice Blanchot, Georges Bataille, and Jacques Lacan) and in work on modern effects of power, on social and institutional constructions of experience and subjectivity (e.g., by Michel Foucault or Walter Benjamin). The first category, very generally, shares a related transhistorical insistence on a fundamental absence at the heart of seeing, on the impossibility of the perception of presence, or of an unmediated visual access to a plenitude of being. I contend, however, that attention becomes a specifically modern problem only because of the *historical* obliteration of the possibility of thinking the idea of presence in perception; attention will be both a simulation of presence and a makeshift, pragmatic substitute in the face of its impossibility. In *Techniques of the Observer* I showed how the rise of physiological optics in the early nineteenth century displaced models of vision that had been predicated on the self-presence of the world to an observer and on the instantaneity and atemporal nature of perception. In this book I examine some of the *consequences* of that shift: in particular the emergence of attention as a model of how a subject maintains a coherent and practical sense of the world, a model that is not primarily optical or even veridical.³ Normative explanations of attentiveness arose directly out of the understanding that a full grasp of a self-identical reality was not possible and that human perception, conditioned by physical and psychological temporalities and processes, provided at most a provisional, shifting approximation of its objects.

Thus, it is important to emphasize that an immense social remaking of the observer in the nineteenth century proceeds on the general assumption that perception cannot be thought of in terms of immediacy, presence, punctuality. Much recent critical theory, derived from a now pointless critique of presence, has been unable to fathom that whether or not one has direct perceptual access to self-presence is intrinsically irrelevant within modern disciplinary and spectacular culture. What is important to institutional power, since the late nineteenth century, is simply that perception function in a way that insures a subject is productive, manageable, and predictable, and is able to be socially integrated and adaptive. The realization that attention had limits beyond and below which productivity and social cohesion were threatened created a volatile indistinction between newly designated “pathologies” of attention and creative, intensive states of deep absorption and daydreaming. Attention, as I will detail, was an inevitable ingredient of a

3. “A good psychology of attention does not have to include ‘seeing’ as a theoretical term.” Harold Pashler, *The Psychology of Attention* (Cambridge: MIT Press, 1998), p. 9.

subjective conception of vision: attention is the means by which an individual observer can transcend those subjective limitations and make perception *its own*, and attention is at the same time a means by which a perceiver becomes open to control and annexation by external agencies.

This, briefly, is part of the intellectual scope of this project. Its concrete parameters, however, are more circumscribed. Even though I stake out a period of roughly twenty-five years, from 1879 to the very early 1900s, I do not attempt in any sense to write a history or survey of ideas or practices of perception during this time. Beginning with chapter one, I attempt to establish both why attention became a decisively new kind of problem in the nineteenth century, far removed from previous historical understandings of it, and why it became inseparable from philosophical, psychological, and aesthetic investigations of perception. Also, I outline how the many, often conflicting efforts to explain attention empirically, and to render it manageable, were ultimately unsuccessful. Throughout the following chapters I create some provisional diagrams of those last decades of the nineteenth century, diagrams assembled out of local analyses of a relatively small number of objects through which to consider the interrelated problem of perception and modernization. Although the sequence of my chapters is organized chronologically, beginning with objects from around 1879, my actual presentation is discontinuous in that I construct three relatively autonomous analyses slicing across that historical continuum.

Each of my chapters presents a constellation of objects that suggest some of the ways in which the problems of a contingent modernized perception took shape within the larger transformation of Western cultural practices in the late nineteenth and early twentieth centuries. More specifically, each of these constellations includes some of the important forms of machine vision and techniques for the simulation of continuous movement, which were obvious components of many reconceptualizations of perception as well as central elements in an incipient reshaping of mass culture. An enduring critical problem has long been how to understand ways in which film and modernist art occupy a common historical ground. I have attempted to balance any generalizing speculation with highly specific analyses of concrete practices and objects, but at the same time I have sought to avoid shaping these in the service of “illustrating” or proving any particular thesis about the historical processes I am investigating. Probably the most important explanatory choice that I’ve made, however, has been to foreground a single work of art as a pivot around which each chapter is constructed. These primary works are *In the Conservatory* by Manet from 1879, *Parade de cirque* by Seurat



Edouard Manet, *In the Conservatory*, 1879.

from 1887–1888, and *Pines and Rocks* by Cézanne from around 1900, and hence each chapter is a generally synchronic presentation of objects segmented by roughly ten-year intervals along the diachronic axis of the book.

In *Techniques of the Observer* I challenged conventional accounts that saw modernist painting of the 1870s and 1880s, in various ways, as constituting an epochal turning point in the historical makeup of the observer and practices of vision, and I certainly reaffirm that position here. That is, visual modernism took shape within *an already reconfigured field* of techniques and discourses about visuality and an observing subject. But this scarcely means these artworks should go unexamined. They are objects through which I investigate the *consequences*



Georges Seurat, Parade de cirque, 1887–1888.

and reverberations of the rise of subjective and physiological models of vision earlier in the nineteenth century, and they are central to any consideration of the new creative horizons as well as constraints produced by this historical transformation. However, that I am placing artworks so prominently within this project is not to afford them any sort of ontological privilege. My book proceeds from a counter assumption: I am developing the issue of attention in order to question the relevance of isolating an aesthetically determined contemplation or absorption. The field of attentive practices offers a single heterogeneous surface on which discursive objects, material practices, and representational artifacts do not occupy qualitatively different strata but are equally involved in the production of effects of power and new types of subjectivities. Thus I am not interested in recovering a primary or “authentic” meaning that is somehow immanent to these works; rather,



Paul Cézanne, Pines and Rocks, c. 1900.

by examining them I hope to construct some of the field of their *exterior*; to multiply the links to this exterior, “to remain attentive to the plural” of these paintings, where “everything signifies ceaselessly and several times.”⁴

However, my intention is not to position, for example, a work by Seurat as either symptomatic of or determined by any of the discursive objects and institutional spaces to which I refer. I am insisting that certain works, and the specific aesthetic practices on which they are founded, are *constitutive* elements of that same field of events, that they are *original* fashionings of related problems. Thus the use of Manet, Seurat, and Cezanne as figures through whom to rethink developments in this period is hardly arbitrary. Each of them engaged in a singular confrontation with the disruptions, vacancies, and rifts within a perceptual field; each of them made unprecedented discoveries about the indeterminacy of an attentive perception but also how its instabilities could be the basis for a reinvention of perceptual experience and of representational practices. Monet, and to a lesser extent Degas, could well have been included but were omitted in the interest of controlling the size of the project. The reason for the choice of the specific paintings will become clear in the terms of my discussion, but briefly what they have in common is an engagement with a general problem of perceptual synthesis and with the interrelated binding and disintegrative possibilities of attention. At the same time, I’m interested in how these space-drained (but hardly flat) images are inseparable from emerging machine forms of “realism” and optical verisimilitude.

I do not need to emphasize that this book is finally less about art than about a rethinking and reconstruction of perception in which art practices were significant but hardly paramount or exclusive components. Thus I have tended to uproot these paintings from some of their familiar art historical frameworks and have bracketed any significant “vertical” explanations of artworks in terms of their relation to breaks or continuities along a linear historical trajectory of movements and styles. Instead, following Gilles Deleuze and others, I have emphasized transversal connections between objects of different kinds occupying very different locations. Deleuze’s proposition that “philosophy, art and science come into relations of mutual resonance and exchange, but always for internal reasons,” provides a way of thinking of the simultaneous but autonomous coexistence of disparate cultural artifacts, outside of mechanical or biographical notions of influence and worn-out distinctions between “high” and “low” culture.⁵

4. Roland Barthes, *S/Z*, trans. Richard Miller (New York: Hill and Wang, 1974), pp. 11–12.

5. Gilles Deleuze, *Negotiations* (New York: Columbia University Press, 1995), p. 125.

The value of this book's title is as much in evocation as description: important for me are several resonances of the word *suspension*. First, I want to suggest the state of being suspended, a looking or listening so rapt that it is an exemption from ordinary conditions, that it becomes a suspended temporality, a hovering out of time. The roots of the word *attention* in fact resonate with a sense of "tension," of being "stretched," and also of "waiting." It implies the possibility of a fixation, of holding something in wonder or contemplation, in which the attentive subject is both immobile and ungrounded. But at the same time a suspension is also a cancellation or an interruption, and I wanted here to indicate a disturbance, even a negation of perception itself. For throughout the book I am concerned with the idea of a perception that can be both an absorption *and* an absence or deferral. It is this contradictory composition of perception that I will examine here, not by portentously identifying it as part of the eternal ruses of vision, but by exploring the conditions of possibility for its historical emergence. Perhaps it is unnecessary for me to propose that the archaeology of these conditions is synonymous with the prehistory of our own present and its techno-institutional worlds.

ONE
Modernity and the
Problem of Attention

The constant continuity of the process, the unobstructed and fluid transition of value from one form into the other, or from one phase of the process into the next, appears as a fundamental condition for production based on capital.

—Karl Marx, *Grundrisse*

Almost all the problems of philosophy once again pose the same form of question as they did two thousand years ago: how can something originate in its opposite, for example rationality in irrationality, the sentient in the dead, logic in unlogic, disinterested contemplation in covetous desire, living for others in egoism, truth in error?

—Friedrich Nietzsche, *Human, All Too Human*

One of the most important nineteenth-century developments in the history of perception was the relatively sudden emergence of models of subjective vision in a wide range of disciplines during the period 1810–1840. Dominant discourses and practices of vision, within the space of a few decades, effectively broke with a classical regime of visuality and grounded the truth of vision in the density and

materiality of the body.¹ One of the consequences of this shift was that the functioning of vision became dependent on the complex and contingent physiological makeup of the observer, rendering vision faulty, unreliable, and, it was sometimes argued, arbitrary. Even before the middle of the century, an extensive amount of work in science, philosophy, psychology, and art involved a coming to terms in various ways with the understanding that vision, or any of the senses, could no longer claim an essential objectivity or certainty. By the 1860s, the scientific work of Hermann von Helmholtz, Gustav Fechner, and many others had defined the contours of a general epistemological uncertainty in which perceptual experience had lost the primal guarantees that once upheld its privileged relation to the foundation of knowledge. This book examines some of the components of a cultural environment in which these new truths and new uncertainties about perception were being contested and reconstructed, within both visual modernism and a modernizing mass visual culture, beginning in the late 1870s.

The idea of subjective vision—the notion that our perceptual and sensory experience depends less on the nature of an external stimulus than on the composition and functioning of our sensory apparatus—was one of the conditions for the historical emergence of notions of autonomous vision, that is, for a severing (or liberation) of perceptual experience from a necessary relation to an exterior world. Equally important, the rapid accumulation of knowledge about the workings of a fully embodied observer disclosed possible ways that vision was open to procedures of normalization, of quantification, of discipline. Once the empirical truth of vision was determined to lie in the body, vision (and similarly the other senses) could be annexed and controlled by external techniques of manipulation and stimulation. This was the decisive achievement of the science of psychophysics in the mid-nineteenth century, which, by apparently rendering sensation measurable, embedded human perception in the domain of the quantifiable and the abstract. Vision, conceived in this way, became compatible with many other processes of modernization, even as it also opened up the possibility of visual experience that was intrinsically nonrationalizable, that exceeded any procedures of normalization. These developments are part of a critical historical turning point in the second half of the nineteenth century at which any significant qualitative difference between life and technics begins to evaporate. The disintegration of an indis-

1. See my *Techniques of the Observer: On Vision and Modernity in the Nineteenth Century* (Cambridge: MIT Press, 1990). Extrapolating from the work of Foucault, I use the word *classical* to describe theories and practices of vision during the period 1660–1800, which persisted in partial forms well into the nineteenth century.

putable distinction between interior and exterior becomes a condition for the emergence of spectacular modernizing culture and for a dramatic expansion of the possibilities of aesthetic experience. The relocation of perception (as well as processes and functions previously assumed to be “mental”) in the thickness of the body was a precondition for the instrumentalizing of human vision as a component of machinic arrangements; but it also stands behind the astonishing burst of visual invention and experimentation in European art in the second half of the nineteenth century.

More specifically since the late nineteenth century, and increasingly during the last two decades, capitalist modernity has generated a constant re-creation of the conditions of sensory experience, in what could be called a revolutionizing of the means of perception. For the last 100 years perceptual modalities have been and continue to be in a state of perpetual transformation, or, some might claim, a state of crisis. If vision can be said to have any enduring characteristic within the twentieth century, it is that it has no enduring features. Rather it is embedded in a pattern of adaptability to new technological relations, social configurations, and economic imperatives. What we familiarly refer to, for example, as film, photography, and television are transient elements within an accelerating sequence of displacements and obsolescences, part of the delirious operations of modernization.

At the moment when the dynamic logic of capital began to dramatically undermine any stable or enduring structure of perception, this logic simultaneously attempted to impose a disciplinary regime of attentiveness. For it is in the late nineteenth century, within the human sciences and particularly the nascent field of scientific psychology, that the problem of *attention* becomes a fundamental issue.² It was a problem whose centrality was directly related to the emergence of a social, urban, psychic, and industrial field increasingly saturated with sensory input. Inattention, especially within the context of new forms of large-scale industrialized production, began to be treated as a danger and a serious problem, even though it was often the very modernized arrangements of labor that produced inattention.³ It is possible to see one crucial aspect of modernity as an ongoing

2. As my friends and close colleagues well know, I've been engaged with the historical and cultural problem of attention since the late 1980s, initially setting up some of the terms of my interests in “Attention, Spectacle, Counter-Memory,” *October* 50 (Fall 1989), pp. 97–107. Early sections of the present chapter and parts of chapter two appeared as “Unbinding Vision,” *October* 68 (Spring 1994), pp. 21–44; and my “Attention and Modernity in the Nineteenth Century” was included in Caroline Jones and Peter Galison, eds., *Picturing Science, Producing Art* (New York: Routledge, 1998), pp. 475–499.

3. Marx discusses how, even by the 1840s, factory management understood that “the extent of vigilance and attention on the part of the workmen was hardly capable of being increased” and that

crisis of attentiveness, in which the changing configurations of capitalism continually push attention and distraction to new limits and thresholds, with an endless sequence of new products, sources of stimulation, and streams of information, and then respond with new methods of managing and regulating perception. Gianni Vattimo has noted that “the intensification of communicative phenomena and the increasingly prominent circulation of information . . . are not merely aspects of modernization amongst others, but in some way the center and very sense of this process.”⁴ But at the same time, attention, as a historical problem, is not reducible to the strategies of social discipline. As I shall argue, the articulation of a subject in terms of attentive capacities simultaneously disclosed a subject incapable of conforming to such disciplinary imperatives.

Since Kant, part of the epistemological dilemma of modernity has been defining a human capacity for synthesis within the fragmentation and atomization of a cognitive field. That dilemma becomes especially acute in the second half of the nineteenth century alongside the development of various techniques for imposing specific kinds of perceptual synthesis, from the mass diffusion of the stereoscope in the 1850s to early forms of cinema in the 1890s. The nineteenth century saw the steady demolition of Kant’s transcendental standpoint and its synthetic a priori categories, detailed in his first critique. Kant argued that all possible perception could occur only in terms of an original synthetic unification principle, a self-cause, that stood over and above any empirical sense experiences such as vision. “Unity of synthesis according to empirical concepts would be altogether accidental, if these latter were not based on a transcendental ground of unity. Otherwise it would be possible for appearances to crowd in upon the soul. . . . Since connection in accordance with universal and necessary laws would be lacking, all relation of knowledge to objects would fall away.”⁵ Once the philosophical guarantees of any a priori cognitive unity collapsed (or once the possibility of the self imposing its unity onto the world, in post-Kantian idealism, became untenable), the problem

shortening the working day, and thus taxing less the worker’s attentiveness, resulted in increases in productivity. See Karl Marx, *Capital*, vol. 1, trans. Samuel Moore and Edward Aveling (New York: International, 1967), pp. 410–412. On the shift from the moral discipline and paternalist organization of labor in the first half of the nineteenth century to the more rationalized management of production and time, see Michelle Perrot, “The Three Ages of Industrial Discipline in Nineteenth-Century France,” in John M. Merriman, ed., *Consciousness and Class Experience in Nineteenth-Century France* (New York: Holmes and Meier, 1979), pp. 149–168.

4. Gianni Vattimo, *The Transparent Society*, trans. David Webb (Baltimore: Johns Hopkins University Press, 1992), pp. 14–15.

5. Immanuel Kant, *Critique of Pure Reason*, trans. Norman Kemp Smith (New York: St. Martin’s, 1965), p. 138.

of “reality maintenance” gradually became a function of a contingent and merely psychological capacity for synthesis or association.⁶ Schopenhauer’s substitution of the will for Kant’s transcendental unity of apperception is an event with many aftershocks, for it implied that the perceived wholeness of the world was no longer the apodictic product of Law but depended on a potentially variable *relation of forces*, including external forces outside the subject’s control.⁷ It became imperative for thinkers of all kinds to discover what faculties, operations, or organs produced or allowed the complex coherence of conscious thought.⁸ The failure or malfunction of a capacity for synthesis, often described as dissociation, became linked in the late nineteenth century with psychosis and other mental pathologies. But what was often labeled as a regressive or pathological disintegration of perception was in fact evidence of a fundamental shift in the relation of the subject to a visual field. In Bergson’s work, for example, new models of synthesis involved the binding of immediate sensory perceptions with the creative forces of memory. Wilhelm Dilthey discussed at length the creative forms of synthesis and fusion that are specific to the activity of the human imagination. For Nietzsche synthesis was no longer the constitution of truth but rather a shifting alignment of forces that was endlessly creative and metamorphic.

The American psychologist G. Stanley Hall, writing in 1883, pessimistically reflected on the repercussions of accepting this contingency as a condition of knowledge: “Does life cultivate the mind only in spots or nodes, and are these so imperfectly bound together by associative and apperceptive processes that special stress upon one of them causes it to isolate itself still more till the power of self-direction is lost, and devolution and disintegration slowly supervene?”⁹ For institutional psychology in the 1880s and 1890s, part of psychic normality was the ability

6. Victor Cousin exemplifies a wider sense of dismay at the rise of “psychological” explanation within epistemology: “Now as soon as the laws of reason are degraded to being nothing but laws relative to the human condition, their whole compass is circumscribed by the sphere of our personal nature, and their widest consequences, always marked with an indelible character of subjectivity, engender only irresistible persuasions, if you please, but no independent truths.” Cousin, *Elements of Psychology*, trans. Caleb Henry (New York: Ivison & Phinney, 1856), pp. 419–420.

7. Arthur Schopenhauer, *The World as Will and Representation* (1844), trans. E. F. J. Payne (New York: Dover, 1966), vol. 2, p. 137.

8. By the 1850s, a range of interpretations of Kant “turned the a priori forms into ‘innate laws of the mind,’” often with a neurological substrate, according to Klaus Kohnke, *The Rise of Neo-Kantianism: German Academic Philosophy Between Idealism and Positivism*, trans. R. J. Hollingdale (Cambridge: Cambridge University Press, 1991), p. 98. Kohnke provides a valuable discussion of the persistent question of “apriority,” particularly in the work of the neo-Kantians Alois Riehl and Hermann Cohen in the 1870s.

9. G. Stanley Hall, “Reaction Time and Attention in the Hypnotic State,” *Mind* 8 (1883), pp. 171–182.

to synthetically bind perceptions into a functional whole, thereby warding off the threat of dissociation, or of what Kant saw as perceptions “crowding in upon the soul.” The German psychologist Oswald Kulpe insisted that without a capacity for attention, “consciousness would be at the mercy of external impressions . . . thinking would be made impossible by the noisiness of our surroundings.”¹⁰ The operation of vision itself, with all its physiological idiosyncrasies and inconsistencies, was not sufficiently lawlike to function reliably without the “juridical” intervention of attention to hold together sensory data.¹¹

The anti-modernist Max Nordau was one of the most widely read writers to link a failure of attentiveness with sociopathic behavior, but his diatribes were not far from the social determinations underpinning the work of more sober, scientific authorities like Ribot:

Untended and unrestrained by attention, the brain activity of the degenerate and hysterical is capricious and without aim or purpose. Through the unrestricted play of association representations are called into consciousness and are free to run riot there. They are aroused and extinguished automatically; and the will does not interfere to strengthen or to suppress them. . . . Weakness or want of attention, produces, then, in the first place false judgements respecting the objective universe, respecting the qualities of things and their relations to each other. Consciousness acquires a distorted and blurred view of the external world. . . . Culture and command over the powers of nature are solely the result of attention; all errors, all superstition, the consequence of defective attention.¹²

10. Oswald Kulpe, *Outlines of Psychology* (1893), trans. Edward Bradford Titchener (London: Sonnenschein, 1895), p. 215.

11. In the 1880s, Yale psychology professor George Trumbull Ladd suggested the cognitive inadequacy of the “retinal”: “Many retinal images admit of two or more interpretations—which interpretation will be chosen depends upon a variety of circumstances that perhaps cannot all be accurately defined. . . . Anyone accustomed to studying the effect of the colored points and outlines which appear in the image seen with closed eyes by the retina’s own light, knows how apparently lawless is the interpretation given to this image. This is especially true when attention is somewhat relaxed—as, for example, on sinking into reverie or sleep. Much of the ‘stuff’ out of which the phenomena of dreams are made, may be suggested and controlled by the condition of the ‘retinal field.’ In all these cases, *only a sharper attention* and more objective view of things is needed to dispel the illusion and make us aware how scanty is the schema, as it were, out of which, by association and reproduction, we have constructed our presentations of sense.” Ladd, *Elements of Physiological Psychology* (New York: Scribner’s, 1887), pp. 446–447; emphasis added.

12. Max Nordau, *Degeneration* (1892; New York: Appleton, 1895), p. 56. Nordau’s work had been preceded by numerous more “scientific” studies of his subject. Mental degeneration, including defective attentiveness, is discussed in the context of larger cosmic and devolutionary processes of decline

Attention for Nordau, and in a less extreme way for many others, was a repressive and disciplinary defense against all potentially disruptive forms of free association. The words of British psychologist James Cappie in the 1880s are perhaps more typical: “It is unnecessary to enlarge on the psychological importance of this function. It may be said to underlie every other mental faculty. It is the bringing of the consciousness to a focus in some special direction . . . without it meaningless reverie will take the place of coherent thought.”¹³ Attention thus became an imprecise way of designating the relative capacity of a subject to selectively isolate certain contents of a sensory field at the expense of others in the interests of maintaining an orderly and productive world.



Obviously notions of attention and attentiveness exist in many different places long before the nineteenth century, going back to St. Augustine and earlier, and even a summary outline of their history would be enormous.¹⁴ My aim here is simply to indicate how, in the second half of the nineteenth century, attention becomes a fundamentally new object within the modernization of subjectivity. In most cases before the nineteenth century, it had a local importance in matters of education, self-fashioning, etiquette, pedagogical and mnemonic practices, or scientific inquiry.¹⁵ Even when attention was an object of philosophical reflection,

in Henry Maudsley, *Body and Will* (New York: Appleton, 1884). Both these texts are examined in Daniel Pick, *Faces of Degeneration: A European Disorder, c. 1848–1918* (Cambridge: Cambridge University Press, 1989).

13. James Cappie, “Some Points in the Physiology of Attention, Belief and Will,” *Brain* 9 (July 1886), p. 201.

14. Augustine characterizes human attention in terms of its essential temporality, unlike divine knowledge: “Nor does God’s attention pass from one thought to another; all things which he knows are present at the same time to his incorporeal vision. He knows events in time without any temporal acts of knowledge.” *City of God*, trans. Henry Bettenson (London: Penguin, 1972), p. 452. Some Augustinian elements reappear much later in Malebranche’s discussion of attention, a discussion that is otherwise a product of the Cartesian intellectual milieu of late seventeenth-century France. In one of the great European attempts at an ontology of perception, Malebranche outlines a fundamental ambivalence about attention because it is too bound up in the passions and the senses, which can divert the mind from “contemplation of purely intelligible truths.” “Nonetheless, as the soul cannot be without passions, sensations, or some other particular modification, we must make a virtue of necessity and draw even from these modifications assistance in making ourselves more attentive.” Nicolas Malebranche, *The Search after Truth* (1675), trans. Thomas M. Lennon and Paul J. Olscamp (Cambridge: Cambridge University Press, 1997), pp. 413–418. In his essay “Time and Creation,” Cornelius Castoriadis discusses the importance of attention to the conception of subjective time in Augustine and Husserl; in Castoriadis, *World in Fragments*, trans. David Ames Curtis (Stanford: Stanford University Press, 1997), pp. 374–401.

15. Descartes’s discussion of *admiration* or wonderment in *The Passions of the Soul* defines some of the terms of a fundamentally different historical regime of attention. See *The Philosophical Writings of Descartes*, vol. 1, trans. John Cottingham et al. (Cambridge: Cambridge University Press, 1985), pp. 354–356: “Of wonder, in particular, we may say that it is useful in that it makes us learn and retain in

it was a marginal, at best secondary problem within explanations of mind and consciousness that either did not constitutively depend on it or in which it was one of a constellation of equally significant and mutually dependent faculties.¹⁶ Attention figures in Condillac's epistemology, for example, but he situates it as simply one element of many contributing to the necessarily *unified* operation of mental life, whereas in the period I am examining attention was an essential but fragile imposition of coherence and clarity onto the dispersed contents of consciousness.¹⁷ At the same time, for Condillac, attention was a matter of the *force* of a sensation, an effect of an event external to the subject. In this sense he is not altogether distinct from eighteenth-century British philosophy with its models of a mind as passive receiver of sensation, models that had no need of an idea of attention (the word is of marginal significance in the work of Locke, Hume, and Berkeley if present at all). Attention, as it was conceived in the later nineteenth century, is radically alien to an eighteenth-century notion of mental activity as a stamp or a

our memory things of which we were previously ignorant. For we wonder only at what appears to us unusual and extraordinary. . . . When something previously unknown to us comes before our intellect or our senses for the first time, this does not make us retain it in our memory unless our idea of it is strengthened in our brain by some passion, or perhaps also by an application of our intellect as fixed by our will in a special state of attention and reflection." For a superb account of this tradition of admiration/wonderment, see Lorraine Daston, "Curiosity in Early Modern Science," *Word and Image* 11, no. 4 (October–December 1995), pp. 391–404, esp. p. 401: "Seventeenth-century natural philosophers regularly paired 'inquisitive' with 'industrious'; 'attention' with 'diligence'. By the mid-eighteenth century, it had become the moral criterion by which to distinguish the serious savant from the frivolous amateur, for only the former was capable of converting 'noble curiosity' into 'work and continued application' by 'use of attention'. . . . The unswerving, penetrating attention which scientific investigation was thought to require slackened without curiosity, and curiosity was triggered by wonder. Attention screwed to this virtuoso pitch amounted to intellectual possession." See also the historicization of curiosity and attention in Krzysztof Pomian, *Collectors and Curiosities: Paris and Venice 1500–1800*, trans. Elizabeth Wiles-Portier (Cambridge: Polity, 1990), pp. 57–64; and Lorraine Daston and Katharine Park, *Wonders and the Order of Nature 1150–1750* (New York: Zone Books, 1998), pp. 311–328.

16. Referring to the work of Albrecht von Haller, Thomas Hartley, and others, Karl M. Figlio summarized a key model of eighteenth-century epistemological thought: "The understanding was built up from sensations combined by association. Sensations were focused upon by attention, which allowed the comparison of ideas derived from them. In the comparison and evaluation of two or more ideas lay the essence of reason and judgment. Imagination and memory implied the presentation, in the absence of external impressions, of ideas already preserved in the common sensory. In all these operations, the mind was determined in its actions *by the impressions thrust upon it*." Karl M. Figlio, "Theories of Perception and the Physiology of Mind in the Late Eighteenth Century," *History of Science* 7 (1975), p. 197; emphasis added.

17. Etienne Bonnot de Condillac, "Essay on the Origin of Human Knowledge," in *Philosophical Writings of Etienne Bonnot, Abbe de Condillac*, vol. 2, trans. Franklin Philip (Hillsdale, N.J.: Lawrence Erlbaum, 1987), pp. 441–455. On the function of unification as the basic role of reason, see Ernst Cassirer, *The Philosophy of the Enlightenment* (Princeton: Princeton University Press, 1951), pp. 21–27. See also the discussion of Condillac's "theatrical" model of attention and other mental operations in Suzanne Gearhart, *The Open Boundary of History and Fiction* (Princeton: Princeton University Press, 1984), pp. 161–199.

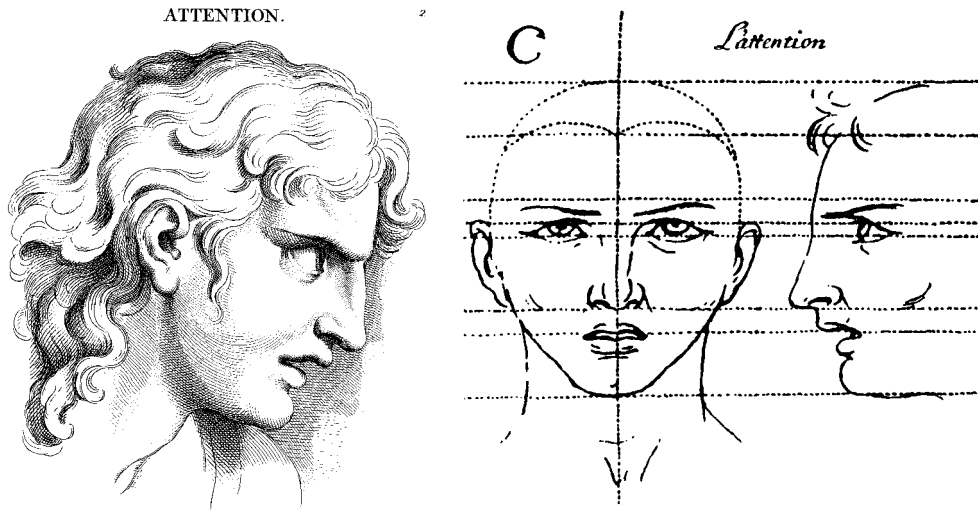

Illustrations of “Attention” from late eighteenth-century editions of Charles Le Brun’s treatise on the expression of the passions.

mold that will somehow fix or preserve the constancy of objects.¹⁸ In historical discussions of the problem of attention, one often encounters the claim that the modern psychological category of attention is continuous with notions of apperception that were important in different ways for Leibniz and Kant.¹⁹ But in fact what is crucial is the unmistakable historical discontinuity between the problem of attention in the second half of the nineteenth century and its place in European thought in previous centuries.

As I suggested earlier, there were two important conditions for the emergence of attention as a major problem in accounts of subjectivity. The first was

18. In the thousand or more pages of his *Essay*, John Locke mentions attention only briefly, as a sub-component of the faculty for *retention*. “Attention and repetition help much to the fixing any ideas in the memory” (p. 194) and “When the ideas that offer themselves . . . are taken notice of, and, as it were, registered in the memory, it is attention” (p. 299). *An Essay Concerning Human Understanding*, 1st ed. (1690), vol. 1 (New York: Dover, 1959). See Michael Baxandall’s discussion of attention in relation to the paintings of Chardin and the notion of Distinctness in Locke, in *Patterns of Intention: On the Historical Explanation of Pictures* (New Haven: Yale University Press, 1985), pp. 74–104.

19. See, for example, Gardner Murphy and Joseph K. Kovach, *Historical Introduction to Modern Psychology*, 3d ed. (San Diego: Harcourt, Brace, Jovanovich, 1972), pp. 23–24. See also the historical survey in Gary Hatfield, “Attention in Early Scientific Psychology,” in Richard D. Wright, ed., *Visual Attention* (Oxford: Oxford University Press, 1998), which finds “both continuity and divergence in the last 250 years of attention research” (p. 24).

the collapse of classical models of vision and of the stable, punctual subject those models presupposed. The second was the untenability of a priori solutions to epistemological problems. This entailed the loss of any permanent or unconditional guarantees of mental unity and synthesis. There are many places in the first decades of the nineteenth century where responses to these problems were attempted. The work of philosopher Pierre Maine de Biran, in the early nineteenth century, is particularly important for demonstrating how questions of subjectivity are inseparable from the instability and uncertainty of physiological realities. His attempts to derive some *fait primitif* of selfhood, of individual freedom, and finally of the possibility of soul from the enduring experience of active, willed effort in relation to the body established the terms for subsequent epistemological and even ethical debates.²⁰ Jan Goldstein has detailed the importance of the problem of the unity of the self for Victor Cousin and others in the 1820s, who held to the general principle “Character is unity.” Cousin’s eclecticism “combined a limited reliance on sensationalism with a priori belief in the self, or *moi*, a repository of self-initiated mental activity and free will known through introspection.”²¹ Especially during the period from 1840 to the mid-1860s, there were a variety of systemic and often convoluted attempts to propose new principles from which to deduce an effective unity of mind or thought. Usually grouped under the category of “associationism,” such work—that of J. S. Mill, Herbert Spencer, Hermann Lotze, and the early Alexander Bain, for example—simply does not give attention a significant role.²² According to George Herbert Mead, “associational psychology never explained why

20. Maine de Biran is also significant here for the way his work anticipates some later nineteenth-century notions about attention. In one sense, his notion of attention is clearly part of an earlier body of knowledge in which attention is merely one of a number of equally important and interrelated *faculties*, such as judgment, memory, perception, meditation. But Maine de Biran’s rethinking of the category of apperception opens up a new understanding of the very nature of *intuition* and leads him to a mobile and dynamic conception of the will, especially its embeddedness in motor activity, that has crucial affinities with some late nineteenth-century equations of attention and will. See, for example, Pierre Maine de Biran, *De l’apperception immédiate* (1807; Paris: J. Vrin, 1963). See also my discussion of Maine de Biran and the problematization of interiority in the early nineteenth century, in *Techniques of the Observer*, pp. 72–73.

21. Jan Goldstein, “Foucault and the Post-Revolutionary Self,” in Jan Goldstein, ed., *Foucault and the Writing of History* (Oxford: Blackwell, 1994), p. 102. See also Goldstein’s important related argument in her “The Advent of Psychological Modernism in France: An Alternative Narrative,” in Dorothy Ross, ed., *Modernist Impulses in the Human Sciences* (Baltimore: Johns Hopkins University Press, 1994), pp. 190–209.

22. The irrelevance of Bain, Mill, and associationism in general by the 1880s is signaled conclusively by James Ward’s article on “Psychology” in the ninth edition of the *Encyclopedia Britannica*, in which attention and volition figure as central categories. The place of attention in the thought of Thomas Reid, Dugald Stewart, and James Mill is differentiated from modern speculation and research in Charlton Bastian, “Les processus nerveux dans l’attention et la volition,” *Revue philosophique* 32 (April 1892), pp. 353–384.

one association rather than another was the dominant one.”²³ Not until the 1870s does one find attention consistently being attributed a central and formative role in accounts of how a practical or knowable world of objects comes into being for a perceiver. It would be difficult to find before 1850 an unconditional statement like Henry Maudsley’s from the early 1880s: “Whatever its nature, [attention] is plainly the essential condition of the formation and development of mind.”²⁴ I do not want to belabor this point or insist on some precise historical dividing line, but one telling piece of evidence is in the work of the enormously important physiologist William B. Carpenter, which held authoritative status not only in England but also in Europe and North America from the 1840s until well into the 1880s. In the 1853 edition of his standard textbook, attention is covered in a single paragraph and as merely one of many mental faculties such as observation, reflection, and introspection; by the 1874 edition, he devotes over fifty pages to the topic of attention, and references to it are scattered throughout many other sections of the book. Attention in 1853 was noted almost in passing as “that state in which the consciousness is actively directed to a sensorial change”; by 1874 attention has an effect “on each principal form of Mental activity” and is indispensable “for the systematic acquirement of Knowledge, for the control of the Passions and Emotions, and for the regulation of the Conduct.”²⁵ Moreover, only by the 1870s does it become, in Europe and North America, a problem that traverses a broad social and cultural field, an interrelated social, economic, psychological, and philosophical issue central to the most powerful accounts of the nature of human subjectivity. Edward Bradford Titchener, the British-born student of Wundt and one of the leading importers of German experimental psychology into America, asserted in the 1890s that “the problem of attention is essentially a modern problem,” although he was unable to grasp how the particular perceiving subject he was helping to delineate was to become a central component of institutional modernity.²⁶

23. Mead describes how “the psychology of attention ousted the psychology of association” in his *Mind, Self, and Society* (Chicago: University of Chicago Press, 1934), pp. 95–96.

24. Henry Maudsley, *The Physiology of Mind* (New York: D. Appleton, 1883), p. 310.

25. William B. Carpenter, *Principles of Human Physiology* (Philadelphia: Blanchard and Lea, 1853), p. 780; Carpenter, *Principles of Mental Physiology*, 4th ed. (1874; London: Kegan Paul, 1896), pp. 130–131. The later volume is a retitled expansion of the earlier. See the assessment of Carpenter’s historical significance in Edward S. Reed, *From Soul to Mind: The Emergence of Psychology from Erasmus Darwin to William James* (New Haven: Yale University Press, 1997), pp. 76–80. Also valuable is the discussion of Carpenter in Alison Winter, *Mesmerized: Powers of Mind in Victorian England* (Chicago: University of Chicago Press, 1998), pp. 287–305.

26. Edward Bradford Titchener, *Experimental Psychology: A Manual of Laboratory Practice*, vol. 1 (New York: Macmillan, 1901), p. 186. Elsewhere Titchener affirms that late nineteenth-century

By the last quarter of the nineteenth century, the specifically modern problem of attention is identifiable in many places.²⁷ In a wide range of institutional discourses and practices within the arts and human sciences, attention became part of a dense network of texts and techniques around which the truth of perception was organized and structured.²⁸ It was through the new imperatives of atten-

“experimental psychology discovered attention” and recognized “its separate status and fundamental importance; the realization that the doctrine of attention is the nerve of the whole psychological system.” Titchener, *Lectures on the Elementary Psychology of Feeling and Attention* (New York: Macmillan, 1908), p. 171.

27. A few of the very large number of works that treat this subject during this period are William James, *The Principles of Psychology*, vol. 1 (1890; New York: Dover, 1950), pp. 402–458; Theodule Ribot, *La psychologie de l'attention* (Paris: F. Alcan, 1889); Wilhelm Wundt, *Grundzuge der physiologischen Psychologie*, vol. 2 (1874; Leipzig: Englemann, 1880), pp. 205–213; Titchener, *Experimental Psychology*, pp. 186–328; Maudsley, *The Physiology of Mind*, pp. 310–324; Kulpe, *Outlines of Psychology*, pp. 423–454; Carl Stumpf, *Tonpsychologie*, vol. 2 (Leipzig: S. Hirzel, 1890), pp. 276–317; F. H. Bradley, “Is There Any Special Activity of Attention?,” *Mind* 11 (1886), pp. 305–323; Angelo Mosso, *Fatigue* (1891), trans. Margaret Drummond (New York: G. P. Putnam), pp. 177–208; Lemon Uhl, *Attention* (Baltimore: Johns Hopkins Press, 1890); Ladd, *Elements of Physiological Psychology*, pp. 480–497, 537–547; Eduard von Hartmann, *Philosophy of the Unconscious* (1868), trans. William C. Coupland (New York: Harcourt Brace, 1931), pp. 105–108; Hall, “Reaction Time and Attention in the Hypnotic State”; Georg Elias Muller, *Zur Theorie der sinnlichen Aufmerksamkeit* (Leipzig: A. Edelmann, 1873); James Sully, “The Psycho-Physical Processes in Attention,” *Brain* 13 (1890), pp. 145–164; John Dewey, *Psychology* (New York: Harper, 1886), pp. 132–155; Hermann Ebbinghaus, *Grundzuge der Psychologie*, vol. 1 (Leipzig: Veit, 1905), pp. 601–633; Henri Bergson, *Matter and Memory* (1896), trans. W. S. Palmer and N. M. Paul (New York: Zone Books, 1988), pp. 98–107; Theodor Lipps, *Grundtatsachen des Seelenlebens* (Bonn: M. Cohen, 1883), pp. 128–139; Leon Marillier, “Remarques sur le mecanisme de l'attention,” *Revue philosophique* 27 (1889), pp. 566–587; Bastian, “Les processus nerveux dans l'attention et la volition”; James McKeen Cattell, “Mental Tests and Their Measurement,” *Mind* 15 (1890), pp. 373–380; Josef Clemens Kreibitz, *Die Aufmerksamkeit als Willenserscheinung* (Vienna: Alfred Holder, 1897); Walter B. Pillsbury, *Attention* (1906; London: Sonnenschein, 1908); J. W. Slaughter, “The Fluctuations of Attention in Some of Their Psychological Relations,” *American Journal of Psychology* 12, no. 3 (1901), pp. 314–334; Sante De Sanctis, *L'attenzione e i suoi disturbi* (Rome: Tip. dell'Unione Coop. Edit., 1896); Heinrich Obersteiner, “Experimental Researches on Attention,” *Brain* 1 (1879), pp. 439–453; Pierre Janet, “Etude sur un cas d'oubolie et d'idees fixes,” *Revue philosophique* 31 (1891), pp. 258–287, 382–407; Theodor B. Hyslop, *Mental Psychology Especially in Its Relations to Mental Disorders* (London: Churchill, 1895), pp. 291–304; William B. Carpenter, *Principles of Mental Physiology* (1874; New York: D. Appleton, 1886), pp. 130–147; Giuseppe Sergi, *La psychologie physiologique* (1885, Italian; Paris: F. Alcan, 1888), pp. 237–248; Theodor Ziehen, *Introduction to Physiological Psychology*, trans. C. C. van Liew (London: Sonnenschein, 1892), pp. 206–214; Cappie, “Some Points in the Physiology of Attention, Belief and Will”; James R. Angell and Addison W. Moore, “Reaction Time: A Study in Attention and Habit,” *Psychological Review* 3 (1896), pp. 245–258; Alfons Pilzecker, *Die Lehre von sinnlicher Aufmerksamkeit* (Munich: Akademische Buchdruckerei von F. Straub, 1889); Andre Lalande, “Sur un effet particulier de l'attention appliquee aux images,” *Revue philosophique* 35 (March 1893), pp. 284–287; John Grier Hibben, “Sensory Stimulation by Attention,” *Psychological Review* 2, no. 4 (July 1895), pp. 369–375; Jean-Paul Nayrac, *Physiologie et psychologie de l'attention* (Paris: F. Alcan, 1906); Charles Sanders Peirce, “Some Consequences of Four Incapacities” (1868), in *Charles S. Peirce: Selected Writings*, ed. Philip P. Wiener (New York: Dover, 1958), pp. 39–72. Sigmund Freud, “Project for a Scientific Psychology,” in *The Origins of Psycho-analysis*, trans. Eric Mosbacher and James Strachey (New York: Basic Books, 1954), pp. 415–445; and Edmund Husserl, *Logical Investigations*, vol. 1 (1899–1900), trans. J. N. Findlay (New York: Humanities Press, 1970), pp. 374–386.

28. As I've already stated, I am using the word *perception* to indicate vision, hearing, touch, or an amalgam of several senses. Some recent studies on the importance of the auditory within problematizations of modernity include Douglas Kahn, “Introduction: Histories of Sound Once Removed,” in Dou-

tiveness that the perceiving body was deployed and made productive and orderly, whether as student, worker, or consumer. Beginning in the 1870s, there was an explosion of research and debate on this topic. It was a major issue in the influential work of Gustav Fechner, Wilhelm Wundt, Titchener, Theodor Lipps, Carl Stumpf, Oswald Kulpe, Ernst Mach, William James, and many others who interrogated the empirical and epistemological status of attentiveness. Also, the pathology of a supposedly normative attentiveness was an important part of the inaugural work in France of researchers like J.-M. Charcot, Alfred Binet, and Théodule Ribot. In the 1890s attention became a major issue for Freud, and was one of the problems at the heart of his abandonment of the “Project for a Scientific Psychology” and his move to new psychological models. This book is not concerned with whether or not there is some empirically identifiable mental or neurological capacity for attention. It is an object for me only in terms of this massive accumulation of *statements* and concrete social *practices* during a specific historical period that presumed the existence and importance of such a capacity. I use the term *attention* not to hypostatize it as a substantive object, but to refer to the field of those statements and practices and to a network of effects which they produced.²⁹ On one hand, then, I am asserting the centrality of attentiveness as a scientific object and social problem, but on the other I am emphasizing that the 1880s and 1890s generated a sprawling diversity of often contradictory attempts to explain it.³⁰ Over the next part of this chapter I will indicate some of the important elements and

las Kahn and Gregory Whitehead, eds., *Wireless Imagination: Sound, Radio and the Avant-Garde* (Cambridge: MIT Press, 1992), pp. 1–29; Steven Connor, “The Modern Auditory I,” in Roy Porter, ed., *Rewriting the Self: Histories from the Renaissance to the Present* (London: Routledge, 1997), pp. 203–223; and Michel Chion, *Audio-Vision: Sound on Screen*, trans. Claudia Gorbman (New York: Columbia University Press, 1994). Still valuable is the historicization of sound in Walter J. Ong, *The Presence of the Word* (New Haven: Yale University Press, 1967), pp. 111–191. See also the remarks on the importance of auditory attentiveness in Jean Laplanche and J.-B. Pontalis, “Fantasy and the Origins of Sexuality,” *International Journal of Psychoanalysis* 49 (1968), p. 10: “Hearing, when it occurs, breaks the continuity of an undifferentiated perceptual field and at the same time is a sign (the noise waited for and heard in the night) which puts the subject in the position of having to answer to something. To this extent the prototype of the signifier lies in the aural sphere, even if there are correspondences in the other perceptual registers.”

29. The archive of statements about attention in the nineteenth century can also be positioned as *metaphorical* attempts to account for a range of empirical phenomenon. See Jerome Bruner and Carol Feldman, “Metaphors of Consciousness and Cognition in the History of Psychology,” in David E. Leary, ed., *Metaphors in the History of Psychology* (Cambridge: Cambridge University Press, 1990), pp. 230–238.

30. Obviously, many of the thinkers for whom attention was an issue represent dissimilar or even completely irreconcilable intellectual and philosophical positions, such as Wundt and Mach, Dilthey and Ebbinghaus, Freud and Janet, Delboeuf and Binet, Helmholtz and Hering, and so on. Even several decades into the twentieth century, there was a general awareness of the absence of a convincing empirical account of this problem. Exemplary would be George Herbert Mead’s conclusion, “The physiology of attention is still a dark continent,” in *Mind, Self, and Society*, p. 25.

consequences of these finally unsuccessful attempts. However, I am not suggesting that there was any single or dominant model of an attentive observer. Attention was not part of a particular regime of power but rather part of a space in which new conditions of subjectivity were articulated, and thus a space in which effects of power operated and circulated. That is to say, new constructions of attentiveness occurred amid larger refigurations of subjectivity in the nineteenth century, and, as we have learned from studies of madness and sexuality in the same period, it was always a question of shifting relations between discursive/institutional power on one hand and a composite of forces that inherently resisted stabilization and control on the other.

Since the study of attention in this period attempted, as I will show, to rationalize what it ultimately revealed to be unrationalizable, the questions it asked are finally more important than its empirical conclusions. Some of the most pervasive of these questions were the following: How did attention screen out some sensations and not others? What determined how attention operated as a narrowing and focusing of conscious awareness? What forces or conditions caused an individual to attend to some limited aspects of an external world and not others? How many events or objects could one attend to simultaneously and for how long (i.e., what were its quantitative and physiological limits)? To what extent was attention an automatic or voluntary act; to what extent did it involve motor effort or psychic energy? For most authors, attention implied some process of perceptual or mental organization in which a limited number of objects or stimuli are isolated from a larger background of possible attractions. John Dewey provides an exemplary account, using optical figures, in his 1886 textbook: “In attention we focus the mind, as the lens takes all the light coming to it, and instead of allowing it to distribute itself evenly concentrates it in a point of great light and heat. So the mind, instead of diffusing consciousness over all the elements presented to it, brings it all to bear upon some one selected point, which stands out with unusual brilliancy and distinctness.”³¹ But however it was described—organization, selection, isolation—attention implied an inevitable fragmentation of a visual field in which the unified and homogeneous coherence of classical models of vision was impossible. The camera obscura model of vision in the eighteenth century described an ideal relation of self-presence between observer and world. Attention as a process of selection necessarily meant that perception was an activity of *exclusion*, of rendering

31. Dewey, *Psychology*, p. 134.

parts of a perceptual field unperceived.³² The cultural and philosophical implications of this reconceptualization in turn raised a larger set of problems and produced a range of positions, which I will group into three loose categories. There were those who posed attention as an expression of the conscious will of an autonomous subject for whom the very activity of attention, as choice, was part of that subject's self-constituting freedom. There were those who believed that attention was primarily a function of biologically determined instincts, unconscious drives, a remnant, as Freud and others believed, of our archaic evolutionary heritage, which inexorably shaped our lived relation to an environment.³³ And there were those who believed that an attentive subject could be produced and managed through the knowledge and control of external procedures of stimulation as well as a wide-ranging technology of "attraction."³⁴

For attention is not just one of the many topics examined experimentally by late nineteenth-century psychology but is the fundamental condition of its knowledge.³⁵ Most areas of research—reaction times, sensory and perceptual sensitivity, mental chronometry, reflex action, conditioned responses—all presupposed a

32. Hegel's understanding of attention as "the beginning of education," as one of the means by which we obtain "knowledge of subject matter," is clearly part of an older set of models. However, his intuition of the division and loss of subjectivity in attention sets up the terms of a distinctly modern conceptualization, which turns on the problem of selectivity and exclusion: "But it does not follow that attention is an easy matter. On the contrary, it demands an effort since a man, if he wants to apprehend one particular object, must make abstraction from everything else, from all the thousand and one things going round in his head, from his other interests, even from his own person; he must suppress his own conceit which would rashly judge the subject-matter before it had a chance to speak for itself, must stubbornly absorb himself in the subject-matter, must fix his attention on it and let it have *its* say without obtruding his own reflections. Attention contains, therefore, the negation of one's self-assertion and also the surrender of oneself to the matter in hand." *Hegel's Philosophy of Mind*, trans. William Wallace and A. V. Miller (Oxford: Oxford University Press, 1971), pp. 195–196.

33. Freud, *Origins of Psycho-analysis*, p. 417.

34. The work of Tom Gunning has been important for demonstrating that one of the formative components of a modernized mass visual culture in the West, as it took shape in the late 1880s and 1890s, was a technology of "attraction." Discussing early cinema, Gunning demonstrates that what was at stake was not primarily representation, imitation, narration, or the updating of theatrical forms. Rather it was a strategy of engaging an attentive spectator: "From comedians smirking at the camera, to the constant bowing and gesturing of conjurers in magic films, this is a cinema that displays its visibility, willing to rupture a self-enclosed fictional world for a chance to solicit the attention of the spectator." Gunning, "The Cinema of Attractions: Early Film, Its Spectator, and the Avant-Garde," in Thomas Elsaesser, ed., *Early Cinema: Space, Frame, Narrative* (London: BFI, 1990), p. 57.

35. On the particular status of psychology in the nineteenth century and its special relation to philosophy see Katherine Arens, *Structures of Knowing: Psychologies of the Nineteenth Century* (Dordrecht: Kluwer, 1989); Elmar Holenstein, "Die Psychologie als eine Tochter von Philosophie und Physiologie," in Ernst Florey and Olaf Breidbach, eds., *Das Gehirn, Organ der Seele? Zur Ideengeschichte der Neurobiologie* (Berlin: Akademie Verlag, 1993), pp. 289–308; David E. Leary, "The Philosophical Development of the Conception of Psychology in Germany," *Journal of the History of the Behavioral Sciences* 14 (1978), pp. 113–121.

subject whose attentiveness was the site of observation, classification, and measurement, and thus the point around which knowledge of many kinds was accumulated. Fechner's attempts in the 1850s to quantify subjective experience by measuring external stimulation is one of the early instances of this emerging model of attention. Fechner's famous unit of measurement, "a just noticeable difference" (or JND), was possible only through an experimental practice in which a test subject was required to be attentive to various magnitudes of sensory stimulation, and to judge at what level differences between stimuli were perceptible.³⁶ But, as William James and others realized, Fechner's work also implied the volatile and non-homogeneous makeup of perception in his notion of the stimulus "threshold." Even as his work opened the vast rationalizing possibilities of psychometrics, at the same time it disclosed the qualitative discontinuities that irrevocably fragmented the apparently uniform fabric of perceptual experience (such as the liminal shifts from consciousness of a sensation to unconsciousness or insensibility, or from sensation of pleasure, via an increase in pleasurable stimuli, into sensation of pain).³⁷ Even as attention is the site of quantification for Fechner, it simultaneously suggested subjective operations of repression and anesthetization, which were to be of considerable importance for Freud and others.³⁸

The model of an attentive human observer that dominated the empirical sciences from the 1880s on was also inseparable from a radically transformed notion of what constitutes sensation for a human subject.³⁹ Within the increasingly sophisticated laboratory environment, sensation became an effect or set of effects that

36. Fechner explicitly acknowledged the intrinsic unreliability of subjective testimony and the variability of attentiveness itself, but through what he called "the method of average error" he made the undependability of human subjects fully compatible with statistical computations based on very large amounts of data.

37. "If even the slightest stimulus were effective, we would have to feel an infinite mixture and unending variety of mild sensations of every kind at all times, since minimal stimuli of all types constantly surround us. Such is not the case. The fact that each stimulus must first reach a certain limit before it arouses a sensation assures to mankind a state undisturbed to a certain degree by external stimulation. . . . Besides the fact that we are saved from disturbances by unwanted and strange perceptions, because any stimulus escapes notice when it falls below a certain point, there is also the fact that a uniform state of perception is assured because stimulus differences cannot be noticed below their threshold." Gustav Fechner, *Elements of Psychophysics*, trans. Helmut Adler (New York: Holt, Rinehart, 1966), p. 208. See the remarks on Fechner's cultural importance in Dolf Sternberger, *Panorama of the Nineteenth Century*, trans. Joachim Neugroschel (New York: Urizen, 1977), pp. 211–212.

38. See, for example, Sigmund Freud, *Beyond the Pleasure Principle*, trans. James Strachey (New York: Norton, 1961), pp. 2–4.

39. See the rich discussion of the scientific and philosophical problems raised by late nineteenth-century models of sensation in Emile Meyerson, *Identity and Reality* (1908), trans. Kate Loewenberg (New York: Dover, 1962), pp. 291–307.

were technologically produced and were used to describe a subject who was compatible with those technical conditions. That is, its significance as an “interior” faculty disappeared and it became a quantity or set of effects that could be measured or observed externally. In particular, attention was studied in terms of response to machine-produced stimuli, often electrical in nature and abstract in content, that allowed a quantitative determination of the sensory capacities of a perceiving subject.⁴⁰ Within this vast project, an older model of sensation as something *belonging* to a subject became irrelevant. Sensation now had empirical significance only in terms of magnitudes that corresponded to specific quantities of energy (e.g., light) on one hand and to measurable reaction times and other forms of performative behavior on the other. It cannot be emphasized too strongly how, by the 1880s, the classical idea of sensation ceases to be a significant component in the cognitive picture of nature.⁴¹

But just as the rise of psychometry (i.e., any attempt at quantification or measurement of mental processes) in the human sciences either diminished or altered the importance of subjective sensation, another challenge to the classical notion of sensation can be seen in the work of a wide range of thinkers, in James, Nietzsche, Bergson, and Charles S. Peirce but also, as I will argue, in the work of Seurat and Cezanne. James and Bergson, in particular, explicitly challenged the notion of a pure or simple sensation, on which associationism depended. Both contended that any sensation, no matter how seemingly elemental, is always a compounding of memory, desire, will, anticipation, and immediate experience.⁴² But at the same time their work offered little support for the idea of a “pure” or autonomous aesthetic perception. Peirce, too, argued against the idea of “immediate” sensations, asserting that they are irreducible complexes of association and interpretation.⁴³

40. On the technological transformation of physiology and psychology in the nineteenth century, see Timothy Lenoir, “Models and Instruments in the Development of Electrophysiology, 1845–1912,” *Historical Studies in the Physical and Biological Sciences* 17, pt. 1 (1986), pp. 1–54. See the suggestive remarks on the possibility of a cultural history of electricity “that would address the specific ways in which it has shaped subjectivity,” in Felicia McCarren, “The ‘Symptomatic Act’ circa 1900: Hysteria, Hypnosis, Electricity, Dance,” *Critical Inquiry* 21 (Summer 1995), p. 763.

41. See the important historical problematization of “mechanical objectivity” in the nineteenth century and the related orientation of the observer “beyond the limits of the human senses” in Lorraine Daston and Peter Galison, “The Image of Objectivity,” *Representations* 40 (Fall 1992), pp. 81–128.

42. James was, however, convinced that “pure sensations” could be realized in the first days of life by an infant. *Principles of Psychology*, vol. 2, p. 7. He coined one of his most memorable phrases when he described how the “one great blooming, buzzing confusion” of the newborn baby quickly “coalesces” into a unified and homogeneous intuition of space. *Principles of Psychology*, vol. 1, p. 488.

43. Peirce, “Some Consequences of Four Incapacities,” pp. 56–62.

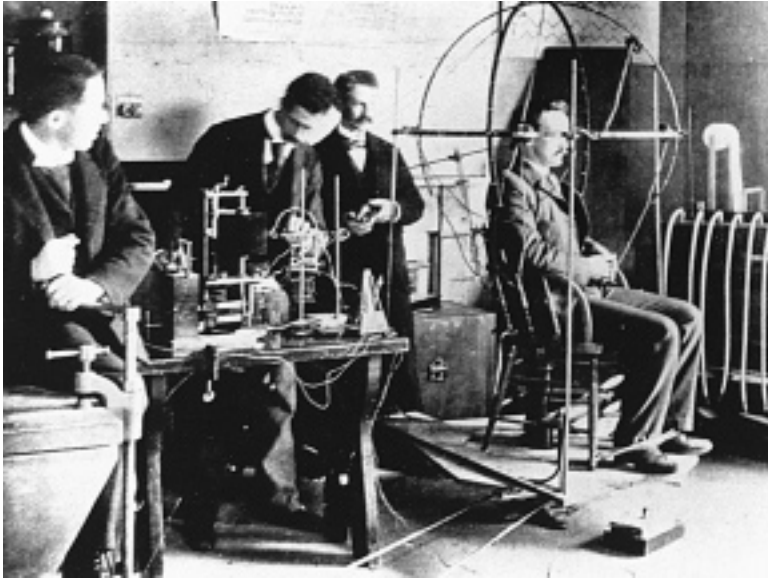

Experiment on attentiveness to sound location, 1893.

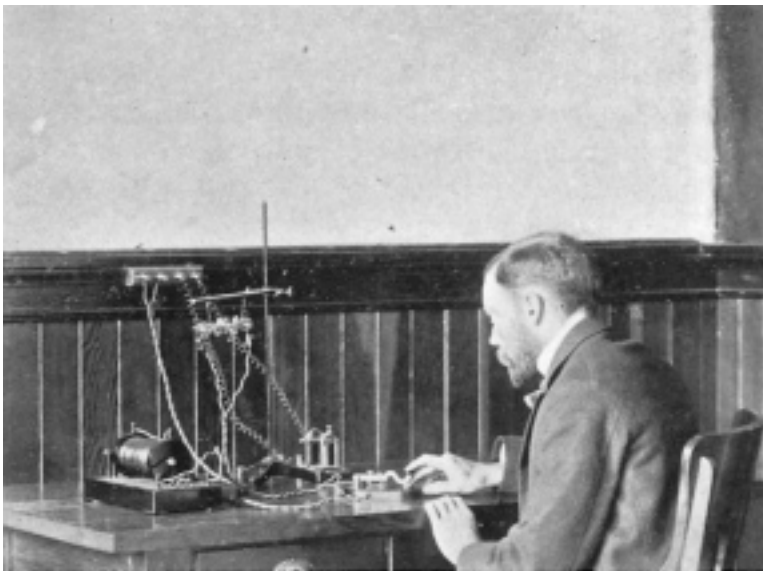

Measurement of attention to electrical sparks, 1890s. Photograph shows conditions of experiment conducted in darkness.

Ernst Mach continued to employ the word “sensations” but refashioned it to indicate psychic “elements” that could not provide knowledge of a “true” external world.⁴⁴ Important within this reorganization of perceptual experience, the contours of which I have only hinted at, was a struggle over how sensation and stimuli were interpreted, attended to, and made useful.

The problem of attention, then, was not a question of a neutral timeless activity like breathing or sleeping but of the emergence of a specific model of behavior with a historical structure—behavior that was articulated in terms of socially determined norms and was part of the formation of a modern technological milieu. Anyone familiar with the history of modern psychology knows the symbolic importance of the date 1879, the year when Wilhelm Wundt established the world’s first psychology laboratory at the University of Leipzig.⁴⁵ Irrespective of the specific nature of Wundt’s intellectual project, this laboratory space, with its newly codified research procedures and finely calibrated apparatuses, became the model for the whole modern social organization of psychological experimentation around the study of an observer attentive to a wide range of artificially produced stimuli.⁴⁶ To paraphrase Foucault, this has been one of the practical and discursive spaces within modernity in which human beings “problematize what they are.”⁴⁷

This problem was elaborated within an emergent economic system that demanded attentiveness of a subject in a wide range of new productive and spectacular tasks, but whose internal movement was continually eroding the basis of any disciplinary attentiveness. Part of the cultural logic of capitalism demands that we

44. See the discussion of Mach’s reconceptualization of scientific objectivity and parallel disintegration of the subject in Theodore Porter, “The Death of the Object: Fin-de-Siecle Philosophy of Physics,” in Ross, ed., *Modernist Impulses in the Human Sciences 1870–1930*, pp. 128–151.

45. On Wundt and the beginnings of the psychology laboratory see Kurt Danziger, *Constructing the Subject: Historical Origins of Psychological Research* (Cambridge: Cambridge University Press, 1990), pp. 17–33. See also Didier Deleule, “The Living Machine: Psychology as Organology,” in Jonathan Crary and Sanford Kwinter, eds., *Incorporations* (New York: Zone Books, 1992), pp. 203–233. Occasionally, the priority of Wundt’s laboratory is challenged in favor of the “laboratory” assembled by William James in Laurence Hall at Harvard in 1875, where he performed demonstrations for his students but did not then conduct or initiate any sustained experimental research program.

46. Studies on attention, like almost all important work within experimental psychology in the late nineteenth century, obviously involved human test subjects with specific demographic and sociological features such as age, gender, social class. It is well known, for example, that in the first ten years of the operation of Wundt’s Leipzig laboratory his subjects were almost exclusively his own male students. Much the same was true of James McKeen Cattell’s work at Columbia University in the 1890s. See the valuable discussion in Kurt Danziger, “A Question of Identity: Who Participated in Psychological Experiments,” in Jill G. Morawski, ed., *The Rise of Experimentation in American Psychology* (New Haven: Yale University Press, 1988), pp. 35–52.

47. Michel Foucault, *The Use of Pleasure*, trans. Robert Hurley (New York: Random House, 1985), p. 10.

accept as *natural* switching our attention rapidly from one thing to another.⁴⁸ Capital, as accelerated exchange and circulation, necessarily produced this kind of human perceptual adaptability and became a regime of reciprocal attentiveness and distraction. Helmholtz's account of subjective vision in his *Physiological Optics* established the truth of an observer in terms of an innate compatibility with this organization of experience: "It is natural for the attention to be distracted from one thing to another. As soon as the interest in one object has been exhausted, and there is no longer anything new in it to be perceived, it is transferred to something else, even against our will. When we wish to rivet it on an object, we must constantly seek to find something novel about it, and this is especially true when other powerful impressions of the senses are tugging at it and trying to distract it."⁴⁹ Unlike in any previous order of visibility, mobility, novelty, and distraction became identified as constituent elements of perceptual experience.⁵⁰ Even some of the most avid defenders of technological progress acknowledged that subjective adaptation to new perceptual speeds and sensory overload would not be without difficulties. Nordau predicted that "the end of the twentieth century, therefore, will probably see a generation to whom it will not be injurious to read a dozen square yards of newspapers daily, to be constantly called to the telephone, to be thinking simultaneously of the five continents of the world, to live half their time in a railway carriage or in a flying machine and . . . know how to find its ease in the midst of a city inhabited by millions."⁵¹ What he and others failed to grasp then was that modernization was not a one-time set of changes but an ongoing and perpetually modulating process that would never pause for individual subjectivity to accommodate and "catch up" with it.

Obviously, as I've suggested, in the late nineteenth century attention became a problem alongside the specific systemic organization of labor and production by industrial capitalism. But even as the global functioning of capitalism has mutated

48. See the related discussion in Fredric Jameson and Anders Stephanson, "Regarding Postmodernism: A Conversation with Fredric Jameson," in Douglas Kellner, ed., *Postmodernism, Jameson, Critique* (Washington, D.C.: Maisonneuve Press, 1989), pp. 43–74, esp. p. 46.

49. Hermann von Helmholtz, *Treatise on Physiological Optics*, vol. 3, ed. James P. C. Southall (New York: Dover, 1962), p. 498.

50. Photography, whose development coincides historically with the acceleration of nineteenth-century capitalism, was intertwined with the emergence of new rhythms of attentive receptiveness. For example, Victor Burgin, insisting on the fundamental difference between how photographs and painting are observed, discusses "the awkwardness which accompanies the over-long contemplation of a photograph" in his "Looking at Photographs," in Victor Burgin, ed., *Thinking Photography* (London: Macmillan, 1982), pp. 142–153.

51. Nordau, *Degeneration*, p. 541.

in the course of the twentieth century into postindustrial and information/communication-based phases, attention as a subjective and social problem retains some enduring features. To make this more concrete, consider one of the places where an influential model of an attentive subject was constructed, and where some elements of a modern system of perceptual transformation and adaptability were formulated: the work of Thomas Edison. Edison is a prominent sign of the transition to centralized corporate capitalism in the late nineteenth century (even though some aspects of his enterprise retained preindustrial practices and others pointed toward features of an information/communications-based economy). It is within this shift that we can locate his move away from earlier nineteenth-century techniques of display, exhibition, and consumption to paradigms that would become dominant in the twentieth century. Edison's importance lies not with any particular device or invention but rather in his role in the emergence, beginning in the 1870s, of a new system of quantification and distribution.⁵² Raymond Williams locates the origins of this system later, in radio and television, but his analysis is applicable to much of Edison's production: a system "primarily designed for transmission and reception as abstract processes, with little or no definition of preceding content."⁵³ For Edison, cinema, for example, had no significance in itself—it was simply one of a potentially endless stream of ways in which a space of consumption and circulation could be dynamized, activated.⁵⁴ Edison saw the marketplace in terms of how images, sounds, energy, or information could be reshaped into measurable and distributable commodities and how a social field of individual subjects could be arranged into increasingly separate and specialized units of consumption.⁵⁵ The logic that supported the Kinetoscope and the

52. See the important discussion of Edison in Thomas P. Hughes, *Networks of Power: Electrification in Western Society 1880–1930* (Baltimore: Johns Hopkins University Press, 1983), 18–78. "Edison was a holistic conceptualizer and determined solver of the problems associated with the growth of systems" (p. 18).

53. Raymond Williams, *Television: Technology and Cultural Form* (New York: Schocken, 1975), p. 25.

54. For a valuable genealogical account in which the prehistory of cinema and television overlap beginning in the 1850s, see Siegfried Zielinski, *Audiovisionen: Kino und Fernsehen als Zwischenspiele in der Geschichte* (Reinbek bei Hamburg: Rowohlt, 1989), pp. 19–93.

55. Other pivotal nineteenth-century figures should be mentioned here. Werner von Siemens certainly precedes Edison as the conceptualizer of a new economic and social space based on the quantification and distribution of energy. Also relevant is Lord Kelvin, who was a central participant in the globalization of telegraphic communication and subsequently in the commodification and marketing of electric power in England. See Crosbie Smith and M. Norton Wise, *Energy and Empire: A Biographical Study of Lord Kelvin* (Cambridge: Cambridge University Press, 1989), 649–722. The uniqueness of Edison's enterprise, however, is the way in which the components of an emerging mass culture (film, photography, recorded sound) were understood as part of the same abstract territory on which units of energy indifferently circulated.



Edison's stock ticker apparatus, 1869.

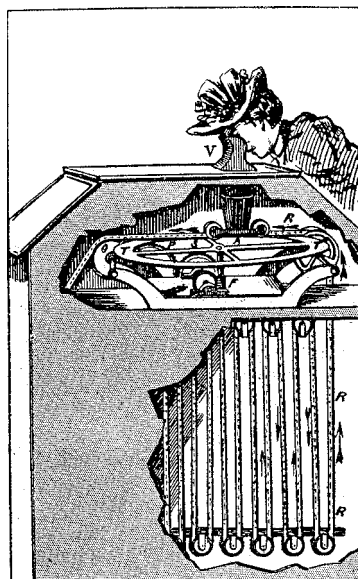

*Edison's Kinetoscope, 1893.
Cutaway view showing 45-foot
loop of film and display
mechanism.*

phonograph—that is, the structuring of perceptual experience in terms of a solitary rather than a collective subject—is replayed today in the increasing centrality of the computer screen as the primary vehicle for the distribution and consumption of electronic entertainment commodities.

At the same time, Edison's early understanding of the economic relation between hardware and software (the machines to make movies, the machines with which to view movies, and the movies themselves) coincided with emerging (and enduring) patterns of vertical integration of these spheres of production within a single corporation.⁵⁶ Edison's first technological product, a hybrid telegraph–stock ticker in the early 1870s, is paradigmatic for what it foreshadows in subsequent technological arrangements, including those of the late twentieth century: the in-

56. Edison's work is discussed in terms of both its origins in preindustrial machine-shop craft practices and its central position within a "second industrial revolution" lasting from the 1870s to World War I, in Andre Millard, *Edison and the Business of Invention* (Baltimore: Johns Hopkins University Press, 1990). On the historical emergence of models of vertical integration in the 1880s, see Giovanni Arrighi, *The Long Twentieth Century: Money, Power and the Origins of Our Times* (New York: Verso, 1994), pp. 285–289.

distinction between information and visual images, and the making of quantifiable and abstract flow into the object of attentive consumption.⁵⁷ Edison's grasp of some of the systemic features of capitalism as it evolved in the 1880s and 1890s underscores the abstract nature of the products he "invented"; his work was inseparable from the continual manufacture of new needs and the consequent restructuring of the network of relations in which such products would be consumed.⁵⁸ Recent corporate innovators Stephen Jobs, Bill Gates, and Andrew Grove are later participants in this same historical project of perpetual rationalization and modernization. In the late twentieth century as in the late nineteenth, the management of attention depends on the capacity of an observer to adjust to continual reappearings of the ways in which a sensory world can be consumed. Throughout changing modes of production, attention has continued to be a disciplinary immobilization as well as an accommodation of the subject to change and novelty—as long as the consumption of novelty is subsumed within repetitive forms.

Since the late 1800s, the problem of attention has remained more or less within the center of institutional empirical research and at the heart of the functioning of a capitalist consumer economy.⁵⁹ It could be argued rather strictly that during the hegemony of behaviorism, beginning in the early twentieth century and

57. Neil Postman singles out the earlier invention of the telegraph in the 1840s as a precedent for these developments in its creation of "a world of anonymous, decontextualized information. The telegraph also moved history into the background and amplified the instant and simultaneous present." That the emergence of this perpetual "present" entailed a reorganization of the perceiving subject along the lines of my argument is symbolically signaled by what some authorities insist was Samuel F. B. Morse's actual first transmission: "Attention Universe." See Neil Postman, *The Disappearance of Childhood* (New York: Delacorte Press, 1982), pp. 68–72.

58. For a more extended discussion of this legacy of Edison's work in the twentieth century, see my "Dr. Mabuse and Mr. Edison," in Kerry Brougher, ed., *Art and Film since 1945: Hall of Mirrors* (New York: Monacelli Press, 1996), pp. 262–279. For a few recent detailed accounts of the practical subjective adaptation necessitated by accelerated technological innovation, see Edward Tenner, *Why Things Bite Back: Technology and the Revenge of Unintended Consequences* (New York: Knopf, 1996), pp. 161–209; Gene I. Rochlin, *Trapped in the Net: The Unanticipated Consequences of Computerization* (Princeton: Princeton University Press, 1997), pp. 29–32; and David Shenk, *Data Smog: Surviving the Information Glut* (New York: Harper Collins, 1997), pp. 35–50.

59. Throughout the twentieth century various positions in philosophy and psychology have rejected it as a relevant or even meaningful problem. See, for example, the devaluation of attention as a problem in Maurice Merleau-Ponty, *The Phenomenology of Perception*, trans. Colin Smith (New York: Routledge, 1962), pp. 26–31. Many studies since the mid-twentieth century have worked with notions of cognitive processing and channel capacity borrowed from information theory. One influential midcentury account of attention was Donald Broadbent's "filter theory" in his *Perception and Communication* (New York: Pergamon, 1958). For a survey of recent work, see Harold E. Pashler, *The Psychology of Attention* (Cambridge: MIT Press, 1998), and the research positions represented in Raja Parasuraman and D. R. Davies, eds., *Varieties of Attention* (Orlando: Academic Press, 1984). See also Julian Hochberg, "Attention, Organization and Consciousness," in D. I. Mostofsky, ed., *Attention: Contemporary Theory and Analysis* (New York: Appleton Century Crofts, 1970); Alan Allport, "Visual Attention," in Michael Posner, ed., *Foundations of Cognitive Science* (Cambridge: MIT Press, 1989), pp. 631–682; A. H. C. Van der

especially in the 1920s and 1930s, attention, along with the idea of a “mental process,” was proscribed or marginalized as an explicit object of research. But in fact, regardless of terminological polemics, the entire regime of stimulus-response research was founded on the attentive capacities of a human (or even animal) subject. It has been argued that problems related to the efficient human use of new technology during World War II were in part responsible for a new wave of research into attention: there were issues of “vigilance” in, for example, the continuous scanning of radar screens by human operators.⁶⁰ During the last few decades, within the context of a dramatically transformed space of knowledge and neurological research, it is not uncommon to encounter claims, such as those of Popper and Eccles, that the unitary character of the self-conscious mind is inseparable from attention.⁶¹ More recently, neurologist Antonio Damasio has maintained that “without basic attention and working memory there is no prospect of coherent mental activity.”⁶² Much contemporary study is founded on the assumption that attention is not simply a psychological issue but that its operation can be demonstrated on the neuronal level, while others believe it will always be a more elusive phenomenon.⁶³ Whatever the relative merits of various theories, attention has

Heijden, *Selective Attention in Vision* (London: Routledge, 1992); Gerald Edelman, *Bright Air, Brilliant Fire: On the Matter of Mind* (New York: Basic Books, 1992), pp. 137–144; Stephen M. Kosslyn, *Image and Brain: The Resolution of the Imagery Debate* (Cambridge: MIT Press, 1994), pp. 87–104; and Patricia Smith Churchland, *Neurophilosophy: Toward a Unified Science of the Mind-Brain* (Cambridge: MIT Press, 1986), pp. 474–478. A range of sociological and anthropological approaches is collected in Michael A. Chance and Roy R. Larsen, eds., *The Social Structure of Attention* (London: John Wiley and Sons, 1976).

60. See L. S. Hearnshaw, *The Shaping of Modern Psychology* (London: Routledge, 1987), pp. 206–209: “The term ‘vigilance’ was first employed by the neurologist Henry Head to describe the state of the nervous system conducive to speedy and adequate responses. It was adopted by Mackworth, the Cambridge psychologist, in his wartime studies of visual and auditory monitoring, and defined by him as ‘a state of readiness to detect and respond to certain specified small changes occurring at random time intervals in the environment.’”

61. Karl R. Popper and John C. Eccles, *The Self and Its Brain* (New York: Springer, 1977), pp. 361–362. The authors discuss how the selective activity of attention gives “unity to the most transient experiences.” They propose that the experienced coherence and “gestalt character” of consciousness comes, not from a neurophysiological synthesis, but from the integrating character of the self-conscious mind.

62. Antonio R. Damasio, *Descartes’ Error: Emotion, Reason and the Human Brain* (New York: Putnam, 1994), p. 197.

63. See, for example, Michael I. Posner and Stanislas Dehaene, “Attentional Networks,” *Trends in Neurosciences* 17, no. 2 (1994), p. 75: “The study of attention has been an important area of research since the inception of psychology in the late 1800s. However, it has remained controversial whether there are any separate brain mechanisms that subserves attention. Attention does not give rise to a unique qualitative experience like vision or touch, nor does it automatically produce motor responses. While we appear to be able to select sensory stimuli, information in memory, or motor responses, this might not indicate a separate attention system, since all brain systems play a role in selection.”

proven to be a remarkably persistent problem within the generalized disciplinary context of the social and behavioral sciences.⁶⁴

Over the last few years we have been reminded of the durability of attention as a normative category of institutional power, in the form of the dubious classification of an “attention deficit disorder” (or ADD) as a label for unmanageable schoolchildren and others. Without entering into the larger issue of the social construction of illness, what stands out is how attention continues to be posed as a normative and implicitly natural function whose impairment produces a range of symptoms and behaviors that variously disrupt social cohesion.⁶⁵ One recent study on ADD declares, “What is deficient is the control exerted over behavior by rules,” making explicit that the real concern is with rule-governed conduct.⁶⁶ As one reads the literature on ADD, one regularly reencounters some of the exact language and evaluations of Ribot and Nordau in the 1890s, especially in the enumeration of symptoms.⁶⁷ Thus, children with ADD are ones who “will not concentrate, won’t listen, refuse to pay attention, and won’t follow rules. . . . They can’t sit still, talk excessively and out of turn, fidget and throw non-sequiturs into conversation.”⁶⁸ Of course, one distinction that separates contemporary discussions from those of

64. A different approach to the problem of attention, remote from the historical concerns of this book, can be found in some areas of twentieth-century analytic philosophy, where distinctions are made between various concepts such as “noticing,” “interest,” “awareness,” and “mindfulness.” See, for example, the discussion of “heed concepts” in Gilbert Ryle, *The Concept of Mind* (London: Hutchinson, 1949), pp. 135–144. For Ryle, “heed” refers to “the concepts of noticing, taking care, attending, applying one’s mind, concentrating, putting one’s heart into something, thinking what one is doing, alertness, interest, intentness, studying and trying.” See also the general overview in A. R. White, *Attention* (Oxford: Blackwell, 1964).

65. By the late 1870s inattentiveness had been widely associated with a range of sociopathic forms of behavior, for example in Cesare Lombroso, *L’homme criminel: Etude anthropologique et medico-legale* (1876, Italian), trans. G. Regnier and A. Bournet (Paris; F. Alcan, 1887), pp. 424–426. One of the first comprehensive sociological accounts of attention is Theodule Ribot’s *Psychologie de l’attention* (1889) in which determinations of race, gender, nationality, and class were central to his evaluations. For Ribot, those characterized by deficient capacity for attention include “children, prostitutes, savages, vagabonds and South Americans.” This book was one of the sources for Max Nordau’s reflections on attention in *Degeneration* (1892). However, there were influential claims that attentive capacities were unrelated to gender, for example the widely cited work by the Viennese clinician Heinrich Obersteiner, “Experimental Researches on Attention,” *Brain* 1 (January 1879), pp. 439–453: “As regards sex, it may be stated that there does not appear to be any direct relation, in and by itself, between this and the degree or power of attention.”

66. R. Barkley, “Do as We Say, Not as We Do: The Problem of Stimulus Control and Rule-Governed Behavior in Attention Deficit Disorder with Hyperactivity,” in Lewis M. Bloomingdale and J. M. Swanson, eds., *Attention Deficit Disorder: New Directions in Attentional and Conduct Disorders* (New York: Elsevier, 1990), p. 24.

67. See, for example Carpenter’s case study of Coleridge’s “congenital weakness of the voluntary attention” in *Principles of Mental Physiology*, pp. 266–269.

68. Claudia Wallis, “Life in Overdrive,” *Time*, July 18, 1994, p. 49.

a century ago is the insistence that ADD is not linked to any weakness of the will, that there is no personal responsibility involved. Even after admitting that there is absolutely no experimental or empirical confirmation of an ADD diagnosis, the authors of a best-selling book on the subject make the claim: "Remember that what you have is a neurological condition. It is genetically transmitted. It is caused by biology, by how your brain is wired. It is *not* a disease of the will, nor a moral failing, nor some kind of neurosis. It is not caused by a weakness in character, or by a failing to mature. Its cure is not to be found in the power of the will, nor in punishment, nor in sacrifice, nor in pain. Always remember this. Try as they might, many people with ADD have great trouble accepting the syndrome as being rooted in biology rather than in weakness of character."⁶⁹ Other more prudent researchers admit the difficulty of establishing any consistent screening criteria for the condition, referring to it as a "rather elusive childhood disorder."⁷⁰

We learn from "experts" of our own time that this condition is characterized by "impulsiveness, short attention span, low frustration tolerance, distractibility, aggressiveness and in varying degrees, hyperactivity."⁷¹ The diagnosis of ADD in adults is increasingly linked to feelings of underachievement, in such a way that any sort of economic shortcoming or social insecurity is now understandable in terms of a failure to apply oneself attentively to the ideologically determined standards of performance and "achievement."⁷² In a culture that is so relentlessly founded on a short attention span, on the logic of the nonsequitur, on perceptual overload, on the generalized ethic of "getting ahead," and on the celebration of aggressiveness, it is nonsensical to pathologize these forms of behavior or look for the causes of this imaginary disorder in neurochemistry, brain anatomy, and genetic predisposition. Of course there are some ADD researchers who understand how the individual is caught between the subjective dislocations of modernization and imperatives for institutional discipline and productivity. That is, the behavior categorized as ADD is merely one of many manifestations resulting from this cul-

69. Edward M. Hallowell and John J. Ratey, *Driven to Distraction* (New York: Pantheon, 1994), p. 247.

70. Edward A. Kirby and Liam K. Grimley, *Understanding and Treating Attention Deficit Disorder* (New York: Elsevier, 1986), p. 5.

71. Melinda Blau, "A.D.D.: The Scariest Letters in the Alphabet," *New York Magazine*, December 13, 1993, pp. 45–51.

72. See, for example, Kevin R. Murphy and Suzanne Levert, *Out of the Fog: Treatment Options and Coping for Adult Attention Deficit Disorder* (New York: Hyperion, 1995), in which symptoms of ADD include poor management, communication, and organizational skills in the workplace. See the excellent cultural overview of ADD in Lawrence H. Diller, "Running on Ritalin," *Double Take* 14 (Fall 1998), pp. 46–55.

tural double bind, from the contradictory modes of performance and cognition that are continually demanded or incited. One writer quizzically notes this paradox: “Many, if not most, hyperactive children are apparently able to sustain attention for a substantial period of time in high interest situations, such as watching television shows or playing video games.”⁷³

Clearly, many of the systemic measures in place now for the efficient management of attention are working imperfectly at best. Many of the modes of fixation, of sedentarization, of enforced attentiveness implicit in the diffusion of the personal computer may have achieved some of its disciplinary goals, in the production of what Foucault calls docile bodies. The proliferation of electronic and communication products insures that docility will always be linked with intensified patterns of consumption, but the forms of social disintegration that have accompanied this new regime have generated behaviors (e.g., children who will not learn) that have become systemically intolerable. And, as the institutional discourse on attention indicates, we are now seeing the dramatic expansion of another layer of disciplinary technology—the sweeping use of potent neurochemicals as a strategy of behavior management. At the same time, the modern cultural problem of attentiveness has, as one of its outer limits, the volatile and uncertain phenomenon of schizophrenia.⁷⁴ One dominant model of schizophrenic experience for much of the twentieth century has been that of a perceiving subject with a reduced or damaged capacity for selective attentiveness. That is, the schizophrenic is attentive to an overwhelming field of perceptual data, in a sense incarnating in extreme form

73. W. E. Pelham, “Attention Deficits in Hyperactive and Learning Disabled Children,” *Exceptional Education Quarterly* 2, no. 3 (1981), p. 20.

74. The cultural and social disruptions inherent in schizophrenia have been outlined thus: “By the process of attention we thus break down and effectively categorize both the information reaching us from the environment, and that which is internally available in the form of stored past experience. By such processes we reduce, organize and interpret the otherwise chaotic flow of information reaching consciousness to a limited number of differentiated, stable and meaningful percepts from which reality is constructed. . . . Now let us suppose there is a breakdown in this selective-inhibitory function of attention. Consciousness would be flooded with an undifferentiated mass of incoming sensory data, transmitted from the environment via the sense organs. To this involuntary tide of impressions there would be added the diverse internal images, and their associations, which would no longer be coordinated with incoming information. Perception would revert to the passive and involuntary assimilative process of early childhood and, if the incoming flood were to carry on unchecked, it would gradually sweep away the stable constructs of a former reality.” Andrew McGhie and James Chapman, “Disorders of Attention and Perception in Early Schizophrenia,” *British Journal of Medical Psychology* 34 (1961), pp. 110–111. Recent studies, though, have questioned the usefulness of the concept of a monolithic attentional impairment in schizophrenia and asserted that unitary models of attention have limited explanatory value. See, for example, J. T. Kenny and H. Meltzer, “Attention and Higher Cortical Functions in Schizophrenia,” *Journal of Neurophysiological and Clinical Neurosciences* 3 (1991), pp. 269–275.

the modern paradigm of sensory overload. The Swiss psychiatrist Eugen Bleuler, credited with introducing the term schizophrenia, observed a profound disturbance of the inhibiting properties of attention: “The selectivity which normal attention ordinarily exercises among the sensory impressions can be reduced to zero so that almost everything is recorded that reaches the senses.”⁷⁵

The thematic of inhibition has been an integral part of many influential theories of attention, for example in the work of Wundt, which exemplifies the replacement of Kant’s transcendental unity of apperception with merely psychological processes of synthesis and integration. Selective attention, for Wundt, was the single most important psychic category because of its essential (but not a priori) role in producing an effective unity of consciousness and perception. His postulation of an attention center located in the frontal cerebral lobes was particularly influential.⁷⁶ Suffused with many of the social assumptions of evolutionary thought in the 1870s and 1880s, his account defined attention as one of the highest integrating functions (distinct from the automatic functions of the lower brain and spinal column) within an organism whose makeup was emphatically hierarchical.⁷⁷ More significantly, Wundt’s model of attention, which he effectively equated with will, was founded on the idea that various sensory, motor, and mental processes were necessarily *inhibited* in order to achieve the restricted clarity and focus that characterized attention.⁷⁸ It was a powerful formulation to be found in many variations throughout the 1880s and 1890s.

The idea of inhibition and anesthesia as constitutive parts of perception is an indication of a dramatic reordering of visibility, implying the new importance of

75. Eugen Bleuler, *Dementia Praecox, or the Group of Schizophrenias* (1911), trans. Joseph Zinkin (New York: International Universities Press, 1950), p. 68. Jan Goldstein has shown that the link between insanity and a malfunction of attentiveness goes back at least to the work of J. E. D. Esquirol around 1816, in her *Console and Classify: The French Psychiatric Profession in the Nineteenth Century* (Cambridge: Cambridge University Press, 1987), pp. 246–247.

76. Wundt, *Grundzüge der physiologischen Psychologie*, vol. 3 (1874; 6th ed. Leipzig: Engelmann, 1908), pp. 306–364; in English as *Principles of Physiological Psychology*, trans. Edward Bradford Titchener (New York: Macmillan, 1904).

77. The groundbreaking neurological work of John Hughlings Jackson was a parallel articulation of this hierarchical model, in which different functions were associated with specific areas of the nervous system: Jackson distinguished so-called “higher” functions like voluntary attentiveness from more automatic and “lower” forms of motor behavior.

78. For a detailed overview of this problem in the nineteenth century, see Roger Smith, *Inhibition: History and Meaning in the Sciences of Mind and Brain* (Berkeley: University of California Press, 1992). But the relation between attention and inhibition is also articulated in many places fully independently of neurological or physiological ideas. See, for example, F. H. Bradley, “On Active Attention,” *Mind*, n.s. 11 (1902), p. 5: “Attention will thus consist in the suppression of any psychical fact which would interfere with the object, and its essence therefore is not positive at all, but merely negative.”

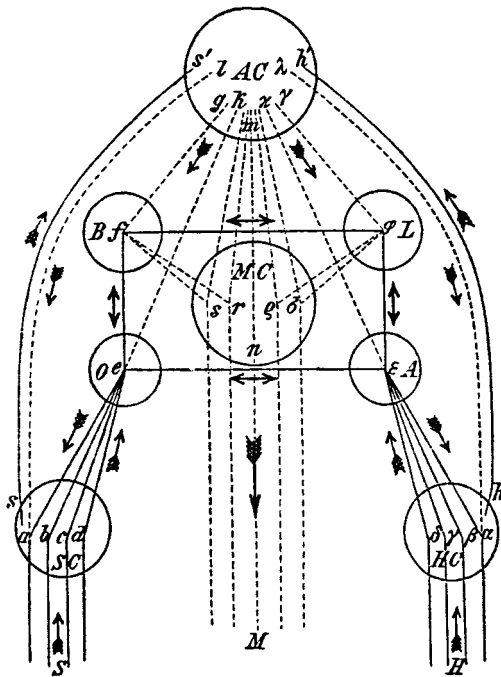

Wundt's schematic diagram of the brain, with attention center at top, 1880.

models based on an economy of forces rather than an optics of representation. Freud's formulations on the relation between perception and repression (from the "Project" in 1895 to the essay on psychogenic visual disturbances in 1910) are only the more widely known products to come out of speculation and research by others in the 1870s and 1880s.⁷⁹ Charles Fere and Alfred Binet described "the simple fact of attention" as "a concentration of the whole mind on a single point, resulting in the intensification of the perception of this point and producing all around it a zone of anesthesia; attention increases the force of certain sensations while it weakens others."⁸⁰ They specified the "negative effects of attention." Janet described how attention "suppressed" the contents of consciousness and produced a shrinkage of the visual field.⁸¹ These are indications of the irrelevance of the camera obscura model of vision, in which an ideal observer had the capacity to

79. See Anne Harrington, *Medicine, Mind, and the Double Brain: A Study in Nineteenth Century Thought* (Princeton: Princeton University Press, 1987), pp. 235–247.

80. Alfred Binet and Charles Fere, *Le magnetisme animal* (Paris: Felix Alcan, 1888), p. 239.

81. Pierre Janet, "L'attention," in Charles Richet, ed., *Dictionnaire de physiologie*, vol. 1 (Paris: F. Alcan, 1895), p. 836.

apprehend instantaneously the unedited contents of a visual field. Thus, a normative observer in the late nineteenth century began to be conceptualized not only in terms of the isolated objects of attention, but equally in terms of what is not perceived, or only dimly perceived, of the distractions, the fringes and peripheries that are excluded or shut out of a perceptual field. As I will detail in chapter four, part of this new disjunct model of vision was linked to the physiological discovery of the nonhomogeneous nature of the eye itself, with its small area of foveal clarity within a much larger field of peripheral indistinctness. However, it was the *metaphorical* and not the empirical impact of this model that became important for modern refigurations of the observer.

It should be emphasized that the themes of inhibition, exclusion, and periphery did not necessarily support a Freudian model of an unconscious actively denying certain contents to attentive awareness. Jonathan Miller has argued recently that an alternative European tradition in the nineteenth century posed the unconscious as part of a system in which *automatic* behavior was reciprocally intertwined with the changing needs of conscious activity, including attention. In contrast to the “custodial” Freudian interpretation, many nineteenth-century psychologists saw the unconscious as “actively generating the processes which are integral to memory, perception, and behavior. Its contents are inaccessible not, as in psychoanalytic theory, because they are held in strenuously preventive detention but, more interestingly, because the effective implementation of cognition and conduct does not actually *require* comprehensive awareness. On the contrary, if consciousness is to implement the psychological tasks for which it is best fitted, it is expedient to assign a large proportion of psychic activity to automatic control; if the situation calls for a high level management decision, the unconscious will freely deliver the necessary information to awareness.”⁸² Helmholtz, for example, proposed a quasi-utilitarian functioning of the mind in which sensory information that is unlikely to be useful or necessary is involuntarily unattended to. To become aware of such information (like the blind spot in our visual field) requires a special effort at reorienting one’s attention.

Darwin established a pervasive belief in the importance of attention in human evolution, identifying it as a survival mechanism: “Hardly any faculty is more important for the intellectual progress of man than the power of attention. Animals

82. Jonathan Miller, “Going Unconscious,” *New York Review of Books*, April 20, 1995, p. 64. Miller discusses the work of Sir William Hamilton, W. Benjamin Carpenter, and Thomas Laycock (the teacher of J. H. Jackson).

clearly manifest this power, as when a cat watches a hole and prepares to spring on its prey. Wild animals sometimes become so absorbed when thus engaged, that they may be easily approached.”⁸³ A certain kind of reactive attention was believed to be an essential part of human biology. This was what triggered a systemic response to novel stimuli, whether visual, olfactory, or auditory, in which the organism was instantly able to shut down (or inhibit) ongoing motor activity while focusing mental effort exclusively on the relevant stimuli, usually those related to potential predators or prey. Parallel to Wundt’s work in the 1870s were the neurological researches of the Scottish physician Sir David Ferrier, who championed the idea of localization of brain function. Ferrier developed the hypothesis of inhibitory centers in specific parts of the brain, which were effectively the physiological basis of will and attention. He demonstrated how attention and volition depended on the physiological *suppression* of movement, that is, paradoxically, how certain forms of sensorimotor activity inhibited other motor activity.⁸⁴ Thus an attentive observer might appear motionless, in a state of frozen immobility, but was in fact the site of a ferment of physiological (and motor) occurrences, upon which that relative “stasis” depended.⁸⁵ This state of heightened alertness and of intense focus on a restricted area of a sensory field could be understood in many ways. For example, it could be transposed from the animal realm of sheer survival into a biological adaptation of the organism to disciplined and productive labor within a social realm. But attention, as a shutting out, a powerful filter, could also be seen as a model of a Nietzschean forgetting, an essential precondition not merely for subsistence but for affirmation of the self through *action*.⁸⁶ Attention here has less

83. Charles Darwin, *The Descent of Man, and Selection in Relation to Sex* (1871; Princeton: Princeton University Press, 1981), p. 44. Angelo Mosso, for example, begins his chapter on attention by citing Darwin, in his *Fatigue*, p. 177. On the epistemological impact of Darwin’s work, see Robert J. Richards, *Darwin and the Emergence of Evolutionary Theories of Mind and Behavior* (Chicago: University of Chicago Press, 1987), pp. 275–294.

84. See David Ferrier, *The Functions of the Brain* (1876; New York: G. P. Putnam, 1886), pp. 463–468. See also the valuable discussion of Ferrier in Smith, *Inhibition*, pp. 116–121.

85. See, for example, Maudsley, *The Physiology of Mind*, pp. 313–315: “But it may be asked, how can motor innervation be a factor in the operation of will in a mental act when, so far as appears, no muscular act is concerned? The reply which there seems to be good warrant to make is that motor innervation invariably accompanies the simplest effort of what seems to be pure will.”

86. This sense of attention, as a forgetting that is a condition for the affirmation and self-actualization of the organism, persisted well into the twentieth century in Bergson (whose work I discuss in chapter four) and many others. See, for example, the assertion that “it is creative apperception more than anything else that makes the individual feel that life is worth living,” in Donald Winnicott, *Collected Papers* (New York: Basic Books, 1951), p. 65; or, more significantly, Abraham H. Maslow’s notion of the “peak-experience” which was widely popularized in the 1960s. Maslow describes a mode of “total

to do with a model of consciousness than with an ideo-motor network of *forces*. It is paradoxically that which immobilizes yet, if seen as a part of a biological heritage, is inseparable from mobility.

As part of the larger physiological reconfiguration of subjectivity that occurred during the nineteenth century, attention, in almost all of the varied ways it was theorized, was inseparable from physical effort, movement, or action. During the period I am examining, attentiveness was generally synonymous with an observer who was fully embodied and for whom perception coincided with physiological and/or motor activity. To specify further, there were three particularly important models through which attention as movement was understood. Occasionally elements of these models overlapped, but for the most part they stood for relatively incompatible positions. (1) Attention as a *reflex* process, part of a mechanical adaptation of an organism to stimuli in an environment. Important here is the evolutionary legacy of attention, and its origins in *involuntary* and instinctive perceptual responses. (2) Attention as determined by the operations of various *automatic* or unconscious processes or forces, a position articulated in many ways, beginning with Schopenhauer, Janet, Freud, and numerous others. (3) Finally, attention as a decisive, *voluntary* activity of the subject, an expression of its autonomous power to actively organize and impose itself on a perceived world. But even those who defended the latter position, like James or Bergson, readily acknowledged the proximity of and blurred limits between voluntary attentiveness and automatic or involuntary states.

During the 1880s the similarity between will and attention became a central issue in work of many kinds, highlighting how far removed psychological thought was now from Mill's associationism and his "psychic chemistry" of laws regarding regularities of sensations, or from Spencer's work in the 1850s that had defined experience as the *passive* response to external order. William James opened his pivotal discussion of attention with an attack on Spencer and the Mills for their repression or avoidance of the problem: "Their motive of this ignoring of the phenomenon of attention is obvious enough. These writers are bent on showing how the higher faculties of the mind are pure products of 'experience;' and experience is supposed to be something simply *given*. Attention, implying a degree of reactive

attention" in which it is "as if the world were forgotten, as if the percept had for the moment become the whole of Being," in *Toward a Psychology of Being* (New York: Van Nostrand Reinhold, 1968), p. 74. The enduring (or recyclable) nature of such formulations is evident in the 1990s in such best-selling self-improvement handbooks as Mihaly Csikszentmihalyi, *Flow: The Psychology of Optimal Experience* (New York: Harper, 1990), p. 33: "Attention is our most important tool in the task of improving the quality of our experience."

spontaneity, would seem to break through the circle of pure receptivity . . . the creature as absolutely passive clay, upon which experience rains down.”⁸⁷ In a general way the shift that takes place in the 1870s is from the *structural* psychology of associationism to various kinds of *functional* psychological accounts.⁸⁸ The change is, in part, the product of the increasing importance and richness of a physiological understanding of the human subject. The poverty and inadequacy of associationist theories of knowledge became evident in the face of a widespread coming to terms with the subject as an active center of striving behavior and as a composite of processes unfolding in time.

Thus attention flourished and persisted as a problem, even as various systems of thought in which it was positioned became obsolete. For example, in the 1870s and 1880s, many social thinkers and psychologists either closely associated or identified attention with will. But as historian Lorraine Daston has convincingly shown, the movement toward a more rigorously “scientific psychology,” which gathered momentum and institutional significance in the 1890s, was a joining of forces “in the campaign against consciousness, volition, introspection and other distinctive aspects of mind.” By the turn of the century, “the theory of the will became the common target of an attack launched by several different schools of American and British psychology.”⁸⁹ But if the will, the mind, and introspection were superfluous elements, attention remained as an inescapable component of an institutional construction of subjectivity. Hugo Münsterberg and James McKeen Cattell (whose work I discuss in chapter four) can stand as examples of this jettisoning of any notion of an active will, while still retaining attention as an important problem in various attempts to align psychology with strategies of social control. In a related way today, attention remains an indispensable category for institutional discourses and techniques of the subject, not only in its obvious social manifestations like the debate around ADD but also within the sprawling precincts of the cognitive sciences, even as the relevance or existence of “mind” and

87. James, *Principles of Psychology*, vol. 1, pp. 402–403. See the excellent chapter on James’s contribution to the problem of attention in Gerald E. Myers, *William James: His Life and Thought* (New Haven: Yale University Press, 1986), pp. 181–214.

88. See George Herbert Mead, *Movements of Thought in the Nineteenth Century*, vol. 2 (Chicago: University of Chicago Press, 1936), pp. 386–387. Mead writes: “The structure of the act is the important character of conduct. This psychology is also called motor psychology, as over against the older psychology of sensation; voluntary psychology, as over against the mere association of ideas with each other.”

89. Lorraine J. Daston, “The Theory of Will versus the Science of Mind,” in William R. Woodward and Timothy G. Ash, eds., *The Problematic Science: Psychology in Nineteenth Century Thought* (New York: Praeger, 1982), pp. 88–115.

“consciousness” is contested in those same domains. Both “attention” and “consciousness” are historically constructed notions, and over the last century they have had a variable and independent relation to each other: attention as part of an account of subjectivity is not inherently synonymous with consciousness.⁹⁰

This noncoincidence of attention and consciousness is crucial here. From a certain vantage point, the use of the problem of attention as the basis for an investigation of modernity in the late nineteenth century may seem out of step with a whole legacy of recent critical practice. That is, attention might seem superficially to be a return to traditional problems of an epistemological nature, problems that were radically transformed or made irrelevant by the modern shift to semantic and semiotic frameworks of analysis, which Richard Rorty has described as a move “from epistemology to hermeneutics.”⁹¹ That shift is demonstrated most vividly in the parallel work of, for example, Mallarmé, Nietzsche, and Peirce (and later of Wittgenstein and Heidegger): thinkers operating in circumstances where it is no longer a question of how an already constituted subject knows or perceives the objectivity of an external world but how a subject is provisionally constructed through language and other systems of social meaning and value. Within this syntactic-semantic remaking of epistemology, the study of the function of various psychic *faculties* became increasingly irrelevant. I am suggesting, however, that the emergence of attention as a way of describing or explaining a perceiving subject is in fact an indication of the same general epistemological crisis, the termination of various analyses of consciousness, and the increasing insignificance of the dualistic models within which classical epistemology had operated. Once an observer was understood in terms of the essential subjectivity of vision, attention became a constitutive (and destabilizing) component of perception. The very uncertainty and vagueness about the nature of attention was an indication of the obsolescence of older theories of perception. Attention implied that cognition could no longer be conceived around the unmediated givenness of sense data. To use Peircean terms, it made a previously dyadic system of subject-object into a triadic one, with the third element constituted by a “community of interpretation”: a shifting and intervening space of socially articulated physiological functions, in-

90. Ludwig Wittgenstein, as an anti-Cartesian, was acutely aware of this noncoincidence of perception, consciousness, and attention: “But don’t the words ‘I perceive’ here shew that I am attending to my consciousness?—which is ordinarily not the case,—If so, then the sentence ‘I perceive I am conscious’ does not say that I am conscious, but that my attention is disposed in such-and-such a way.” *Philosophical Investigations*, trans. G. E. M. Anscombe (New York: Macmillan, 1953), p. 125.

91. Richard Rorty, *Philosophy and the Mirror of Nature* (Princeton: Princeton University Press, 1979), p. 315.

stitutional imperatives, and a wide range of techniques, practices, and discourses relating to the perceptual experience of a subject in time. Attention here is not reducible to attention *to* something. Thus attention within modernity is constituted by these forms of *exteriority*, not the intentionality of an autonomous subject. Rather than a faculty of some already formed subject, it is a sign, not so much of the subject's disappearance as of its precariousness, contingency, and insubstantiality.

While it is easy and appropriate to situate the wide-ranging research on attention within the requirements of larger disciplinary and administrative apparatuses for the management and control of human subjects, it is also important to emphasize another related dimension of the knowledge accumulated within the newly configured human sciences in the nineteenth century. Foucault has taken us through what he calls the great eschatological dream of the nineteenth century, which was "to make this knowledge of man exist so that man could be liberated by it from his alienations, liberated from all the determinations of which he was not the master, so that he could, thanks to this knowledge of himself, become again or for the first time master of himself, self-possessed. In other words, one made of man an object of knowledge so that man could become subject of his own liberty and of his own existence."⁹² Thus the attempt to determine empirically the specific physiological and practical conditions under which a perceiving subject could be most acutely attentive to the world, or could stabilize and objectify the contents and relations within that world through an exercise of a sovereign and attentive will, would also be a claiming of that subject's self-possession as potential master and conscious organizer of that perceptible world.⁹³ But scientific psychology never was to assemble knowledge that would compel the efficient functioning of an attentive subject, or that would guarantee a full co-presence of the world and an attentive observer.⁹⁴ Instead, the more one investigated, the more attention was shown to contain within itself the conditions for its own

92. Michel Foucault, "Foucault Responds to Sartre," in *Foucault Live*, trans. John Johnston (New York: Semiotexte, 1989), p. 36. Interview originally published in *La Quinzaine littéraire*, March 1–15, 1968.

93. Nietzsche made this link between attention and the will to mastery: "That which is termed 'freedom of the will' is essentially the affect of superiority in relation to him who must obey: 'I am free, "he" must obey'—this consciousness is inherent in every will; and equally so the straining of the attention, the straight look that fixes itself exclusively on one aim, the unconditional evaluation that 'this and nothing else is necessary now,' the inward certainty that obedience will be rendered—and whatever else belongs to the position of the commander." *Beyond Good and Evil*, trans. Walter Kaufmann (New York: Random House, 1966), pp. 25–26 (sec. 19).

94. A sense of this failure is implicit in Hermann Ebbinghaus's blunt conclusion in 1905: "Der Aufmerksamkeit ist ein rechte Verlegenheit der Psychologie [Attention is a real embarrassment to psychology]," *Grundzüge der Psychologie*, vol. 1, p. 611.

undoing—attentiveness was in fact continuous with states of distraction, reverie, dissociation, and trance. Attention finally could not coincide with a modern dream of autonomy.



It was these physiological conceptions of attention that so much late nineteenth- and early twentieth-century aesthetic theory attempted to escape from, by posing various modalities of contemplation and vision that were radically cut from the processes and activities of the body.⁹⁵ The whole neo-Kantian legacy of a disinterested aesthetic perception, from Konrad Fiedler, T. E. Hulme, and Roger Fry up to more recent “formalisms,” has been founded on the desire to escape from bodily time and its vagaries. Hulme, for example, believed the artist was someone in whom “nature had forgotten to attach their faculty for perception to their faculty for action,” and outlined an aesthetic attentiveness that is “emancipated” from the physiological.⁹⁶ Much modernist art and music theory has been based on dualistic systems of perception in which a rapt, timeless presence of perception is contrasted with lower, mundane or quotidian forms of seeing or listening.⁹⁷ Within the visual arts, Rosalind Krauss argues that modernism imagines two orders, the first of which is “empirical vision, the object as it is ‘seen,’ the object bounded by its contours, the object modernism spurns. The second is that of the formal conditions of the possibility of vision itself, the level at which ‘pure’ form operates as a principle of coordination, unity, structure: visible but unseen,” and Krauss outlines how temporality is necessarily excluded from the latter.⁹⁸ Modernist vision with its “all-at-oneness,” she contends, is founded on the cancellation of the empirical conditions of perception, including the experience of successiveness.

What became clear, though often evaded, in work of many different kinds on attention was what a volatile concept it was, and how incompatible with any

95. In his 1909 “An Essay in Aesthetics,” Roger Fry portrays the aesthetic faculty as a form of perception that was cut off from “the complex nervous machinery” of the body and the instincts. “The whole of animal life, and a great part of human life, is made up of these instinctive reactions to sensible objects, and their accompanying emotions,” while for Fry “imaginative life” is about contemplation disconnected from the possibility of action. In Fry, *Vision and Design* (Cleveland: Meridian, 1956), pp. 17–18. Fry elsewhere argued for “the a priori case for the existence in all aesthetic experiences of a special orientation of the consciousness, and, above all, a special focussing of the attention, since the act of aesthetic apprehension implies an attentive passivity to the effects of sensations apprehended in their relations.” Fry, *Transformations: Critical and Speculative Essays on Art* (London: Chatto and Windus, 1927), p. 5.

96. T. E. Hulme, *Speculations* (New York: Harcourt, Brace and Co., 1924), pp. 154–157.

97. See, for example, the opposition between “free” artistic perception and “unfree” nonartistic perception in Konrad Fiedler, *On Judging Works of Visual Art* (1876), trans. Henry Shaefer-Simmern (Berkeley: University of California Press, 1949).

98. Rosalind E. Krauss, *The Optical Unconscious* (Cambridge: MIT Press, 1993), p. 217.

model of a sustained aesthetic gaze. Attention always contained within itself the conditions for its own disintegration, it was haunted by the possibility of its own excess—which we all know so well whenever we try to look at or listen to any one thing for too long.⁹⁹ In any number of ways, attention inevitably reaches a threshold at which it breaks down. Usually it is the point at which the perceptual identity of its object begins to deteriorate and in some cases (as with certain sounds) disappear altogether. Or it can be a limit at which attention imperceptibly mutates into a state of trance or even autohypnosis. In one sense, attentiveness was a critical feature of a productive and socially adaptive subject, but the border that separated a socially useful attentiveness and a dangerously absorbed or diverted attention was profoundly nebulous and could be described only in terms of performative norms. Attention and distraction were not two essentially different states but existed on a single continuum, and thus attention was, as most increasingly agreed, a dynamic process, intensifying and diminishing, rising and falling, ebbing and flowing according to an indeterminate set of variables.¹⁰⁰ Philosopher Alfred Fouillee succinctly expressed the problem: “Concentration of the will and of attention on anything will lead to exhaustion of attention and to a paralysis of the will.”¹⁰¹ In this sense attention had certain thermodynamic qualities by which a given force could assume more than one form.¹⁰² Emile Durkheim, in his epistemological writings of the 1890s, made explicit the inseparability of attention and distraction within a larger discussion of the blindness inherent in perception: “We

99. See Théodule Ribot, *The Psychology of Attention* (1889; Chicago: Open Court, 1896), p. 3: “Attention is a state that is fixed. If it is prolonged beyond a reasonable time . . . everybody knows from individual experience, that there results a constantly increasing cloudiness of the mind, finally a kind of intellectual vacuity, frequently accompanied by vertigo.” See also Ribot’s account of pathological failures of attention in his *The Diseases of the Will*, trans. Merwin-Marie Snell (Chicago: Open Court, 1894), pp. 72–76.

100. Gustav Fechner was one of the first to articulate this continuum with some specificity. He outlines a reciprocal relation between attention and “partial sleep” in his *Elemente der Psychophysik*, vol. 2 (Leipzig: Breitkopf und Hartel, 1860), pp. 452–457. Kurt Goldstein wrote that unless attention has “a differential emphasis” it will shift into “a pathological boundness to stimuli,” and he insists “that distractibility and abnormal fixation are expressions of the same functional change under different conditions.” Goldstein, “The Significance of Psychological Research in Schizophrenia,” *Journal of Nervous and Mental Disease* 97, no. 3 (March 1943), p. 272.

101. Alfred Fouillee, “Le physique et le mental: A propos de l’hypnotisme,” *Revue des Deux Mondes* 105 (May 1, 1891), p. 438.

102. Ernst Mach was one of many who, in the 1880s, grasped its apparently paradoxical nature: “Where the development of intelligence has reached a high point, such as is presented now in the complex conditions of human life, representations may frequently absorb the whole of attention, so that events in the neighborhood of the reflecting person are not noticed, and questions addressed to him are not heard;—a state which persons unused to it are wont to call absent-mindedness, although it might with more appropriateness be called present-mindedness.” Mach, *Contributions to the Analysis of the Sensations* (1885), trans. C. M. Williams (La Salle, Ill.: Open Court, 1890), p. 85.

are always to a certain extent in a state of distraction, since the attention, in concentrating the mind on a small number of objects, blinds it to a greater number of others; all distraction has the effect of withdrawing certain psychic states from consciousness which do not cease to be real for all that, since they continue to function.”¹⁰³

In this sense my work qualifies some assumptions that have been part of a long-established critical characterization of modernity in terms of experiences of distraction. In particular, the work of Georg Simmel, Walter Benjamin, Siegfried Kracauer, Theodor Adorno, and others presumed that a distracted perception was central to any account of subjectivity within modernity.¹⁰⁴ The German word *Zerstreung* figured in numerous critical analyses that were indebted to a Kantian theory of knowledge. Here *Zerstreung* referred to a dispersion or scattering of perceptions outside of any necessary synthesis, perceptions as “merely a blind play of representations, less even than a dream.”¹⁰⁵ One of the enduring legacies of this work has been accounts of modernity as a process of fragmentation and destruction in which premodern forms of wholeness and integrity were irretrievably broken up or degraded through technological, urban, and economic reorganizations. One of the premises of Fiedler’s *On Judging Visual Works of Art* (1876) was the diagnosis of a “decay” in the capacity for perception, and this text stands as an important early instance of generalized historical assumptions in which premodern modalities of looking and listening are either implicitly or explicitly predicated as richer, deeper, or more valuable.¹⁰⁶ This evaluation certainly was behind Fiedler’s attempt to establish an “objectivist” aesthetics in which the “presence” of pure visible form is accessible only to an attentive “seeing” cut off from any of the subjective psychological conditions of vision.¹⁰⁷ By the turn of the century Simmel

103. Emile Durkheim, “Individual and Collective Representations,” in his *Sociology and Philosophy*, trans. D. F. Pocock (Glencoe, Ill.: Free Press, 1953), p. 21.

104. See, for example, Georg Simmel, “The Metropolis and Mental Life,” in his *On Individuality and Social Forms* (Chicago: University of Chicago Press, 1971), pp. 324–339; Walter Benjamin, “On Some Motifs in Baudelaire,” in his *Illuminations*, trans. Harry Zohn (New York: Schocken, 1968), pp. 155–200; Siegfried Kracauer, “Cult of Distraction,” in *The Mass Ornament*, trans. Thomas Y. Levin (Cambridge: Harvard University Press, 1995), pp. 323–330; and Theodor Adorno, “On the Fetish-Character in Music and the Regression of Listening,” in Andrew Arato and Eike Gebhardt, eds., *The Essential Frankfurt School Reader* (New York: Urizen, 1978), pp. 270–299.

105. Kant, *Critique of Pure Reason*, p. 139.

106. Fiedler, *On Judging Works of Visual Art*, p. 40.

107. See the penetrating discussion of Fiedler in Ernst Cassirer, *The Philosophy of Symbolic Forms*, vol. 4: *The Metaphysics of Symbolic Forms*, trans. John Michael Krois (New Haven: Yale University Press, 1996), pp. 81–85: “The psychological context may not be confused with the constitutive: the feelings

had provided an exemplary account of how modern urban life as “the swift and continuous shift of external and internal stimuli” contrasted with “the slower, more habitual, more smoothly flowing rhythm of the sensory-mental phase” of premodern social life. A related position saw the fragmentation implicit in modernity as destructive to a whole set of traditional artistic and cultural values, but in this view distraction was a necessary part of a process of overcoming the bankruptcy of bourgeois aesthetics. Nonetheless there is an overriding sense of distraction as the product of “decay” or “atrophy” of perception within a larger deterioration of experience.¹⁰⁸ Adorno, for example, writes about distraction as “regression,” as perception that has “arrested at the infantile stage” and for which deep “concentration” is no longer possible.¹⁰⁹ For the poet Rilke, writing in the early twentieth century, authentic attention was the precious and rare survival of a lost ideal of artisanal absorption in work, now exiled to the margins of a mechanized and routinized world. The sculptor Rodin incarnated for Rilke “the attentive one whom nothing escapes, the lover who continually receives, the patient one who does not count his time and does not think of wanting the next thing. For him what he gazes at and surrounds with gazing is always the only thing, the world in which everything happens . . . and this way of looking and living is so fixed in him because he acquired it as a handworker.”¹¹⁰

My contention, on the contrary, is that modern distraction was *not* a disruption of stable or “natural” kinds of sustained, value-laden perception that had existed for centuries but was an *effect*, and in many cases a constituent element, of the many attempts to produce attentiveness in human subjects.¹¹¹ If distraction emerges as a problem in the late nineteenth century, it is inseparable from the parallel construction of an attentive observer in various domains. Although Benjamin, in some of his work, makes affirmative claims for distraction (suggesting that

that are elicited while taking in a work of art may not be regarded as belonging to its essential aspects. . . . Fiedler in the end regards everything that belongs to the ‘subjective’ side, to the ‘emotional’ world instead of the world of the visible, as merely *obscuring* pure visibility.”

108. See Miriam Hansen’s analysis of Benjamin’s ambivalent historicization of perception in “Benjamin, Cinema and Experience,” *New German Critique* 40 (Winter 1987), pp. 179–224.

109. Adorno, “On the Fetish-Character in Music and the Regression of Listening,” p. 288.

110. Rainer Maria Rilke, *Letters of Rainer Maria Rilke 1892–1910*, trans. Jane B. Green and M. D. Norton (New York: Norton, 1945), letter to Lou Andreas-Salome, August 8, 1903.

111. John Dewey is one of many who, by the 1880s, had established the inseparability of a normative model of attention from experiences of shock, dissociation, and novelty: “A shock of surprise is one of the most effective methods of arousing attention. The unexpected in the midst of the routine is the accentuated. The very contrast between the two rivets attention, and more effectively dissociates each from the other. Thus variety and mobility of psychic life are secured.” Dewey, *Psychology*, p. 127.



Fernand Khnopff, Listening to Schumann, 1883.

the disruption inherent in shock and distraction held forth the possibility of new modes of perception), he does so in terms of a fundamental duality in which an absorbed contemplation, purified of the excess stimuli of modernity, was the other term.¹¹² “Distraction and concentration form polar opposites,” declares Benjamin in his well-known discussion of architecture and film as two paradigms of modern

112. Of course in German there is no cognate of *contemplation*. Nonetheless it is worth remembering the theological resonances of this Latinate word. Not only does it mean “viewing or considering with continued attention,” but as Adorno’s early Frankfurt Institut colleague, Paul Tillich, later wrote: “Contemplation means going into the temple, into the sphere of the holy, into the deep root of things, into their creative ground.” Tillich, *The New Being* (New York: Scribner’s, 1955), p. 130. For Benjamin, even Franz Kafka, one of his exemplary modernists, is characterized by a problematic relation to secularized modalities of perception: “Even if Kafka did not pray—and this we do not know—he still possessed in the highest degree what Malebranche called ‘the natural prayer of the soul’: attentiveness. And in this attentiveness he included all living creatures, as saints include them in their prayers.” Benjamin, *Illuminations*, p. 134.

“reception in a state of distraction.”¹¹³ I argue, instead, that attention and distraction cannot be thought outside of a continuum in which the two ceaselessly flow into one another, as part of a social field in which the same imperatives and forces incite one and the other.

Among the many elements that shaped Benjamin’s historicization of perception was the work of the Viennese art historian Alois Riegl. In his 1902 book *The Dutch Group Portrait*, Riegl outlined a countermodel of attention with which he opposed not so much contemporary forms of distraction but rather modernized forms of subjectivity, characterized by absorption in a physiologically grounded perception. If Riegl’s work was informed by his familiarity with the research of Wundt and others, his specific account of attentiveness sought to resolidify the unitary self that scientific psychology was in the process of dismantling. The transitory and provisional nature of mental states and perceptual experiences which Wundt and others detailed were quite incompatible with Riegl’s postulation of a subject whose integrity depended on a reciprocal relation between an unwavering subjective attentiveness and a coherent objective world. For Riegl, the individual defined itself through the exercise of a directed concentration that exceeded the domain of mere psychophysiology. And in *The Dutch Group Portrait* he made clear that his privileged model of the individual observer presupposed an ideal of attentive *intersubjectivity*, as opposed to modern forms of interiority, absorption, and psychic isolation, or to the dissolution of this communal world which he saw figured within the general cultural phenomenon of “Impressionism.” Thus the group portraits of seventeenth-century Holland provided, at the beginning of the twentieth, a utopian figuration of a world of mutual communication (a secular equivalent of religious experience) and a world in which art would be inseparable from an imaginary democratic harmony of individual and community. For Riegl the goal of these paintings was the “representation of a selfless psychological element (attention), by means of which the individual psyches were forged together as a whole in the consciousness of the beholding subject.”¹¹⁴ Modern distraction could only erode such a possibility. But for Riegl, the dream of community, of a hushed moment of psychic communion, as figured, say, in Rembrandt’s *Syndics*, existed as an aesthetic construction to be apprehended by the individual as a solitary observer. Without question, the new forms of collective reception, such as

113. Benjamin, *Illuminations*, pp. 239–240.

114. Alois Riegl, “The Dutch Group Portrait (excerpts),” trans. Benjamin Binstock, *October* 74 (Fall 1995), p. 11. See Ignasi de Sola-Morales’s valuable discussion of subjectivity in Riegl and Fiedler, in “Toward a Modern Museum: From Riegl to Giedion,” *Oppositions* 25 (Fall 1982), pp. 68–77.

cinema, concretized in attentive mass audiences around 1900, would have disheartened Riegl, whose ideal could only be an elitist and regressive fantasy of a premodern and ethically charged attentiveness.¹¹⁵

Various accounts of modern subjectivity have positioned attentiveness as a fundamental product of Western modernity in general, well beyond my frame of the late nineteenth century. Ferdinand Tönnies, in his influential distinction between *Gemeinschaft* and *Gesellschaft*, singles out attention as a constitutive feature of the latter, as something characteristic of modern forms of isolation and fragmentation that supplanted premodern communal relations. In *Gesellschaft* the conduct of commerce and trade based on deliberation depends on the social cultivation of attentive habits: “The exertion of the mind on the imagination of the desired object, or the conscious or rational attention, i.e. attention linked to thought. This is a form which underlies all rational activities. One focusses, as it were, one’s telescope on that object. . . . He will ‘open his eyes’ and ‘draw his attention’ to it.”¹¹⁶ Throughout Nietzsche’s work one finds a related account of modern culture in which a narrowed attentiveness is central. As I suggested earlier, for Nietzsche attention also held the possibility of an absorption, a forgetting that could be a precondition for life-affirming action, even a forgetting that could be the attaining of instants of eternity within the flux of human time.¹¹⁷ In a more pervasive and degraded form,

115. See the discussion of Riegl and attention in Margaret Olin, *Forms of Representation in Alois Riegl’s Theory of Art* (University Park: Pennsylvania State University Press, 1992), pp. 155–169. Olin stresses that for Riegl *Aufmerksamkeit*, among other things, “denotes a polite or deferential act directed toward another.”

116. Ferdinand Tönnies, *Community and Society* (1887), trans. Charles P. Loomis (East Lansing: Michigan State University Press, 1957), p. 145. See the assessment of Tönnies in Harry Liebersohn, *Fate and Utopia in German Sociology 1870–1923* (Cambridge: MIT Press, 1988), pp. 11–39.

117. Obviously, this touches on the proximity of the problem of attention to the vast history and sociology of “spiritual exercises.” But in practices that sought the apprehension of a pure undifferentiated essence, the paradoxical nature of attention was always a fundamental problem; it allowed a certain initial concentration of the mind, but inevitably its intrinsic temporal limits still anchored the subject in a transitory world of comings and goings. An early Buddhist text insists: “All kinds of ideation are to be discarded as fast as they arise; even the notions of controlling and discarding are to be got rid of. One’s mind should become like a mirror, reflecting things, but not judging them or retaining them. Conceptions arising from the senses and lower mind will not take form of themselves, unless they are grasped by the attention; if they are ignored, there will be no appearing and disappearing. The same is true of conditions outside the mind; they should not be allowed to engross one’s attention and so to hinder one’s practice . . . there should be no lingering notions of the self.” Cited in Aldous Huxley, *The Perennial Philosophy* (New York: Harper, 1944), p. 290. For an exemplary recent text, see J. Krishnamurti, *The Flame of Attention* (New York: Harper, 1984). For Western research on this problem see, for example, the discussion of studies on attention and meditation in Marjorie Schuman, “The Psychophysiological Model of Meditation and Altered States of Consciousness: A Critical Review,” in Julian Davidson and Richard Davidson, eds., *The Psychobiology of Consciousness* (New York: Plenum Press, 1980), pp. 333–378. Also relevant are the remarks on attention and meditative practices in Georges Bataille, *Inner Experience*, trans. Leslie Anne Boldt (Albany: SUNY Press, 1988), pp. 15–18.

however, he sees it as a mere focusing on the present moment, as it was for Tonies: “Now only one kind of seriousness remains in the modern soul, that directed towards the news brought by the newspaper or the telegraph. To employ the moment and, so as to profit from it, to assess its value as quickly as possible!—one might believe that modern man has retained only one virtue, that of *presence of mind*.”¹¹⁸ Nietzsche, then, suggests the dilemma: an absorbed attentiveness is both essential for the creative exceeding of the limits of individuality and at the same time a necessary part of the individual’s functioning within a modern world of economic facts and quantities.

In the twentieth century, this general account of modern subjectivity is developed in many places. For example, Max Horkheimer, writing in 1941, described the subject within modern culture as needing the automaton’s ability to react correctly: “The individual no longer has any future to care for, he has only to be ready to adapt himself, to follow orders, to pull levers, to perform ever different things which are ever the same. The social unit is no longer the family but the atomic individual. . . . Contemporary individuals, however, need presence of mind even more than muscles; the ready response is what counts, affinity to every kind of machine, technical, athletic, political.”¹¹⁹ After World War II, David Riesman developed his characterological model of the “other-directed” person, partly in terms of the sensory overload and perceptual acceleration of a social field in which “work and leisure are interlaced.” This new cosmopolitan individual is the product of the modernized “social environment to which he early becomes attentive. . . . The other-directed person must be able to receive signals from far and near; the sources are many, the changes rapid. What can be internalized, then, is not a code of behavior but the elaborate equipment needed *to attend* to such messages and occasionally to participate in their circulation. As against shame and guilt controls, though of course these survive, one prime psychological lever of the other-directed person is a diffuse anxiety. This control equipment, instead of being like a gyroscope, is like a radar.”¹²⁰

I will conclude this section by recalling some of Hannah Arendt’s broad reflections in her *The Human Condition*. Modernity, she contends, involves not

118. Friedrich Nietzsche, *Untimely Meditations*, trans. R. J. Hollingdale (Cambridge: Cambridge University Press, 1983), p. 219; emphasis added.

119. Max Horkheimer, “The End of Reason,” in Arato and Gebhardt, eds., *The Essential Frankfurt School Reader*; p. 38.

120. David Riesman, *The Lonely Crowd: A Study of the Changing American Character*, rev. ed. (New York: Doubleday, 1953), pp. 41–42; emphasis added.

simply a reversal of the *vita contemplativa* and the *vita activa*, of the relative values of thinking (*theoria*) and doing, but in fact the destruction of contemplation in its original sense altogether. The modern privileging of making and fabricating rendered meaningless the idea of contemplation as beholding the truth. “After being and appearance had parted company and truth was no longer supposed to appear, to reveal and disclose itself to the mental eye of the beholder,” the emergence of modern forms of beholding, of attention, is inseparable from the dissolution of anything fixed, permanent, or eternal.¹²¹ Attention can be understood through Arendt’s account of forms of looking that are compatible with “the principle of interchangeability, then the relativization, and finally the devaluation of all values.”¹²²



Within Arendt’s account of modernity, one of the values that emerges to supplant traditional beliefs is “the principle of life itself.” She singles out Marx, Nietzsche, and Bergson as thinkers who equate Life and Being. To them, life is privileged over the problem of consciousness, which is too bound up in an older static model of contemplation and truth. But, as Arendt argues, Man “did not gain life, strictly speaking, either; he was thrust back upon it, thrown into the closed inwardness of introspection, where the highest he could experience were the empty processes of reckoning of the mind, its play with itself. The only contents left were appetites and desires, the senseless urges of the body which he mistook for passion and which he deemed to be ‘unreasonable’ because he found he could not ‘reason,’ that is, not reckon with them. The only thing that could now be potentially immortal . . . was life itself, that is the possibly everlasting life process of the species mankind.”¹²³ One of the places where we can first discern this turbulent

121. Hannah Arendt, *The Human Condition* (Chicago: University of Chicago Press, 1958), p. 290. It’s possible to associate Arendt’s historical schema with Martin Heidegger’s characterizations of the primordial “self-disclosing look” of the ancient Greeks which “makes presence possible,” and the “glaring, predatory look” of the modern subject “by means of which beings are, so to say, impaled and become in this way first and foremost objects of conquest,” in his *Parmenides*, trans. Andre Schuwer and Richard Rojewicz (Bloomington: Indiana University Press, 1992), p. 108.

122. Arendt, *The Human Condition*, p. 307. Remarking on the “dazed, ‘tranquillized,’ functional type of behavior” characterizing mid-twentieth-century Western societies, Arendt presciently concludes (p. 322): “It is quite conceivable that the modern age—which began with such an unprecedented and promising outburst of human activity—may end in the deadliest, most sterile passivity history has ever known.” See the related discussion of modernity “as a process that will abolish the distinction between private and public consciousness” in Hans Magnus Enzensberger, “The Industrialization of the Mind,” in his *Critical Essays*, ed. Reinhold Grimm and Bruce Armstrong (New York: Continuum, 1982), pp. 3–14. Also important is the historical account of the shifting relation between contemplation and leisure in Sebastian de Grazia, *Of Time, Work, and Leisure* (New York: Twentieth Century Fund, 1962), pp. 19–28.

123. Arendt, *The Human Condition*, pp. 320–321.

transition from a philosophy of consciousness (and form) to a philosophy of life, where the irrational and dynamic character of subjectivity becomes constitutive of truth, is in the work of Schopenhauer, one of the first major nineteenth-century thinkers to detail the unstable and specifically *temporal* nature of perception.¹²⁴ Writing in 1844, he notes the irreducibly fragmentary and distracted character of subjective experience:

The intellect apprehends only successively, and to grasp one thing it must give up another, retaining nothing of it but traces which become weaker and weaker. The idea that is now vividly engrossing my attention is *bound* after a little while to have slipped entirely from my memory. . . .

Sometimes external impressions of sense throng in on it, disturbing it and interrupting it, and forcing the strangest and oddest things on it at every moment; sometimes *one* idea draws in *another* by the bond of association, and is itself displaced by it; finally, even the intellect itself is not capable of sticking very long and continuously to *one* idea. On the contrary, just as the eye, when it gazes for a long time at *one* object, is soon not able to see it distinctly any longer, because the outlines run into one another, become confused, and finally everything becomes obscure, so also through long-continued rumination on *one* thing our thinking gradually becomes confused and dull, and ends in complete stupor.¹²⁵

Schopenhauer is one of the earliest to grasp the link between attention and perceptual disintegration, and he compares the “defective” and “fragmentary” nature of subjective attentiveness to “a magic lantern, in the focus of which only one picture can appear at a time; and every picture, even when it depicts the most noble thing, must nevertheless soon vanish to make way for the most different and even most vulgar thing.”¹²⁶ Part of Schopenhauer’s cultural modernity is his identification of temporality itself as a source of subjective anguish. Human beings, he says, would seem “strange and pitiable” to “beings of a higher order, whose

124. Around the same time, Johann Friedrich Herbart intuited the disorder implicit in subjective experiences of succession (the way perception was effectively a series of fusions, fadings, blendings, and displacements); but his work was one of many intellectual undertakings in the first half of the nineteenth century that attempted to determine laws of association by which perception had an inherent logic and coherence. See my discussion of Herbart in *Techniques of the Observer*, pp. 100–102.

125. Schopenhauer, *The World as Will and Representation*, vol. 2, pp. 137–138.

126. *Ibid.*, p. 138.

intellect did not have time as its form.”¹²⁷ Time here has none of its Kantian characteristics: there is no longer any guarantee of orderliness to the contents of consciousness, and a window opens onto the cognitive chaos of modernity against which attention will be conjured up to do battle. Schopenhauer describes “the extremely heterogeneous mixture of fragments of representations and of ideas of every kind which are constantly crossing one another in our heads.”¹²⁸ Obviously the question of time has been part of Western epistemological thought since its beginnings, but what is decisively new by the 1830s is the pervasive recognition of the *physiological* conditions of knowledge, paralleling the rapid growth of the empirical study of the human body. The problem of consciousness becomes inseparable from the question of physiological temporality and process.¹²⁹ Beginning with Schopenhauer and continuing into the early twentieth century in Bergson and Whitehead, there are a diverse range of attempts to articulate epistemological positions that take account of the shifting processual nature of a physiological subject who effectively coincides with the ceaseless pulsings and animations of the body. For it is the specific temporality of the body that annihilated the possibility of subjective *reflection* in the Cartesian sense and that also more gradually undermined accounts of perception based on principles of *association* of discrete elements. Proponents of physiological optics asked with skepticism: when did an observer ever demonstrably experience a stable or discrete “perception”? Within this problematic, Ernst Cassirer disparagingly identifies Schopenhauer’s work as the first modern philosophical project founded on a model of an “immediate instinctive *intuition*” rather than conceptual reflection.¹³⁰

One of the most significant moves of Schopenhauer’s entire work is his rejection of Kant’s notion of the transcendental synthetic unity of apperception as an explanation for how a world is represented to us, for how successive perceptions are rendered intellectually coherent. Instead of some a priori principle of unity, Schopenhauer sees the will alone as holding all representations together. In one sense, of course, the will *is* Schopenhauer’s principle of unification; but he situates us in a world that no longer has any significant common ground with Kant’s. If for Kant the synthetic unity of apperception gave an apodictic or absolute character

127. *Ibid.*, p. 139.

128. *Ibid.*

129. See my discussion of this issue in relation to the rise of physiological optics in the 1830s and 1840s in *Techniques of the Observer*, pp. 67–96.

130. Ernst Cassirer, *Das Erkenntnisproblem in der Philosophie und der Wissenschaft der neueren Zeit*, vol. 3 (1907; Darmstadt: Wissenschaftliche Buchgesellschaft, 1971), pp. 413–414.

to perceptual experience, the will in Schopenhauer coincides with a primal absence of any reason, logic, or meaning behind appearances. In Terry Eagleton's words, "The Schopenhauerian will, as a form of purposiveness without purpose, is in this sense a savage travesty of the Kantian aesthetic."¹³¹ The chaotic successiveness of perception is determined only by the unmotivated and blind movement of will. For most individual subjects, the will was directly experienced as one's own body; that is, the will's most immediate objectified form was the instinctual desiring economy of one's physical existence.¹³² Thus our relationship to the sensory manifold of the world is determined not by the structuring imposition of a priori forms but through the fathomless vagaries of aimless unconscious, often primarily sexual, drives and forces. Yet it was this understanding which impelled Schopenhauer to postulate the possibility of a looking, a purified perception that would be a suspension from time and the body's economy, which was to become a mirage of modernism by the end of the century.

In this light it is possible to position Schopenhauer not only as the overturning of a Kantian model of synthesis, but as an early and decisive nineteenth-century assault on the very possibility of a philosophy of consciousness. Distraction and forgetfulness (suggesting sublimation and repression) became for Schopenhauer powerful components within the fluid economy of psychic experience. All of the mental states (sleep, trance, fainting, daydream, dissociation) that classical thought had marginalized or excluded from its theories of knowledge now took center stage as parts of psychological accounts of normative subjectivity. Within a more generalized historical frame, we see the disintegration of the epistemological tradition running from Descartes to Kant for which consciousness or the cogito is the ground of all knowledge and certitude. For it is only when consciousness ceases to have an unquestioned foundational priority that attention emerges

131. Terry Eagleton, *The Ideology of the Aesthetic* (Oxford: Blackwell, 1990), p. 159. He continues: "With Schopenhauer, desire has become the protagonist of the human theater, and human subjects themselves its mere obedient bearers or underlings. This is not only because of the emergence of a social order in which, in the form of commonplace possessive individualism, appetite is now becoming the order of the day, the ruling ideology and dominant social practice; it is more because of the perceived *infinity* of desire in a social order where the only end of accumulation is to accumulate afresh. In a traumatic collapse of teleology, desire comes to seem independent of any particular ends, or at least grotesquely disproportionate to them." See the related account in Rudiger Safranski, *Schopenhauer and the Wild Years of Philosophy*, trans. Ewald Osers (Cambridge: Harvard University Press, 1990), pp. 191–222. Also valuable is the chapter on Schopenhauer in Michel Henry, *The Genealogy of Psychoanalysis*, trans. Douglas Brick (Stanford: Stanford University Press, 1993), pp. 164–203.

132. "My teaching asserts that the whole body is the will itself, exhibiting itself in the perception of the brain. . . . The whole body is and remains the presentation of the will in perception." Schopenhauer, *The World as Will and Representation*, vol. 2, p. 250.

as a problem—when a subject ceases to be synonymous with a consciousness that is essentially self-present to itself, when there is no longer an inevitable congruence between subjectivity and a thinking “I.” Freud, for example, had duly noted the huge significance of Henry Maudsley’s 1868 declaration “It is a truth that cannot be too distinctly borne in mind that consciousness is not co-extensive with mind.”¹³³ Obviously consciousness continues to be a central issue in many places, but the emphasis on attentiveness as one of its constitutive features is a sign of its increasingly provisional and problematic character.

By the end of the nineteenth century, the temporality that had been a problem for Schopenhauer was an integral part of a wide range of psychological and epistemological positions.¹³⁴ Wilhelm Dilthey put forth his notion of subjective experience as “a continuous stream” even as he affirmed the unity of consciousness. In language that has not fully broken with Herbartian psychomechanics and yet is also precociously evocative of cinematic dissolve, Dilthey writes that “the course of psychic life as given in the flow of time can only manifest one relative representation as it disappears and another relative representation as it begins to appear.” Dilthey’s dilemma, which many others faced as well, was how to account for both the impalpability of lived subjective experience and the individual as an active and creative subject within objective historical processes. Dilthey’s gamble was that there was a nexus at which those two categories of temporality intersected: “Let us say that in every present, there occurs in consciousness a synthesis whose elements point both backwards and forwards to an objective nexus that encompasses what we know and do.”¹³⁵

Dilthey also pondered how the selective and delimited nature of attention was related to the relative narrowness of consciousness. He was firmly opposed to the notion of the unconscious, and sought to bypass the problems this dualism posed for his free subject of lived knowledge and experience. Instead, he imagined consciousness as an immense terrain that was illuminated only in very small areas by the beam of attention. Many representations, psychic acts, and processes

133. Sigmund Freud, *The Interpretation of Dreams*, trans. James Strachey (New York: Avon, 1965), p. 650, note 1. The quote is from Henry Maudsley, *The Physiology and Pathology of the Mind*, 2d ed. (London: Macmillan, 1868).

134. For example, even a figure as central to the institutionalization of scientific psychology as G. Stanley Hall expressed, as late as 1902, his admiration for and indebtedness to Schopenhauer. See Dorothy Ross, *G. Stanley Hall: The Psychologist as Prophet* (Chicago: University of Chicago Press, 1972), p. 264.

135. Wilhelm Dilthey, *Introduction to the Human Sciences* (1883), ed. Rudolf A. Makkreel and Frithjof Rodi (Princeton: Princeton University Press, 1989), pp. 317–318.

“are conscious but not attended to, noticed or possessed in reflexive awareness.” He describes attention in terms of a “quantum of energy” that diminishes the scope of attentive awareness the more intently it is deployed. “If I am looking out the window and perceive a landscape, the light of consciousness may well distribute itself evenly over the entire landscape. But as soon as I try to apprehend a single tree or even a branch in greater detail, the consciousness which I direct toward the rest of the landscape diminishes.”¹³⁶ In the mid-1880s, Dilthey was, like many others, reacting against associationist explanations of mental and perceptual processes which posited the objects of consciousness or perception as fixed quantities or representations.¹³⁷ Attention became part of his reconceptualization of psychic experience in terms of new “life-categories” in which the temporal continuum of individual existence and the historicity of human culture were intertwined processes. “The entire *acquired nexus* of psychic life . . . transforms and shapes those perceptions, representations, and states on which the attention is directly focused, and which thus engage our consciousness most strongly. . . . Thus there is a constant interaction between the self and the milieu of external reality in which the self is placed, and our life consists of the interaction.”¹³⁸

In the work of Charles S. Peirce attention occupies a pivotal position. In 1868 he sweepingly declared: “Sensation and the power of abstraction or attention may be regarded as, in one sense, the sole constituents of all thought.” But he severs attention from any notion implying a fullness of presence or direct perception of the world. For Peirce, attention is an act of selection, but not in the sense of a gaze singling out an object for contemplation or scrutiny. “By the force of attention, an emphasis is put on one of the objective elements of consciousness.”¹³⁹ But it has no connection with Peirce’s regulative concept of Firstness, which designates the idea of absolute presence and self-immediacy, preceding all synthesis and

136. *Ibid.*, pp. 313–314.

137. On the larger rejection of associationism in the 1880s, see Maurice Mandelbaum, *History, Man, and Reason: A Study in Nineteenth Century Thought* (Baltimore: Johns Hopkins University Press, 1971), pp. 218–222.

138. Wilhelm Dilthey, “The Imagination of the Poet” (1887), in Dilthey, *Poetry and Experience*, vol. 5 of his *Selected Works*, ed. Rudolf A. Makkreel and Frithjof Rodi (Princeton: Princeton University Press, 1985), p. 72. “But as perceptions or representations appear in the real nexus of psychic life they are permeated, colored, and enlivened by feelings. The distribution of feelings, interests, and the way they influence our attentiveness, bring about, in conjunction with other causes, the appearance, the gradual unfolding, and the disappearance of representations. Efforts of attention—which derive from feelings, but are forms of volitional activity—impart an impulsive energy to individual images or permit them to fade away again. In the real psyche, therefore, every representation is a *process*” (p. 68).

139. Peirce, “Some Consequences of Four Incapacities,” pp. 61–62.

differentiation. For Peirce human perception was intrinsically incapable of such a state of newness, of nonreferentiality. A truly immediate perception for Peirce would be of some timeless, unchanging condition. Instead, attention was irrevocably constituted in time, in what he called Secondness. “Attention is a matter of continuous quantity; for continuous quantity, so far as we know it, reduces itself in the last analysis to time. . . . Attention is the power by which thought at one time is connected with and made to relate to thought at another time.” Attention, he contends, is an act of induction. In the context of my argument, the importance of Peirce’s position is its anti-opticality, its rejection of the visual models at the core of traditional epistemological thought.¹⁴⁰

It was another maverick philosopher, William James, who put forward one of the most influential dynamic models of mental activity, using the notion of a “stream of thought.” Working with the more act-oriented term “thought” instead of “consciousness,” James uses the image of the stream to describe the fundamentally *transitive* nature of subjective experience—a perpetually changing but continuous flow of images, sensations, thought fragments, bodily awareness, memories, desires—which he sets against older and even contemporary accounts for which consciousness has discrete contents and elements. James modifies the Baudelairean image into “a kaleidoscope revolving at a uniform rate” as a way of describing the brain “as an organ whose internal equilibrium is always in a state of change, the changes affecting every part.”¹⁴¹ At the same time it is also important to understand how the stream is James’s figuration of an impossible harmony: that is, in which the unstable, kinetic, and fragmented character of modern subjective life is at once acknowledged but reconceived as fundamentally continuous and as that which endows subjectivity with an irreducible unity, even in the face of all the dissociations, anesthetics, hallucinations, and multiple selves that James had studied so thoroughly. The idea of the stream of thought is central in his rejection of spatial or classical scenic models of the mind in favor of temporal ones. “No

140. Richard Rorty discusses the pragmatist critique of metaphors of vision, correspondence, picturing, and the spectator theory of knowledge in his *Consequences of Pragmatism* (Minneapolis: University of Minnesota Press, 1982), pp. 160–166.

141. “We believe the brain to be an organ whose internal equilibrium is always in a state of change,—the changes affecting every part. The pulses of change are doubtless more violent in one place than in another, their rhythm more rapid at this time than at that. As in a kaleidoscope revolving at a uniform rate, although the figures are always rearranging themselves, there are instants during which the transformation seems minute and interstitial and almost absent, followed by others when it shoots with magical rapidity, relatively stable forms thus alternating with forms we should not distinguish if seen again; so in the brain the perpetual rearrangement must result in some forms of tension lingering relatively long, whilst others simply come and pass.” James, *Principles of Psychology*, vol. 1, p. 246.

doubt," he writes in a well-known passage, "it is often convenient to formulate the mental facts in an atomistic sort of way, and to treat the higher states of consciousness as if they were all built out of unchanging simple ideas. . . . But . . . there is nothing in nature to answer to our words. A permanently existing 'idea' or 'Vorstellung' which makes its appearance before the footlights of consciousness at periodic intervals, is as mythological an entity as the Jack of Spades."¹⁴² Despite the singularity of much of James's work and the residual temptation to associate his "stream of thought" with what was once thought of as a Joycean-Bergsonian modernism, it is important to see how his work lies adjacent to a larger institutional field in which scientific psychology generally was abandoning *elemental* conceptions of consciousness in favor of operational or functional models.¹⁴³ At the same time, techniques of suggestion in early forms of modern advertising effectively coincided with this model of psychic behavior and aesthetic creativity, as Franco Moretti has shown: "Here we find precisely the randomness, discontinuity, uncontrollability and depth of the stream of consciousness. . . . The associations of stream of consciousness are by no means 'free.' They have a cause, a driving force, which is *outside* the individual consciousness. . . . The absence of internal order and of hierarchies indicates its reproduction of a form of consciousness which is subjugated to the principle of the *equivalence of commodities*."¹⁴⁴

James is of particular interest for his emphasis on the primacy of the "stream" and at the same time for situating attention, that which figuratively freezes the stream, as an indispensable activity "without which experience is an utter chaos."¹⁴⁵ Attention for James is inseparable from the possibility of a cognitive and perceptual immediacy in which the self ceases to be separate from a world of objects, even if a stabilization of those objects can never occur.¹⁴⁶ It becomes the

142. *Ibid.*, p. 236.

143. For example, even someone as rooted within an older associationist psychology as Théodule Ribot used language that loosely overlaps with James's, in describing the ordinary mechanism of mental life as "a perpetual coming and going of inward events, in a marching by of sensations, feelings, ideas, and images. . . . Properly speaking, it is not, as frequently has been said, a chain, a series, but it is rather an irradiation in various directions and through various strata; a mobile aggregate which is being incessantly formed, unformed, and reformed." Ribot, *The Psychology of Attention*, p. 3. On Ribot and the academic foundations of scientific psychology in France, see John L. Brooks, "Philosophy and Psychology at the Sorbonne 1885–1913," *Journal of the History of Ideas* 29 (April 1993), pp. 123–145.

144. Franco Moretti, *Signs Taken for Wonders: Essays in the Sociology of Literary Forms*, rev. ed., trans. Susan Fischer et al. (London: Verso, 1988), p. 197.

145. James, *Principles of Psychology*, vol. 1, p. 402.

146. Attention as a guarantor of cognitive immediacy would be part of what James Livingston sees as a larger preoccupation of pragmatism in the late nineteenth century: "Its theoreticians do not believe that thoughts and things inhabit different ontological orders: they do not acknowledge an external or

necessary means for managing the irreducible plurality of experience, and as such it is a reconciliatory attempt to think simultaneously in terms of fluidity and immobilization. That is, James acknowledges the impossibility of epistemological certainties but is quick to head off the wider and disturbing implications which that acceptance entails.¹⁴⁷ Attention has a particular ethical significance: “The practical and theoretical life of the whole species, as well as of individual beings, results from the selection which the habitual direction of their attention involves. . . . Each of us literally *chooses*, by his ways of attending to things, what sort of a universe he shall appear to himself to inhabit.”¹⁴⁸ At any given moment the mind is a potentially paralyzing welter “of simultaneous possibilities. Consciousness consists in . . . the selection of some, and the suppression of the rest by the reinforcing and inhibiting agency of attention.”¹⁴⁹ He compares the observer to an artist: confronted with “the primordial chaos of sensations,” we extricate our subjective worlds, selecting and rejecting, as a sculptor works on a block of stone. But this sense of the aesthetic dimension of the attentive self is elided with ethical responsibilities as well. For James the fact that we all seem to inhabit a common perceptual world is due not to the a priori structure of our minds, but rather to the overlapping common choices made by a historically evolving human community of free individuals.¹⁵⁰ What we each attend to in the world is not identical but effectively similar and

natural realm of objects, of things-in-themselves, which is ultimately impervious to, or fundamentally different than, thought or mind or consciousness. Accordingly they escape the structure of meanings built around modern subjectivity, which presupposes the self's separation or cognitive distance from this reified realm of objects.” Livingston, *Pragmatism and the Political Economy of Cultural Revolution, 1850–1940* (Chapel Hill: University of North Carolina Press, 1994), p. 214.

147. Cornel West outlines the mediating dimension of James's thought, and in particular how his work sought to lessen the shock of recent scientific and psychological work for an American middle-class readership. See West, *The American Evasion of Philosophy: A Genealogy of Pragmatism* (Madison: University of Wisconsin Press, 1989), p. 55.

148. James, *Principles of Psychology*, vol. 1, p. 424. It should be at least noted that one of James's most celebrated undergraduate students completed and published an idiosyncratic research project on attention under his supervision. See Gertrude Stein, “Cultivated Motor Automatism: A Study of Character in Its Relation to Attention,” *Psychological Review* 5, no. 3 (May 1898), pp. 295–306.

149. James, *Principles of Psychology*, vol. 1, p. 288. See the intellectual genealogy in Henri Ey, *Consciousness: A Phenomenological Study of Being Conscious and Becoming Conscious*, trans. John Flodstrom (Bloomington: Indiana University Press, 1978), p. 19: “Attention is that force through which Maine de Biran, William James, Bergson, Janet, etc. have defined psychical energy and dynamism. Attention to life, interest, concentration, intentional orientation, and motivation all express the tension toward a desired goal, proposed or prescribed, which constitutes the ‘intentional kernel’ or seat of a ‘state of consciousness.’”

150. “But all the while the world we feel and live in will be that which our ancestors and we, by slowly cumulative strokes of choice, have extricated out of this, like sculptors, by simply rejecting certain parts of the given stuff. . . . In my mind and in your mind the rejected portions and the selected portions are to a great extent the same. The human race as a whole largely agrees to what it shall notice and name, and what not.” James, *Principles of Psychology*, vol. 1, p. 289. The interrelation between the aesthetic

purposive enough to produce a common realm of communication, interaction, and value.¹⁵¹

But James's emphasis on the creative and pragmatic dimension of the attentiveness of any given autonomous subject coincides with the historical emergence of increasingly powerful technologies and institutions that would determine and enforce *externally* the objects of attention for mass populations.¹⁵² The influential William B. Carpenter (whose work James knew well) had sketched, in the 1870s, the outlines of this disciplinary framework in which attention is conceived as an element of subjectivity to be externally shaped and controlled: "It is the aim of the Teacher to fix the attention of the Pupil upon objects which may have in themselves little or no attraction for it. . . . The habit of attention, at first purely automatic, gradually becomes, by judicious training, in great degree amenable to the Will of the Teacher, who encourages it by the suggestion of appropriate motives, whilst taking care not to overstrain the child's mind by too long dwelling upon one object."¹⁵³ The possibility of this kind of learned behavior paralleled many other new social forms of self-regulation and self-control in the nineteenth century.

James is representative of much of the discourse on attention in that he attempted to salvage some relatively stable notion of consciousness and some form of a distinct subject/object relation, but he tended to describe only a fleeting

and the ethical as a component of "the self-choosing infinite self" is discussed in terms of nineteenth-century postromanticism in Charles Taylor, *Sources of the Self: The Making of the Modern Identity* (Cambridge: Harvard University Press, 1989), pp. 449–455.

151. James's position here was taken up and developed by many in the next generation of "functionalists." James R. Angell, a pupil of both James and Dewey, insisted, "In all forms of attention, then, we find selective activity going on. Selection always implies a purposive, forward-looking type of action, and this is precisely what attention is in all its forms. It stands for the fact that the organism is teleological in its very constitution, that is to say, the organism contains within itself certain *ends* to be attained in the course of development by adjustive activities. . . . Attention is always an effort to conquer our own impulses, or thoughts, in the interest of the end to which we are attempting to attend." Angell, *Psychology: An Introductory Study of the Structure and Function of Human Consciousness* (New York: Henry Holt, 1904), pp. 75–76.

152. Ross Posnock discusses James's anxiety about the rise of positivist sociology, scientific management, and, in general, methods of social control. James "is responding to another, unspoken, but more ominous source: the growth of a professionally administered social order. The coercive character of modernity is reflected in the ascendancy of social control as the governing concern of the social sciences. . . . The Jamesian pluralist diving back into the flux seems as far from Taylorized efficiency as possible." Posnock, *The Trial of Curiosity: Henry James, William James and the Challenge of Modernity* (Oxford: Oxford University Press, 1991), pp. 110–116.

153. Carpenter, *Principles of Mental Physiology* (1886), pp. 134–135. Many of the pedagogical and disciplinary imperatives in Carpenter's work remained effective for over four decades, as can be seen, for example, in the work of James's Harvard colleague and rival, Hugo Munsterberg, *Psychology and the Teacher* (New York: D. Appleton, 1909), esp. pp. 157–171.

immobilization of a “subject effect” and an ephemeral congealing of a changing sensory manifold into a cohesive real world. Ribot acutely observed that attention “is an exceptional, abnormal state, which cannot last a long time, for the reason that it is in contradiction to the basic condition of psychic life, namely change.”¹⁵⁴ Helmholtz earlier had similarly noted: “An equilibrium of the attention, persistent for any length of time, is under no circumstances attainable. The natural tendency of attention when left to itself is to wander to ever new things.”¹⁵⁵ By the 1880s such an understanding had become pervasive, and the remarks of psychologist and aesthetician Theodor Lipps are typical: “Again and again, it is a matter of experience that a part we intend to hold fast, and which we even think we are holding in the grip of attention, will slip away from our grasp, with something else taking its place. Thus we succeed with difficulty or not at all, in the certain apprehension or isolation of a perceptual content.”¹⁵⁶ Attention, then, was what prevented our perception from being an incoherent flood of sensations, yet research showed it to be an undependable defense against such disorder. It was an indispensable component of the “normal” and “rational” subject of late nineteenth-century industrial society, yet had a disturbing proximity to “pathological” and “irrational” effects. In spite of the importance of attention in the organization and modernization of production and consumption, most studies implied that attention rendered perceptual experience into something labile, continually undergoing change, and finally dissipative.¹⁵⁷ From the classical model of a mental stabilization of perceptions into a fixed mold, attention in the nineteenth century effectively became a

154. Ribot, *The Psychology of Attention*, p. 2.

155. Hermann Helmholtz, quoted in James, *Principles of Psychology*, vol. 1, p. 422. See also Marillier, “Remarques sur le mecanisme de l’attention,” pp. 569–570.

156. Theodor Lipps, *Psychological Studies* (1885), trans. Herbert C. Sanborn (Baltimore: Williams and Wilkins, 1926), p. 89.

157. “The successive movement of attention over a number of objects appears accordingly to be a *periodic* process, made up of a number of separate acts of apperception following one another. Such a *periodic rise and fall of attention* can under favorable conditions be directly demonstrated. . . . Thus, if we allow a weak continuous impression to act on a sense organ and remove as far as possible all other stimuli, it will be observed when the attention is concentrated upon this impression that at certain generally irregular intervals, the impression becomes for a short time indistinct, or even appears to fade out entirely, only to reappear the next moment.” Wilhelm Wundt, *Outlines of Psychology* (1893), 4th rev. ed., trans. Charles H. Judd (Leipzig: Engelmann, 1902), p. 233; emphasis in original. Angelo Mosso noted that “attention involves modifications of a complex nature” involving periodic oscillations. “Experiments have shown that attention is not a continuous but an intermittent process proceeding almost by bounds.” *Fatigue*, pp. 183–184. Attention is described as a periodic, wavelike form in Thaddeus Bolton, “Rhythm,” *American Journal of Psychology* 6, no. 2 (January 1894), pp. 145–238. An account of attention also could have certain affinities with Hegel’s description of “sense-certainty” as a self-canceling form of apprehension, as a rhythm of “appearing” and “melting away.” See G. W. F. Hegel, *The Phenomenology of Mind*, trans. J. B. Baillie (New York: Harper and Row, 1967), pp. 149–161.

continuum of variation, a temporal modulation, and it was repeatedly described as having a rhythmic or wavelike character.¹⁵⁸ Though it appeared to hold the possibility of building up stable and orderly (though not necessarily truthful) cognitions, it also contained within itself uncontrollable forces which would put that organized world in jeopardy. Within the general epistemological crisis of the late nineteenth century, attention became a makeshift and inadequate simulation of an Archimedean point of stability from which consciousness could know the world. Rather than perceptual fixity and the certainty of presence, it opened onto flux and absence within which subject and object had a scattered, provisional existence.¹⁵⁹



Perhaps nowhere else in the late nineteenth century is the ambivalent status of attention as visible as in the social phenomenon of hypnosis. Hypnotism, for several decades, uneasily stood as an extreme model of a technology of attention. But even as it seemed to offer new possibilities of clinical power and medical benefits, it disclosed the unsettling outlines of a subject whose uncertain makeup could evade both intellectual and institutional mastery.¹⁶⁰ Demonstrating so dramatically the precariousness and malleability of what had been thought of as consciousness, hypnosis posed an unprecedented challenge to the separability of psychological, physiological, and social factors.¹⁶¹ As experimentation of many kinds in the late nineteenth century seemed to show, the border between a focused normative attentiveness and a hypnotic trance was indistinct. Hypnosis (a word that denotes both a psychical state and specific practices for inducing such

158. On the distinction between mold and modulation see Gilbert Simondon, *L'individu et sa genèse psycho-biologique* (Paris: Presses universitaires de France, 1964), pp. 39–44. See the related discussion in Gilles Deleuze, *The Fold: Leibniz and the Baroque*, trans. Tom Conley (Minneapolis: University of Minnesota Press, 1993), pp. 19–21.

159. For Henry Adams, in the late 1890s, the modern subject was one whom “normal thought was dispersion, sleep, dream, inconsequence; the simultaneous action of different thought-centers without central control.” The human mind, he wrote, passed “half its known life in the mental chaos of sleep; victim even when awake, to its own ill-adjustment, to disease, to age, to external suggestion, to nature’s compulsion; doubting its sensations, and, in the last resort, trusting only to instruments and averages.” Henry Adams, *The Education of Henry Adams* (Boston: Houghton Mifflin, 1973), pp. 434, 460.

160. The pervasive optimism about hypnosis as a cure-all is evident in a typical medical handbook on the subject: “I rejoice that I have lived to see the triumph of chemistry, of surgery, of physiological and pathological research; but research on hypnotism promises discoveries greater than all these; those which will reveal the laws which govern and control the actions, feelings, and thoughts.” James R. Cocke, *Hypnotism: How It Is Done, Its Uses and Dangers* (Boston: Arena, 1894), p. 93.

161. To the question of what hypnosis is, Isabelle Stengers replies: “Essentially we know nothing about it. . . . We still speak of hypnosis without being able to distinguish between ‘music hall’ hypnosis, the different forms of ritually organized trance, the murderous hypnosis associated with Hitler or Khomeini, the stupefied hypnosis surely induced by television, and hypnosis done under experimental protocol.” Stengers, “The Deceptions of Power: Psychoanalysis and Hypnosis,” *Sub-Stance* 62–63 (1990), pp. 81–91.

a state) was often described as an intense refocusing and narrowing of attention, accompanied by inhibition of motor responses. Research, beginning with James Braid in the 1840s and continuing with Auguste Liebeault in the 1860s, explored the apparent and paradoxical proximity of both hypnosis and attention to sleep.¹⁶² Disturbing questions were implicit in such observations: how could attention, which was posed as a bulwark against dissociation, a guarantee of the cohesiveness of consciousness and its relation to the world, a tool of productivity, be so immediately adjacent to states that implied a loss of self-possession, of conscious affect and agency?

By the late nineteenth century, hypnosis was generally determined to be at one extreme of a continuum of attention, involving an intensification of focal concentration with a relative suspension of peripheral awareness. G. Stanley Hall, writing in 1883, is typical in his assertion that “most of the phenomena to which we give the name of hypnotism” are due not to mesmeric forces “but only to an unusual degree of ‘concentration of Attention,’ variously directed by suggestions of many kinds.”¹⁶³ It was understood that what one perceives under hypnosis is lucid and detailed but that the range of awareness is extremely narrow. In fact, the most common techniques for inducing a hypnotic trance were forms of focalization, that is, of concentrating one’s attention on some specific object, often a bright, luminous point, but sometimes an idea or simply the rhythm of one’s own breathing or heartbeat. Attention was thus shown to be the gateway to some vaguely understood but qualitatively different state from what had been understood as consciousness.¹⁶⁴ And the well-known debates of the 1880s about what this enigmatic state denoted: was it, as J.-M. Charcot and his followers at the Salpêtrière believed, a sign of some underlying somatic disorder, or was it, as Hippolyte Bernheim and others insisted, an exaggeration of a fully normal state of suggestibility?

The work of Liebeault, which was responsible for the formation of the so-called school of Nancy in the 1880s, postulated attention as the most important and creative element of psychic life; it was a mobile dynamic force responsible

162. James Braid, *Neurypnology or the Rationale of Nervous Sleep* (London: J. Churchill, 1843); Auguste Liebeault, *Le sommeil provoqué et les états analogues* (Paris: Doin, 1889); and Charles Richet, “Du somnambulisme provoqué,” *Journal de l’anatomie et de la physiologie normales et pathologiques* 11 (1875), pp. 348–378.

163. Hall, “Reaction-Time and Attention in the Hypnotic State,” p. 170. Hall emphasizes the idea of an uncertain continuum of attentive states: “Upon the Attention-hypothesis a great number of neural disorders are seen to be only exaggerations of states familiar to every normal mind.”

164. See, for example, the survey of techniques of hypnotic induction in Albert Moll, *Hypnotism* (1889), new trans. (New York: Scribner’s, 1899), pp. 31–64.



Demonstration of Bernheim's method of hypnotic induction, 1890s.

for all perception and motor activity. Liebeault believed that hypnotic induction produced a sleeplike state in which attention was immobilized or isolated. The state he called *somnambulisme provoqué* was for him a drastic reorientation of attentiveness, which could be produced by a set of relatively simple techniques. Bernheim's redeployment of Liebeault's work into a more systematic clinical practice included a method of induction called "fixed attention," in which sustained looking at a single point or object produced a dramatic reorganization of consciousness. The enduring importance of the Nancy school was to have situated hypnotic phenomena within the terrain of *normal* perception, rather than as symptoms of illness or weakness. Bernheim would repeatedly make this general claim: "I have endeavored to show that hypnotism does not really create a new condition: there is nothing in induced sleep which may not occur in the waking condition, in a rudimentary degree in many cases, but in some to an equal extent."¹⁶⁵

Hypnosis also made clear that attentive states could be delineated in terms of absorption, dissociation, and suggestibility. The link between attention and dissociation is particularly significant in that it provides a way of understanding how

165. Hippolyte Bernheim, *Hypnosis and Suggestion in Psychotherapy* (1884), trans. Christian Herter (New York: Aronson, 1973), p. 179. Compare *ibid.*, pp. 149–150: "The hypnotic condition is not an abnormal one, it does not create new functions nor extraordinary phenomena; it develops those which are produced in the waking condition. . . . Perhaps in reality there are neither one nor two states of consciousness, but infinitely varying states. All degrees of variation may exist between the perfect waking condition, and the condition of perfect concentration which constitutes somnambulism."

attentiveness can be, in the words of a recent researcher, a matter of the “mental separation of components of experience that would otherwise be processed together.”¹⁶⁶ This might involve discontinuities of various kinds between motor, sensory, and psychological experiences. William James was one of many in the 1880s who investigated the dissociations that could occur in either absorbed or hypnotic states, in which two distinct mental processes could occur simultaneously.¹⁶⁷ Perhaps most significantly, research in this area, beginning as early as Mesmer and continuing throughout the nineteenth century, disclosed that even as hypnosis involved a narrowing of attention, it paradoxically also enabled subjects to *expand* their awareness, in effect to see and remember *more* (as modern-day police departments and others have learned).¹⁶⁸ It revealed itself in many instances to be a means of memory recovery so efficient that it is no wonder it so scandalized psychoanalysis, burdened with its more glacial therapeutic time frame.

As a historical phenomenon, hypnosis also has to be seen within a larger field of rationalizing processes. Just as photographic and cinematic innovations in the 1880s and 1890s defined the terms of an automation of perception, hypnosis too (in spite of the paradoxes it revealed) was a technology that offered at least the fantasy of rendering behavior both automatic and predictable.¹⁶⁹ Even though

166. David Spiegel, “Neurophysiological Correlates of Hypnosis and Dissociation,” *Journal of Neuropsychiatry and Clinical Neuroscience* 3 (1991), p. 440: “Hypnosis is at one extreme of the continuum of attention, involving an enhancement in focal concentration with a relative suspension of peripheral awareness. Hypnotic concentration is like looking through a telephoto lens in a camera. What one sees is detailed, but the range of vision is narrow. . . . A main component of the hypnotic state is suggestibility, which is heightened responsiveness to social cues, leading to an enhanced tendency to comply with hypnotic instructions. This represents not a loss of will but rather a suspension of critical judgment because of the intense absorption of the hypnotic state. Hypnotic instructions are acted upon automatically and often are mistakenly perceived as internally generated.”

167. See Eugene Taylor, *William James on Exceptional Mental States: The 1896 Lowell Lectures* (Amherst: University of Massachusetts Press, 1983), pp. 15–34; and John F. Kihlstrom and Kevin M. McConkey, “William James and Hypnosis: A Centennial Reflection,” *Psychological Science* 1, no. 3 (May 1990), pp. 174–178.

168. For example, Schelling, around 1812, wrote about how “Mesmeric sleep” constituted a breakdown of the unity of wakeful states, releasing the possibility of “the development of visionary talent in general.” He speculated on the continuity and “gradations” between apparently distinct states: “For many reasons, it seems to me as if the so-called mesmeric sleep has been distinguished much too sharply from ordinary sleep.” Schelling, *The Ages of the World*, trans. Frederick deWolfe Bolman (New York: Columbia University Press, 1942), p. 181.

169. See, for example, the account of hypnosis as a practical social technology of attention in H. G. Wells, *When the Sleeper Wakes* (1899). In this novel set in the twenty-second century, “the practical applications of psychology were now in general use” deriving from the work of “Fechner, Liebeault, William James” and others. “Little children of the labouring class, so soon as they were of sufficient age to be hypnotized, were thus converted into beautifully punctual and trustworthy machine minds. . . . A sort of psychic surgery was, in fact, in general use.” *Three Prophetic Novels*, ed. E. F. Bleiler (New York: Dover, 1960), p. 124.



Sven Richard Bergh, *Hypnotic Seance*, 1887.

the hypnotic trance was a profoundly ambiguous state, it became a powerful image of a docility produced according to specific psycho-medical procedures. But by the early twentieth century hypnosis abruptly disappeared from the mainstream of institutional practice and research. The anxious renunciation of hypnosis by Freud, Bernheim, and others was only one of the more widely known signs of this shift.¹⁷⁰ There was an astonishing cultural reversal from the great heyday of hypnosis in the late 1880s, when across Europe and North America it seemed a therapy that promised unlimited benefits, to the turn of the century, when it had become an embarrassment to its former advocates.¹⁷¹ The *Revue de l'Hypnotisme*

170. On Freud's abandonment of hypnotic technique, see Leon Chertok and Isabelle Stengers, *A Critique of Psychoanalytic Reason: Hypnosis as a Scientific Problem from Lavoisier to Lacan*, trans. Martha Noel Evans (Stanford: Stanford University Press, 1992), esp. pp. 36–45.

171. Pierre Janet (1859–1947) was one of the few French psychologists who unapologetically continued to include hypnosis at the heart of his therapeutic project well into the twentieth century. Today one frequently encounters a refusal, which amounts to historical falsification, to acknowledge that hypnosis in the late 1880s and early 1890s was normative institutional science. Thus, for example, the inaccurate statement by historian Mark S. Micale that “ages of high scientism have typically spawned counter-cultures: mesmerism during the late Enlightenment, faith-healing and hypnotism at the turn of the last century, our own New Age psychologies and alternative medicines,” in his “Strange Signs of the Times,” *Times Literary Supplement*, May 16, 1997, pp. 6–7. This currently fashionable opposition of high science and peripheral pseudo-science imposes a dubious model on a historical period when

experimental, founded in 1886, had by the early twentieth century changed its name to *Revue de Psychothérapie et de Psychologie appliquée*.

Hypnosis so powerfully implied excessive possibilities of perceptual and cognitive control, regardless of whether these were empirically proven, that it became incompatible with humanist assumptions about the autonomous and voluntaristic character of human subjectivity (even though psychoanalysis was to have its own incompatibilities with such assumptions).¹⁷² Hypnosis and suggestion were soon derided as practices directed toward automatic processes (those inferior, more instinctual, and continuous with animality) rather than a rational procedure eliciting the patient's conscious participation and will power. Bernheim's vivid characterization of hypnosis as "mental decapitation" was typical of images around which such anxieties later developed.¹⁷³ There were also numerous, highly publicized court cases (most of them clearly fraudulent) concerning individuals who claimed to have been coerced by hypnosis into sexual or criminal behavior against their will.¹⁷⁴ It was not that inquiry and research on the possible control of human subjects ceased, in fact far from it; it was that ideologically these areas could not be acknowledged as a constitutive part of the human sciences. The disavowal of

such clear-cut distinctions did not exist. For example, the postulation of the existence of the luminiferous ether in physics had a complex and shifting relation of mutual exchange with a huge range of ideas about "spiritism" and "action at a distance."

172. Modern suspicion of hypnosis begins with Hegel's reflections on Mesmer and "magnetic states," which Hegel saw as an illness: "But if my psychical life separates itself from my intellectual consciousness and takes over its function, I forfeit my freedom which is rooted in that consciousness, I lose the ability to protect myself from an alien power, in fact become subjected to it. . . . In this magical relationship, the main point is that one individual acts on another whose will is *weaker* and *less independent*. Therefore very powerful natures exercise the greatest power over weak ones, a power often so irresistible that the latter can be put into a magnetic trance by the former whether they wish it or not." *Hegel's Philosophy of Mind*, pp. 116–117. Mesmerism, for Hegel, served as a figure for a specific moment of *self-differentiation* in a larger account of the development of consciousness.

173. The position of hypnosis within a popular imagination is suggested in Strindberg's 1887 play *The Father*, about power relations within a disintegrating marriage, in which the husband reproaches his spouse: "If I was awake, you could hypnotize me so that I could neither see nor hear, but only obey; you could give me a raw potato and convince me that it was a peach; you could compel me to admire your most childish remark as if it were a flash of genius; you could have led me into crime, and even into petty meanness." Strindberg, *Three Plays*, trans. Peter Watts (Harmondsworth: Penguin, 1958), pp. 58–59. There was an extensive popular literature that presented disturbing images of hypnosis, including the anti-Semitic *Trilby* (New York: Harper and Brothers, 1894) by the British writer and illustrator George Du Maurier. In France such works included William Mintorn, *La somnambule* (Paris: Ghio, 1880); the pseudonymous novella by psychologist Charles Richet, published as Charles Epeyre, "Soeur Marthe," *Revue des Deux Mondes* 93 (May 15, 1889), pp. 384–431; and the well-known short story "La Horla" (1886) by Guy de Maupassant. Hypnotism is a tool both of the forces of evil and of scientific rationality in Bram Stoker's *Dracula* (1897).

174. See, for example, the discussion in J. Liegeois, *De la suggestion et du somnambulisme dans leurs rapports avec la jurisprudence et la médecine légale* (Paris: Doin, 1889); and Georges Gilles de la Tourette, *L'hypnotisme et les états analogues au point de vue medico-legal* (Paris: E. Plon, 1887).

hypnosis occurred in spite of the enormous amount of clinical evidence indicating that hypnotized subjects, in an essential way, preserved their freedom. Since Freud's reversal, hypnosis has continued to be a culturally disturbing phenomenon precisely because it resists scientific mastery or rationalization, rather than, as was often asserted, because it was "an assault on the patient's dignity."¹⁷⁵ As a model of power relations, hypnosis is irredeemably naive, and it became increasingly useless and parodic as it overlapped with the early cinematic images of Caligari and Mabuse and then with the alleged capabilities of real-life despots. In fact, most trance states are deeply irreconcilable with the functioning of productive or regulating institutions. But the very preposterousness of the hypnotic model, in its hyperbolic form, resulted in prohibiting or at least discouraging analysis of other less extreme kinds of power relations and effects (including the problem of attention), of stigmatizing critical positions which imply that volitional human action can in some way be modified by external forces.¹⁷⁶

Television especially, in a variety of forms, emerged as the most pervasive and efficient system for the management of attention, and it has become so fully integrated into social and subjective life that certain kinds of statements about television (for example, about addiction, habit, persuasion, and control) are in a sense unspeakable, effectively excluded from public discourse. To speak of contemporary collective subjects in terms of effects of passivity and influence is still generally anathema.¹⁷⁷ As Paul Virilio has noted, even to raise the possibility of "modes of

175. Stengers, "The Deceptions of Power," pp. 81–91: "Suggestion frightens judges when they don't want to be instruments of *undisguised* power. Hypnosis not only disappointed Freud, but all who turned their attention to it in order to judge it, to measure its effects, to identify its invariables. We don't know much about hypnosis or suggestion because they point to something against which the power of judgment must define itself." See also the discussion of hypnosis in Julian Jaynes's unjustly proscribed *The Origins of Consciousness in the Breakdown of the Bicameral Mind* (Boston: Houghton Mifflin, 1976), p. 379: "For hypnosis is the black sheep of the family of problems which constitute psychology. It wanders in and out of carnivals and clinics and village halls like an unwanted anomaly. It never seems to straighten up and resolve itself into the firmer proprieties of scientific theory. Indeed, its very possibility seems a denial of our immediate ideas about conscious self-control on the one hand, and our scientific idea about personality on the other. Yet, it should be conspicuous that any theory of consciousness and its origin, if it is to be responsible, *must* face the difficulty of this deviant type of behavioral control."

176. Though obviously dated now, see the valuable overview of twentieth-century attempts at developing behavior management technologies in Perry London, *Behavior Control* (New York: Harper and Row, 1969).

177. On the importance of low-level effects of suggestion and influence in contemporary global culture, see Daniel Bounoux, "L'impense de la communication," in Daniel Bounoux, ed., *La suggestion: hypnose, influence, transe* (Paris: Colloque de Cerisy/Les Empêcheurs de Penser en Rond, 1991), pp. 297–314. He outlines the role that suggestion plays in a society of communication, "including effects of fashion, mimesis, mass psychology, media-related contagions, and influences of all kinds," and how these "oblige us to revise our notions of individuality and of consciousness."

mass manipulation” is not simply tactless and indiscreet, it is “to violate a state secret of the same order as a military secret.”¹⁷⁸ There is usually a tacit a priori conviction that television viewers constitute a hypothetical community of rational and volitional human subjects. The contrary position, that human subjects have determinate psychophysiological capacities and functions that might be susceptible to technological management, has been the underpinning of institutional strategies and practices (regardless of the relative effectiveness of such strategies) for over a hundred years, even as it must be disavowed by so-called critics of those same institutions.¹⁷⁹



If attention has persisted as a problem over the last century, I do not mean to imply that arrangements of power or control (with which attention is ambivalently intertwined) have in any sense been invariable or enduring. On the contrary, one of the reasons attention continues to be an issue is the way in which shifting organizations of power and changing models of subjectification have, throughout the twentieth century, demanded reciprocal refashionings of attentive behavior. A task outside the scope of this book would be to chart the mutating relationship of attention with various systems, institutions, and machinic relations, and to identify with

178. Paul Virilio, *The Vision Machine* (1988), trans. Julie Rose (Bloomington: Indiana University Press, 1994), p. 23.

179. Whether or not attention actually can be controlled or managed, it is important to recognize the massive material and intellectual resources that have been deployed on the *assumption* that it can be controlled for specific ends. Beginning as early as the 1880s, empirical studies of attention were used to modify arrangements of labor in workplaces as a way of maximizing productivity, something that has continued into present-day electronic work environments. By the very early twentieth century the management of consumption became equally important, and a whole arena of psychological testing opened up in order to determine methods for effectively controlling attention in advertising. By the teens an enormous number of studies had been done in both Europe and North America. See, for example, Walter D. Scott, *The Psychology of Advertising* (Boston: Small, Maynard & Co, 1908); Edward K. Strong, “The Relative Merit of Advertisements: A Psychological and Statistical Study,” *Archives of Psychology* 17 (July 1911); H. F. Adams, “Adequacy of the Laboratory Test in Advertising,” *Psychological Review* 22, no. 5 (September 1915), 403–422; “The Class Experiment in Psychology with Advertisements as Materials,” *Journal of Educational Psychology* 3 (1912), pp. 1–17; Howard K. Nixon, *Attention and Interest in Advertising* (New York: Archives of Psychology, 1924). For typical mid-twentieth-century work, see the chapter “Capturing Attention” in Darrell Lucas and Stuart H. Britt, *Advertising Psychology and Research* (New York: McGraw-Hill, 1950). Today such research continues unabated on a vast scale, working, for example, with detailed monitoring of electrical activity in the brain in relation to attention. See, for example, M. Rothschild et al., “EEG Activity and the Processing of Television Commercials,” *Communication Research* 13 (1986), pp. 182–219. At the same time the use of psychochemicals to enhance attentiveness is being studied in many different ways. See, for example, B. S. Oken et al., “Pharmacologically Induced Changes in Arousal: Effects on Behavioral and Electrophysiologic Measures of Alertness and Attention,” *Electroencephalography and Clinical Neurophysiology* 95, no. 5 (November 1995), pp. 359–371. See also the range of work represented in Patricia Cafferata and Alice Tybout, eds., *Cognitive and Affective Response to Advertising* (Lexington, Mass.: Lexington Books, 1989). These are a few of the literally thousands of related studies published every year.

specificity meaningful continuities between the late nineteenth century and our time. This would also involve examining the widely different ways in which attention has been both a strategy of control and a locus of resistance and drift, or more often an amalgam of both. The present work attempts to consider some of the elements that make up the early part of that larger history, which we all have a stake in understanding.

I have already suggested the ways in which attention took shape as an object in relation to the concrete organization and management of education and labor. In this sense it is inseparable from the operation of what Foucault has described as “disciplinary” institutions, but as an inversion of his panoptic model in which the subject is *an object* of attention and surveillance. Hence the modern notion of attention is a sign of reconfigurations of those disciplinary mechanisms. If disciplinary society was originally constituted around procedures through which the body was literally confined, physically isolated and regimented, or set in place at work, Foucault makes clear that these were but the first relatively crude experiments in an ongoing process of perfecting and refining such mechanisms. By the early twentieth century, the attentive subject is part of an *internalization* of disciplinary imperatives in which individuals are made more directly responsible for their own efficient or profitable utilization within various social arrangements. And certainly the attempts in the late nineteenth century to determine the limits of a “normative” attentiveness were part of this transformation.

But if attention can be situated within Foucault’s particular account of Western modernization, I will also link it to Guy Debord’s theorization of a “society of the spectacle.”¹⁸⁰ Debord’s work and Foucault’s might seem remote from each other, and certainly the two stood for very different kinds of thinking, of critique, and of political intervention.¹⁸¹ Despite Foucault’s specific dismissal of the idea of spectacle as relevant to considerations of modern society, there are some important points of overlap between the models of a society of discipline and of spectacle. Debord’s work is often associated with the more facile meanings of his book’s title, disregarding an essential characterization of the society of the spectacle: rather than emphasizing the effects of mass media and its visual imagery, Debord

180. It should be remembered that Guy Debord describes spectacle with the phrase *comportement hypnotique* (trancelike behavior) in the opening pages of his *Societe du spectacle*: see *The Society of the Spectacle* (1967), trans. Donald Nicholson-Smith (New York: Zone Books, 1994), p. 17.

181. Even though Debord’s *Society of the Spectacle* was one the most influential challenges in the 1960s to established Marxist positions, it nonetheless operates, at least implicitly, within a Hegelian intellectual terrain to which Foucault was adamantly hostile.

insists that spectacle is (in a loose rephrasing of Tonnies's *Gesellschaft*) the development of a technology of separation. It is the inevitable consequence of capitalism's "restructuring of society without community."¹⁸² Debord's account of spectacle as multiple strategies of isolation parallels those outlined by Foucault in *Discipline and Punish*: the production of docile subjects, or more specifically the reduction of the body as a political force. And Max Weber's identification of "the inner isolation of the individual" as a foundation of capitalist modernity stands behind both of these thinkers.¹⁸³ Also, Debord and Foucault both outline *diffuse* mechanisms of power, through which imperatives of normalization or conformity permeate most layers of social activity and become subjectively internalized. It is in this sense that the management of attention, whether through early mass-cultural forms in the late nineteenth century or later through the television set or the computer monitor (at least in their overwhelmingly pervasive forms), has little to do with the visual contents of these screens and far more with a larger strategy of the individual.¹⁸⁴ Spectacle is not primarily concerned with a *looking at* images but rather with the construction of conditions that individuate, immobilize, and separate subjects, even within a world in which mobility and circulation are ubiquitous.¹⁸⁵ In this way attention becomes key to the operation of noncoercive forms of power. This is why it is not inappropriate to conflate seemingly different optical or technological objects: they are similarly about arrangements of bodies in space, techniques of isolation, cellularization, and above all separation. Spectacle is not

182. Debord, *Society of the Spectacle*, pp. 121, 137. The necessity of destroying the possibility of community was part of the technology of attention already in the early twentieth century: "But various factors in rearranging their establishments according to the principles of scientific management have changed the position of the workmen so that conversations become more difficult or impossible. The result reported seems to be everywhere a significant increase of production. The individual concentrates his mind on the task with an intensity which seems beyond his reach as long as the inner attitude is adjusted to social contact." Hugo Munsterberg, *Psychological and Industrial Efficiency* (Boston: Houghton Mifflin, 1913), p. 209.

183. Max Weber, *The Protestant Ethic and the Spirit of Capitalism* (1904), trans. Talcott Parsons (New York: Scribner's, 1958), p. 108. The work of Henri Lefebvre was directly significant for Debord: "Here we witness the conflict between a certain 'atomization' of life (unilaterally denounced a hundred times over) and an overorganization which hems life in, and doubtless requires it to be atomized as a necessary precondition. *The socialization of society* goes on unabated. As the networks of relations and communications get more dense, more effective, so at the same time the individual consciousness becomes increasingly isolated and unaware of 'others.' That is the level on which the contradiction operates." Lefebvre, *Introduction to Modernity* (1962), trans. John Moore (London: Verso, 1995), p. 190.

184. Raymond Williams situates television within a technological and economic logic of "mobile privatization," in his *Television: Technology and Cultural Form*, p. 26.

185. See the discussion of Debord and issues of distraction, distance, and separation in Hal Foster, *The Return of the Real* (Cambridge: MIT Press, 1996), pp. 218–220.

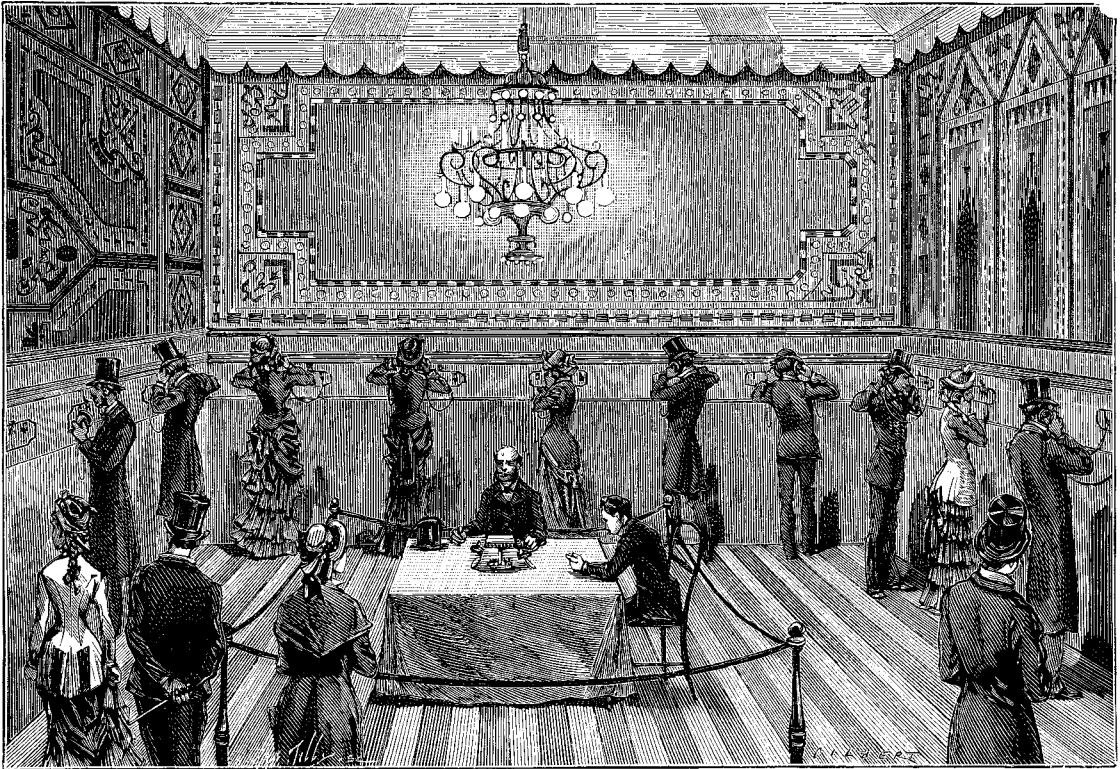

Technologies of separation. Telephonic listening room at the Exposition d'Electricite, Paris, 1881.

an optics of power but an architecture. Television and the personal computer, even as they are now converging toward a single machinic functioning, are antinomadic procedures that fix and *striate*. They are methods for the management of attention that use partitioning and sedentarization, rendering bodies controllable and useful simultaneously, even as they simulate the illusion of choices and “interactivity.”

This is certainly not to minimize the need for historically analyzing specific and local interfaces of humans and machines. One of the most compelling assessments of the various human-machine composites is in the work of Gilles Deleuze and Felix Guattari. They distinguish several dominant historical models of how human beings have interfaced or been “subjected to machines or machinic systems.” Industrial capitalism, beginning in the nineteenth century, was one phase in which a human operator was linked to a machine as an exterior object. More recently, however, with cybernetic and informational machines, “the relation

between human and machine is based on internal, mutual communication, and no longer on usage or action.”¹⁸⁶ Deleuze (by himself) has proposed that during the last two decades there has been a modification of Foucault’s disciplinary societies into “societies of control,” in which the combination of a global market, information technology, and the irresistible imperative of “communication” produces continuous and unbounded effects of control.¹⁸⁷ I would stress that, however we label and characterize such historical shifts or social transformations within the last century, attention has continued to be integral to the subjects produced for a wide range of socio-technical machines, even as it simultaneously continues to be a potential site of breakdown or crisis in terms of the efficient operation of these machines. It is becoming clearer that a concurrence of panoptic techniques and attentive imperatives now functions reciprocally in many social locations.¹⁸⁸ The video display terminal, in particular, can stand for the effective fusion of surveillance and spectacle, as the screen is both the object of attention and yet capable of monitoring, recording, and cross-referencing attentive behavior for purposes of productivity or even, through the tracking of eye movement, for the accumulation of data on the specific paths, durations, and fixations of visual interest in relation to a flow of images and information. Attentive behavior in front of all kinds of screens is increasingly part of a continuous process of feedback and adjustment within what Foucault calls a “network of permanent observation.”¹⁸⁹

186. Gilles Deleuze and Felix Guattari, *A Thousand Plateaus: Capitalism and Schizophrenia*, trans. Brian Massumi (Minneapolis: University of Minnesota Press, 1987), pp. 456–459: “Modern power is not at all reducible to the classical alternative ‘repression or ideology’ but implies processes of normalization, modulation, modeling, and information that bear on language, perception, desire, movement, etc. and which proceed by way of microassemblages.” For a related discussion of problems of subjectification in contemporary capitalism, see Michel Feher and Eric Alliez, “The Luster of Capital,” *Zone* 1–2 (1985), pp. 314–359.

187. See Deleuze’s essays “Control and Becoming” and “Postscript on Control Societies,” in his *Negotiations, 1972–1990*, trans. Martin Joughin (New York: Columbia University Press, 1995), pp. 169–182. His model of a “control society” has affinities with Guy Debord’s own revision of his original 1967 typologies of totalitarian “concentrated” and capitalist-consumer “diffuse” societies of spectacle into a single global “integrated” society of the spectacle, which he outlined in his *Comments on the Society of the Spectacle*, trans. Malcolm Imrie (London: Verso, 1990).

188. See the discussion of attention in Marie Winn, *The Plug-In Drug: Television, Children and the Family*, rev. ed. (New York: Penguin, 1985), p. 64: “Of course there are variations in the attention-getting and attention-sustaining powers of television images, many of which depend on such factors as the amount of movement present on the screen at any given moment, and the velocity of change from image to image. It is a bit chilling to consider that the producers of the most influential program for pre-school children, ‘Sesame Street,’ employed modern technology in the form of a ‘distractor’ machine to test each segment of their program to ensure that it would capture and hold the child’s attention to the highest degree possible.”

189. Michel Foucault, *Discipline and Punish* (1975), trans. Alan Sheridan (New York: Pantheon, 1977), p. 295. See D. N. Rodowick, “Reading the Figural,” *Camera Obscura* 24 (September 1990), p. 35: “The

At the same time, for every mutation in the construction of attentiveness there are parallel shifts in the shape of inattention, distraction, and states of “absent-mindedness.” New thresholds continually emerge at which an institutionally competent attentiveness veers into something vagrant, unfocused, something folded back against itself.¹⁹⁰ Because so many forms of a disciplinary attentiveness, especially since the early twentieth century, have entailed cognitively “processing” a stream of heterogeneous stimuli (whether film, radio, television, or cyberspace), the kind of swerves into inattentiveness increasingly have produced alternate experiences of dissociation, of temporalities that are not only dissimilar to but also fundamentally incompatible with capitalist patterns of flow and obsolescence. The daydream, which is an integral part of a continuum of attention, has always been a crucial but indeterminate part of the politics of everyday life. However, as Christian Metz and others have argued, in the twentieth century both film and television have entered into a “functional competition” with daydream.¹⁹¹ Though its history will never be formally written, the daydream is nonetheless a domain of resistance internal to any system of routinization or coercion. Similarly, institutional models of attention based on imperatives of recognition, identity, and stabilization are never fully separate from nomadic models of attention that generate novelty, difference, and instability.

However, one feature of many contemporary technological arrangements is the imposition of a permanent low-level attentiveness that is maintained to varying degrees throughout large expanses of waking life. The later nineteenth century saw the onset of a relentless colonization of “free” or leisure time. Initially this was relatively scattered and partial in its effects, allowing oscillations between spectacular attentiveness and the free play of subjective absorptions. But at the end of the twentieth century, the loosely connected machinic network for electronic work,

goals of interactive computing that are in the vanguard of research on new electronic media, while genuinely utopian, must nonetheless be questioned. For the dream of the individual’s absolute control over information is simultaneously the potentiality for absolute surveillance and the reification of private experience.”

190. Using the example of television, Felix Guattari suggests some of the heterogeneity of an attentive subjectivity: “When I watch television, I exist at the intersection 1) of a perpetual fascination provoked by the screen’s luminous animation which borders on the hypnotic 2) of a captive relation with the narrative content of the program, associated with a lateral awareness of surrounding events—water boiling on the stove, a child’s cry, the telephone . . . 3) of a world of fantasms occupying my daydreams. My feeling of personal identity is thus pulled in different directions. How can I maintain a relative sense of unicity, despite the diversity of components of subjectivation that pass through me? It’s a question of the refrain that fixes me in front of the screen.” Guattari, *Chaosmos: An Ethico-Aesthetic Paradigm*, trans. Paul Bains and Julian Pefanis (Bloomington: Indiana University Press, 1995), pp. 16–17.

191. Christian Metz, *The Imaginary Signifier*, trans. Celia Britton et al. (Bloomington: Indiana University Press, 1982), pp. 135–137.

communication, and consumption has not only demolished what little had remained of the distinction between leisure and labor but has come, in large arenas of Western social life, to determine how temporality is inhabited. Information and telematic systems simulate the possibility of meanderings and drift, but in fact they constitute modes of sedentarization, of separation in which the reception of stimuli and the standardization of response produce an unprecedented mixture of diffuse attentiveness and quasi-automatism, which can be maintained for remarkably long periods of time.¹⁹² In these technological environments, it's questionable whether it is even meaningful to distinguish between conscious attention to one's actions and mechanical autoregulated patterns. Writing in the 1960s, Arthur Koestler described the "dimming of awareness" produced by repetitive experiences within homogeneous sensory milieus: "Automatised routines are self-regulating in the sense that their strategy is automatically guided by feedbacks from their environments, without the necessity of referring decisions to higher levels. They operate by closed feedback loops."¹⁹³ But what once might have been called reverie now most often takes place aligned with preset rhythms, images, speeds, and circuits that reinforce the irrelevance and dereliction of whatever is not compatible with their formats. Beyond the limits of the present study is the question of how and whether creative modes of trance, inattention, daydream, and fixation can flourish within the interstices of these circuits. It is particularly important now to determine what creative possibilities can be generated amid new technological forms of boredom.¹⁹⁴

192. For discussion of recent research on attention and automatic behavior, see Larry L. Jacoby et al., "Lectures for a Layperson: Methods for Revealing Unconscious Process," in Robert F. Bornstein and Thane S. Pittman, eds., *Perception without Awareness: Cognitive, Clinical and Social Perspectives* (New York: Guilford, 1992), pp. 81–122. The authors discuss automaticity as "performance under conditions of divided attention," in which automatic behavior "is not a characteristic of stimulus driven processing but, rather, is an emergent property of the exercise of specific skills in an environment." See also Cathleen M. Moore and Howard Egeth, "Perception without Awareness: Evidence of Grouping under Conditions of Inattention," *Journal of Experimental Psychology: Human Perception and Performance* 23, no. 2 (April 1997), pp. 339–352; and Daniel Kahneman and Anne Treisman, "Changing Views of Attention and Automaticity," in Parasuraman and Davies, eds., *Varieties of Attention*, pp. 29–62.

193. Arthur Koestler, *The Ghost in the Machine* (New York: Macmillan, 1967), p. 207. There were, for example, attempts to evaluate the automatic behavior that accompanied the installation of the interstate highway system after World War II, when monotonous and uninterrupted driving conditions produced trancelike states in drivers but did not interfere with their ability to perform various mechanical tasks. See Griffith W. Williams, "Highway Hypnosis: An Hypothesis," in Ronald E. Shor and Martin T. Orne, eds., *The Nature of Hypnosis: Selected Basic Readings* (New York: Holt, Rhinehart, 1965), pp. 482–490.

194. On the historical construction of modern boredom, see Patrice Petro, "After Shock/Between Boredom and History," in Patrice Petro, ed., *Fugitive Images: From Photography to Video* (Bloomington: Indiana University Press, 1995), pp. 265–284. See also Joseph Brodsky, "In Praise of Boredom," in his *On Grief and Reason* (New York: Farrar Straus, 1995), pp. 104–113.

Having thus briefly touched on some of the stakes in contemporary constructions of attentive perception, I want to return to the late nineteenth century and begin a much more local consideration of the paradoxes implicit in a newly modernized attentiveness. Working through a very different set of objects from those of this chapter, I will trace how normative conceptions of attention intersected with problems of cognitive and perceptual *synthesis*. At the same time I will examine how notions of subjective attentiveness first began to overlap with the idea of *automatic* behavior and functioning, in terms of the perceptual breakdowns or dissociations that coincide with sustained or fixed attentive experiences. The issue of the automatic is crucial within the specifically modern problem of attention: it poses the notion of absorbed states that are no longer related to an *interiorization* of the subject, to an intensification of a sense of selfhood. The inwardness of what Hegel called romanticism is not so much exceeded here as it is paradoxically turned inside out, into a condition of externalization: attention as a depthless interface simulates and displaces what once might have been autonomous states of self-reflection or a *sens intime*. The logic of spectacle prescribes the production of separate, isolated, but not introspective individuals.

TWO
1879: Unbinding Vision

With a glance I shall gather up the virginal absence scattered through this solitude and steal away with it; just as, in memory of a special site, we pick one of those magical, still unopened water-lilies which suddenly springs up there and enclose, in their deep white, a nameless nothingness made of unbroken reveries, of happiness never to be—made of my breathing, now, as it stops for fear that she may show herself.

—Stéphane Mallarmé,
“The White Water-Lily”

Two or three times already, when everyone else was getting ready to leave, we had seen a man of large stature, very muscular, with regular features and a grizzled beard, come in and sit down at a table, where his pensive gaze remained fixed with concentrated attention upon the void. One evening, on asking our landlord who this obscure, solitary and belated diner was, “What!” he exclaimed, “do you mean to say you don’t know the famous painter Elstir?”

—Marcel Proust,
Within a Budding Grove



Edouard Manet, The Balcony, 1868.

The disengagement of perception from a model of interiority is an essential part of the work of Edouard Manet, and is decisively evident in his *The Balcony* from 1868. Although this painting slightly precedes the period which is the focus of this book, it discloses some of the important reconfigurations of the status of the observer that had occurred by the middle of the nineteenth century. But it is more than that, and if this enigmatic painting can be deemed profoundly “modern,” it is so by its very superficiality, where this term has to do not with surface or shallowness but with *externality*.¹ The balcony figuratively repositions the observing subject outside of the terms of a classical system of vision, collapsing the mutual necessity of a subjective interiority on one hand and the objectivity of an exterior world on the other. Its optical system is no longer one in which the world is present to the subject in relations of reflection, correspondence, or representation. The eye ceases to be a window, with transparent and transitive properties. Instead, the quiet circulation of receptive anticipation in this epiphanic painting is inseparable from the possibility, the dream of a new and modern *immediacy*. The opening of the shutters, the moving out to the balcony from the shadows of the interior discloses the limpid freshness of a vision that might directly grasp the world; it is the claiming of a site from which the world, in its becoming modern, could be created anew to these three observers by virtue of its unmediated, unobstructed self-presence. And the three figures compose themselves with faint traces of awkwardness, of an etiquette tested, as when one receives well-recommended but unknown guests for the first time.

When Mallarmé referred to “Manet’s newly awakened eye,” he was not invoking the innocence of some natural original state of vision (and implicitly of the self), but an eye rendered oblivious to, though not necessarily free of, the weight of a historical past and all its codes.² The open shutters of Manet’s balcony divulge a world in which artifice has preempted the memory of the “natural” and vision is fully attuned to the subtleties and textures of this perpetually modernized present.³

1. This is also how Manet’s *Balcony* can be distinguished from the often associated *Majas on a Balcony* of Goya, which maintained a space of interiority and concealment in spite of the seemingly related architectural setting. Its resistance to externality is what constitutes its romanticism.

2. Stéphane Mallarmé, *Oeuvres complètes* (Paris: Gallimard, 1945), p. 532.

3. The celebrated use of green in this canvas maps out a new exercise of perceptual discrimination; but it is hardly a single green, as many have indifferently assumed, but a range of distinct hues and surfaces: the oxidized copper green of the metallic railing, the hard aqua green (with much white pigment added) of the industrial house paint on the shutters, the quasi-Kelly green ribbon around the neck of the seated woman, and the silky water-repellent emerald green fabric of the umbrella. The virtuosity of this palette, and its corresponding chromatic sensibility to the luminous wavelengths of a new technological lifeworld, become a sign for the artificiality and again superficiality of the work, of

But such an immediacy will remain in Manet's work only a virtuality, as it would also for Mallarmé. Of course, in a local historical sense, the balcony stands between two faces of the newly rebuilt Paris of Haussmann: the domestic interior of the new apartment block and the building's exterior face onto the world of the boulevard. Certainly Haussmannization, as an early instance of what would become the unremitting sequence of destruction and modernization of urban space, is a crucial component of the regime of perceptual adaptability that I mentioned earlier. Baudelaire, around 1860, keenly understood the accelerated temporality at work: "A city's pattern changes, alas, more swiftly than the human heart."⁴ The painting, then, incarnates the attentiveness created within these new terms: an attention that in seeking the presence of the immediate is instead deflected by the absence and cancellation implicit in processes of capitalist rationalization, of which Haussmann's urban renewal would be an inescapable example.

The world now is something more evanescent, its substantiality irrevocably discredited. At the same time, the painting dramatizes the evaporation of a cohesive world that is perceived collectively. But for Manet this loss is nothing to be lamented: as much as in any of his multifigured paintings, the three noncommunicating gazes here determine a "perspectival" world in Nietzsche's sense of that word. In this finely assembled architecture of solitude and separation are three serenely fragile spaces of a newly modern individual autonomy, rather than anything we could easily label anomie or alienation. One intuits the noncoincidence of one's inherence in the world with anyone else's; and this is inseparable from a sovereign awareness of the intimate singularity and creative mutability of the self.⁵ This was an understanding, an affirmative figuration Manet could not maintain for very long, and fifteen years later the deflections and divisions of *Bar at the Folies-Bergère* will constitute a very different model of the social and cognitive isolation of a perceiving subject.

its remoteness from all of the premodern resonances (vegetative or otherwise) of green. The potted plant at the lower left is simply a marginal and domesticated remnant of a displaced field of "natural" objects and perceptions. The modulations of the color green here are fully derived from the technical sphere of mass production and materials: an optical environment built up out of the colors of textiles, dyes, chemicals, metals.

4. Charles Baudelaire, "Le cygne," in *Oeuvres complètes* (Paris: Gallimard, 1961), p. 81. See the brief discussion of this painting in Christoph Asendorf, *Batteries of Life: On the History of Things and Their Perception in Modernity*, trans. Don Renau (Berkeley: University of California Press, 1993), pp. 78–79.

5. See the discussion of autonomy and intrasubjectivity in the context of nineteenth-century aesthetic production and post-Kantian epistemology in Rose Subotnik, *Developing Variations: Style and Ideology in Western Music* (Minneapolis: University of Minnesota Press, 1991), pp. 57–83.

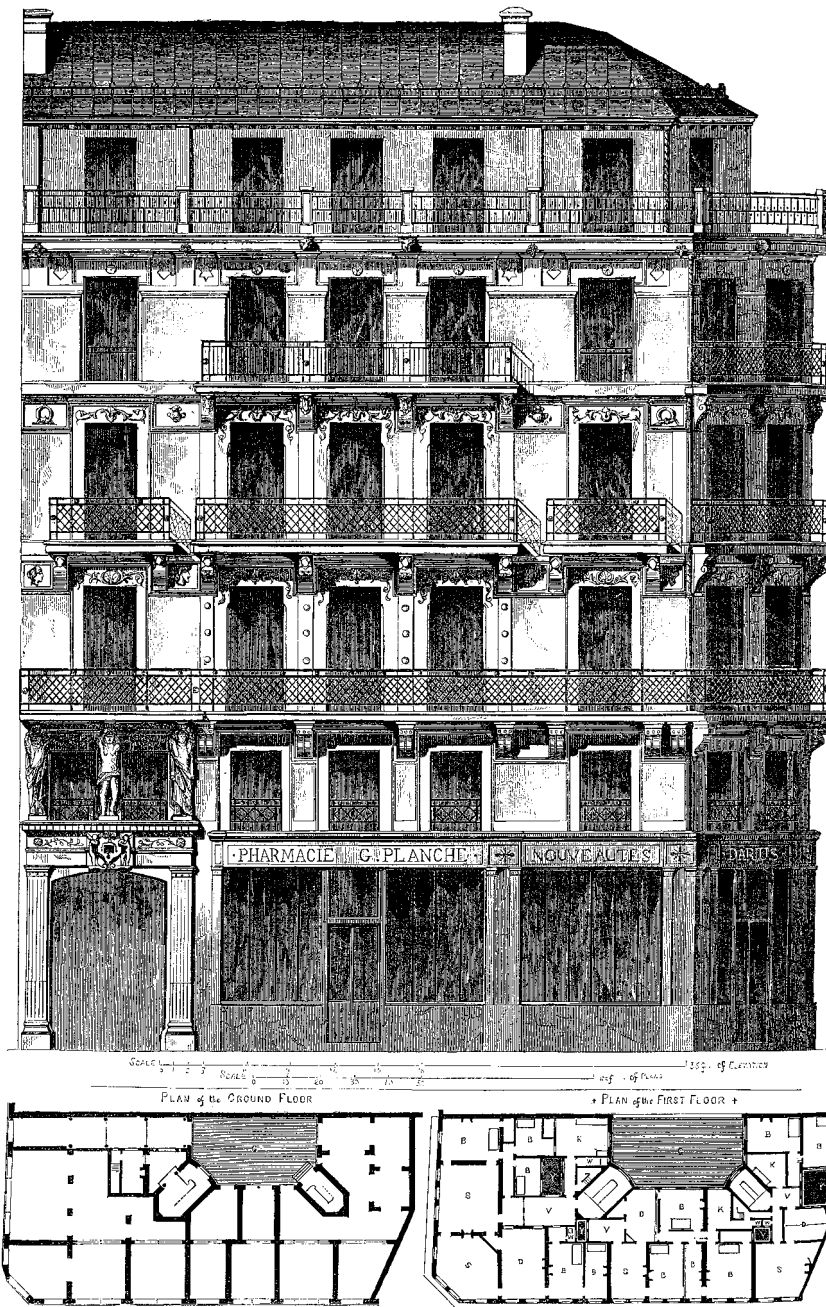

Facade and plans of Second Empire apartment building, Paris, late 1850s.

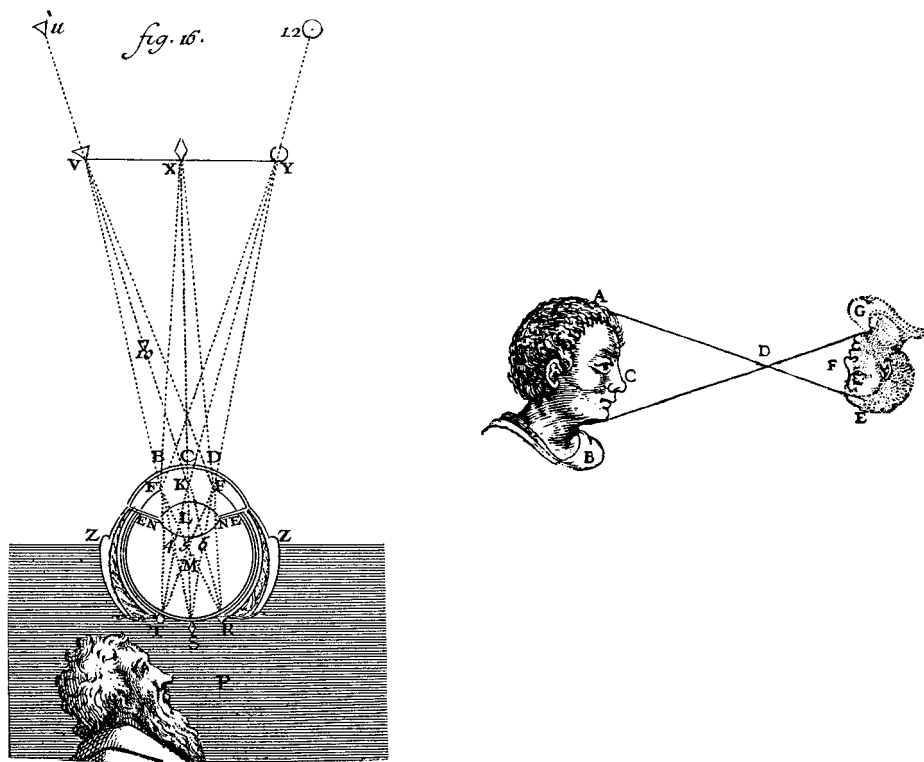

Diagrams from early eighteenth-century edition of Descartes's *La dioptrique*.

One of the conspicuous features of *The Balcony* is the geometry of the metal railing that screens the lower part of the picture and that has an enormous structural importance in the composition as a whole. But the decorative linear patterns of the railing are of special interest here: on a plane parallel with the picture surface, they not only represent a spare industrial design but also resemble elementary diagrams of a classical optical system, familiar generic diagrams that could have been seen in any encyclopedia, or in any standard edition of Descartes. In this sense the central disk of the railing pattern would correspond to the monocular eye in Descartes's illustration, with a triangular (or conical) beam radiating out from that eye. But of course it is not that simple: if one extends that reading, the central disk takes on a Janus-like reversibility, with an optical beam extending from two opposite sides, like the psychological ambivalence of the figures, situated uncertainly between interiority and exteriority. This pattern also suggests two

binocular gazes meeting at a central point of convergence, where the top and bottom corners of the rectangle outline the position of eyes from which a reversed cone of vision is resolved at the central disk. This reading would outline, perhaps with ironic wit, precisely the ideal of vision as *reflexive*, as the property of a subject figured as a geometric point, which is disrupted by the ambiguity and disorganization of the painting's intersubjective relations.⁶ But at the same time the railing can be read as a confirmation of the insularity and noncongruity of the three visual fields implied by the human figures: for example, the gaze of the seated woman (the artist Berthe Morisot) is abstractly extended by the two parallel diagonal lines of the railing leading down to the lower left, which loosely indicate the direction of her gaze. Or the two parallel diagonals that lead to the lower right of the painting loosely correspond to the visual orientation of the central male figure. Thus it would be possible to see each unit of the railing with its central disk as a self-enclosed modular unit of visibility and at the same time to see the parallel diagonals as a system that traverses and interlaces that other model of self-reflexive autonomy. Yet, having proposed these possibilities, I would argue that the importance of this linear system is finally its unintelligibility, its suggestion of the futility and even absurdity of a rationalizable spatial account of vision. For if the geometries of the railing subsist as a map of vision, it is only as a demonstration of its tangled paradoxes, its reversibilities, exchangabilities, its extraction from the coherent order of geometrical optics. In Lacan's words, "There is not a single one of the divisions, a single one of the double sides that the function of vision presents that is not manifested to us as a labyrinth."⁷

Manet's painting takes us outside of a stable circuit of visibility to an arrangement in which neither eye nor objects in the world can be understood in terms of fixed positions and identities. The threshold here is not just between the balcony and the world but between an attentiveness seeking to grasp and inhabit the palpable immediacy of a modernized present and the dissolution of that attentiveness into an unbounded self-absorption.⁸ In this sense the nebulous obscurity of the

6. See Jacques Lacan's consequential distinction between vision, as a point-to-point optical system, and the gaze, inseparable from a desiring subject, which can never coincide with the geometric relations constituting that formal model of vision, in *The Four Fundamental Concepts of Psycho-analysis*, trans. Alan Sheridan (New York: Norton, 1978), pp. 67–122.

7. *Ibid.*, p. 93.

8. See Lawrence Kramer's discussion of "impossible objects" of attention in nineteenth-century art and literature, in *Music as Cultural Practice, 1800–1900* (Berkeley: University of California Press, 1990), pp. 87–101: "In the broadest terms, impossible objects are products of an epistemological/

space behind the figures is as much a part of their psychological elusiveness as is the uncertain content of the exterior in front of them. It is an early outline of what Simmel several decades later would pose as the incommensurability of objective and subjective culture, but here that split is not presented in terms of shock, overstimulation, and indifferent reserve. Rather, *The Balcony* delineates a new psychic permeability and mobility, where attentiveness becomes a fluctuating membrane, a delicately tuned pattern of folding and unfolding onto the world. The contents of the painting amplify that sense of a repetitive and nonlinear temporality: the vertical blinds like the literal shutter of a camera or eye, the fan and umbrella, and even the blossoms of the potted flowers, all imply a lived rhythm of opening and closing. Manet reimagines the social dispersion of modernity here as a hushed acquiescence to this impassive autosufficiency of the individual observer. Perhaps it is this very indetermination, the unmeasurable but tangible pulse of a suspended moment hovering between a functional operation of vision and the atemporal undulations of reverie, that led Georges Bataille to his extravagant assessment of the painting: “Then, as we begin to take it in, we scented the deep secret behind this picture—the beauty and intensity of life itself.”⁹

In the 1870s, Manet would elaborate on many of the epistemological and representational problems implicit in *The Balcony*. One of his most important concerns in this decade was to explore the creative possibilities derivable from a deepening understanding of the disintegrative limits of vision. According to a number of critics, one of the decisive formal achievements of Manet’s work of the 1870s was his tentative splitting apart of figural, representational facts on one hand and the facts of autonomous pictorial substance on the other, and that in his advanced canvases this splitting approached a breaking point of “formlessness.”¹⁰ Between 1876 and 1879, for example in *Before the Mirror*, *Self-Portrait with Palette*, *Portrait of George Moore*, or *The Reader*, he dances near the edges of this possible rupture. Painted with an openness and looseness, a virtuoso recklessness, but also a deeply confident *inattention* to the object and its coherence, we see in such images what Bataille referred to as Manet’s “supreme indifference.”¹¹

topographical discourse in which human subjectivity ceases to be a common field and becomes, instead, a secret recess. No longer a shared sameness, the self is an essential difference . . . the self is constantly threatened with separation from the outer world” (p. 88).

9. Georges Bataille, *Manet*, trans. Austryn Wainhouse and James Emmons (New York: Skira, n.d.), p. 85.

10. See, for example, Jean Clay, “Ointments, Makeup, Pollen,” *October* 27 (Winter 1983), pp. 3–44.

11. Bataille, *Manet*, p. 82.



Edouard Manet, The Reader, 1877.



Edouard Manet, Self-Portrait with Palette, 1877.

However, I've chosen to look at a quite different kind of painting from Manet's work of the late 1870s, *In the Conservatory* from 1879. This work was regarded at the time, and has continued to be seen, as a retreat from features of his more "ambitious" style. Exhibited at the Salon of 1879, it provoked some telling responses by mainstream critics. Jules-Antoine Castagnary in the newspaper *Siecle* wrote with a tone of mock surprise: "But what is this? Faces and hands more carefully drawn than usual: is Manet making concessions to the public?"¹² Other reviews noted the relative "care" or "ability" with which Manet had executed this work. And the avalanche of recent Manet scholarship has given this painting relatively little notice, thereby perpetuating the evaluation of it as somehow conservative.¹³ It is usually classed as one of Manet's representations of fashionable contemporary life, of *la vie moderne*, and an image that would hardly seem to anticipate the formal audacity of *Bar at the Folies-Bergere* of 1881. Some commentators have pointed to "the more conservative technique," and the "more contained outlines" of the figures in contrast to Manet's other work of the same years.¹⁴ But I don't think that it explains much to say that the work is simply a shift back to a more conventional naturalism or that, stung by a number of Salon rejections in the 1870s, he modified his style in the hope of wider critical acceptance, for these do not address the strangeness of this painting. Michael Fried incisively characterized *In the Conservatory* as "an almost excessively 'finished' painting."¹⁵ It is in this sense of an *excessive*, overcompensating finish that I see the work as an anxious

12. Jules-Antoine Castagnary, in *Siecle*, June 28, 1879. Cited in George Heard Hamilton, *Manet and His Critics* (New York: Norton, 1969), p. 215.

13. Even in the 1980s, the reactionary sensibilities of a prominent neoconservative journal were offended, even bewildered by this painting's incompatibility with a vapid and standardized set of clichés about Manet's "spontaneity" and "dazzling surfaces": "Confronted by *The Conservatory* of 1879 it is difficult to know what Manet could possibly have had in mind. This is one of those Manets that makes me lose almost total confidence in the artist. It is not so much that the painting is bad—what great painter has not painted terrible paintings?—it is that it is bad in an utterly unadventurous, unexceptional, and banal sort of way. . . . The canvas is painted with a giggling, pedantic hand that turns everything into mud and plastic. The row of spokes on the back of the park bench is almost painful to look at, so laboriously and dully have they been rendered. The figures—the husband leaning over the bench, the wife looking off into the distance—are equally lifeless: fashion plate mannequins painted with no sympathy and not a trace of irony either." Jed Perl, "Art and Urbanity: The Manet Retrospective," *New Criterion*, November 1983, pp. 43–54.

14. Hamilton, *Manet and His Critics*, p. 212. For one of the few conventional art historical treatments of the work, see Bradley Collins, "Manet's 'In the Conservatory' and 'Chez le Pere Lathuille,'" *Art Journal*, 45 (1985), pp. 59–66. See as well the provocative discussion of this work's formal structure in Jeremy Gilbert-Rolfe, "Brice Marden's Painting," *Artforum*, October 1974, pp. 30–38.

15. Michael Fried, *Manet's Modernism, or, the Face of Painting in the 1860s* (Chicago: University of Chicago Press, 1996), p. 314. Fried qualifies this remark, noting the striking unfinished quality of the man's fingertips. I would also note the roughly sketched and markedly scumbled surfaces of the umbrella and the woman's right hip.



Edouard Manet, In the Conservatory, 1879.

attempt to reconsolidate a cohesive visual field, in whose disassembly Manet had already prominently participated. It is an impossible enterprise of fastening together and grounding narrative contents that inherently resisted unification or immobilization, and the reassemblage simulated on an optical level parallels its symbolic evocation (by means of the greenhouse) of a fraudently reconciled “earthly paradise.”

I will examine this painting in relation to social/institutional spaces in which attention would increasingly be claimed as the guarantee of certain perceptual norms and as a synthetic, centripetal force holding together a “real world” against various kinds of sensory or cognitive breakdown. In addition to Manet, this chapter examines the larger problem of realism around 1880 (in the work of Klinger,

Muybridge, and others), where realism is no longer a question of mimesis but of a tenuous relation between perceptual synthesis and dissociation. Thus if Manet achieves a “reality effect” in this image, it is the result of having worked to hold something together, to “contain” things, or to ward off experiences of disintegration. The painting is a complex engagement with the ambiguities of visual attentiveness that Manet knew deeply and instinctively. Equally important, *In the Conservatory* is a figuration of an essential conflict within the perceptual logic of modernity, in which two powerful tendencies are at work. One is a binding together of vision, an obsessive holding together of perception to maintain the viability of a functional real world. The other, barely contained or sealed over, is a dynamic of psychic and economic exchange, of equivalence and substitution, of flux and dispersal that threatens to unmoor the apparently stable positions and terms that Manet seems to have effortlessly arranged.

There are many signs of this binding energy in the painting, but the most striking is the carefully painted face of the woman. As contemporary critics noted, this face was one obvious indication of a shift in Manet’s practice, and in fact part of the specific character of Manet’s modernism turns around the problem of what Deleuze and Guattari call “faciality.”¹⁶ In much of Manet’s work the face, in its casual amorphousness, becomes a surface that no longer discloses interiority or self-reflection, an unsettling site of pictorial effects traceable through the next two decades into the late portraits of Cezanne (including the thematically related *Madame Cezanne in the Conservatory*).¹⁷ Within nineteenth- and twentieth-century modernity “the face is par excellence the substance of expression of the signifier. . . . Capitalist faciality always exists to serve a signifying formula; it is the means whereby the signifier takes control, the way it organizes a certain mode of individuated subjectivation and the collective madness of a machine without any content.”¹⁸ Manet surely sensed early on the volatility of this region, and he understood that to perturb its coherence was at the same time to disrupt and redirect a normative attentiveness. But something quite different is at work in *In the Conservatory*, and it is clearly more than just a tightening up of what conservative critics had called his “messy broken touch,” “his vague and sloppy planes.” Rather it is a

16. See Gilles Deleuze and Felix Guattari, *A Thousand Plateaus*, trans. Brian Massumi (Minneapolis: University of Minnesota Press, 1987), pp. 167–191.

17. Michael Fried discusses a persistent “obduracy or opacity” in Manet’s work that “rebuffs or at least strongly resists all attempts at hermeneutic *penetration*,” in his *Manet’s Modernism*, p. 401; emphasis in original.

18. Felix Guattari, “Les machines concretes,” in *La révolution moléculaire* (Paris: Encres, 1977), p. 376.

return to a more tightly bound order of “faciality,” one that seems to maintain the articulated hierarchy of a socialized body.¹⁹ It is as if for Manet the relative integrity of the face defined (or approximated) a larger mode of conformity to a dominant reality, a conformity that so much of his work evades or dismantles.

Supporting this relatively cohesive faciality, and central to the effect of the entire image, is the woman’s corseted, belted, braceleted, gloved, and beringed figure. Manet’s painting, like this body (and the coiled, indrawn figure of the man), is powerfully marked by a system of compression and restraint.²⁰ These indications of bodies reined in coincide with other kinds of subduing and constraint necessary for the construction of an organized and inhibited corporeality. The flowerpots and vases perform a related enclosure and containment: they are instruments of domestication, which confine, at least partially, the proliferating growth of vegetation surrounding the figures. Even the lathed vertical posts of the bench are little echoes of the cinched figure of the woman, as if the wood, like some malleable substance, is squeezed in the middle with a clamp. (This feature also suggests the mechanical repeatability of the seated figure.) This image then is a holding action, a forcing back of expansive or floating components into a semblance of a fixed pictorial and social organization. The result, however, is a disjunct, compressed, and space-drained field, in which the two figures and the bench all push together, occupying an impossibly crowded area of the conservatory floor. The bench itself seems to be an almost fully two-dimensional shape barely able to accommodate the woman’s hips. The whole space seems to buckle and ripple at certain points, especially in the odd push-pull of the two vases at the lower left, with their disordered figure/ground relation. The thematic of pressure, of squeezing is suggested by Manet’s title for the work, *Dans la serre*—the word *serre*, of course means “greenhouse,” though it originally meant simply “a closed place” and is also a form

19. “The face is produced only when the head ceases to be a part of the body, when it ceases to be coded by the body, when it ceases to have a multidimensional, polyvocal corporeal code—when the body, head included has been decoded and has to be overcoded by something we shall call the Face. . . . To the point that human beings have a destiny, it is rather to escape the face and dismantle the face and facializations, to become imperceptible, to become clandestine.” Deleuze and Guattari, *A Thousand Plateaus*, pp. 170–171.

20. Relative to fashions of the 1860s, the corsets of the mid-1870s were lighter and somewhat less restrictive. Nonetheless, they continued to fulfill their primary function of shaping and constraining. See David Kunzle, *Fashion and Fetishism* (Totowa, N.J.: Rowman and Littlefield, 1982), p. 31: “The lacing and unlacing of the corset were rituals which retained ancient levels of symbolism and the magical associations of the concepts of ‘binding’ and ‘loosing.’ In folk language, to be delivered of a child or to be deflowered, was to be ‘unbound’; to unbind was to release special forms of energy. . . . The state of being tightly corseted is a form of erotic tension and constitutes ipso facto a demand for erotic release, which may be deliberately controlled, prolonged, and postponed.”

of the verb *serrer*, which means to grip, to hold tightly, to clench, to tighten. But as J.-K. Huysmans suggested in his 1879 Salon review, there are *two* inseparable processes at work in this painting. To describe the seated woman, Huysmans uses the unusual phrase “un peu engoncée et revante.”²¹ He thus conjoins the idea of a cramped, bound condition (figured in the confinement of her clothing) with the drifting, unbound process of dreaming, and this is what the painting itself discloses: the reciprocal relation between the demands of an immobilizing attentive synthesis and the psychic flux and perceptual dispersal of dissociation.



Around this moment—the late 1870s and early 1880s—a remarkable overlapping of problems is evident between some practices of visual modernism and the empirical study of perception and cognition, especially the emerging study of pathologies of language and perception in France and Germany. If certain areas of modernism and the empirical sciences around 1880 were both exploring a perceptual field newly decomposed into various abstract units of sensation and related possibilities of synthesis, contemporary research on newly invented nervous disorders, whether hysteria, abulia, psychasthenia, or neurasthenia, all described various weakenings and failures of the integrity of perception and its collapse into dissociated fragments.²² Alongside the discovery of the linguistic disorders grouped under the category *aphasia*, a set of related visual disruptions were described by the resonant term *agnosia*.²³ Agnosia was one of the primary *asymbolias* or impairments of a hypothetical symbolic function. Essentially it described a purely visual awareness of an object, that is, an inability to make any conceptual or symbolic identification of an object, a failure of recognition, a condition in

21. J.-K. Huysmans, “Le Salon de 1879,” in *L'art moderne* (Paris: Union Generale d'Editions, 1975), p. 52.

22. See the related discussion in John H. Smith, “Abulia: Sexuality and Diseases of the Will in the Late Nineteenth Century,” *Genders* 6 (Fall 1989), pp. 102–124.

23. The landmark inaugural work on aphasia is Carl Wernicke, *Der aphasische Symptomencomplex* (Breslau: Cohn und Weigert, 1874); trans. as “The Symptom Complex of Aphasia,” in *Boston Studies in the Philosophy of Science*, vol. 4 (New York: Humanities Press, 1969), pp. 34–97. One of the first full clinical accounts of agnosia is Hermann Lissauer, “Ein Fall von Seelenblindheit nebst einem Beitrage zur Theorie derselben,” *Archiv fur Psychiatrie und Nervenkrankheiten* 21 (1890), pp. 222–270. (Lissauer's text coincidentally contains an account of a patient who could not distinguish between an umbrella and a leafy plant, prominent contents of *In the Conservatory*.) For recent clinical and historical reviews of the problem, see Martha J. Farah, *Visual Agnosia* (Cambridge: MIT Press, 1990); Jason W. Brown, *Aphasia, Apraxia and Agnosia: Clinical and Theoretical Aspects* (Springfield, Ill.: Chas. Thomas, 1972), pp. 201–232; and Jules Davidoff, “Disorders of Visual Perception,” in Andrew Burton, ed., *The Pathology and Psychology of Cognition* (London: Methuen, 1982), pp. 78–97. See also the “clinical tale” of agnosia in Oliver Sacks, *The Man Who Mistook His Wife for a Hat* (New York: Simon and Schuster, 1987), pp. 8–22.

which visual information was experienced with a primal strangeness. In the later clinical work of Kurt Goldstein on the topic in the 1920s, agnosia was a state in which the objects within a perceptual field ceased to be integrated into a practical or pragmatic plasticity, ceased to have intentional or lived coordinates.²⁴ Goldstein's cousin, philosopher Ernst Cassirer, was to characterize agnosia as a disturbance of "the representative function of perception. The perception remains flat, as it were; it is no longer determined and directed toward a dimension of depth, an object."²⁵ But what was thus labeled as pathological behavior could also be seen as a mode of resistance to consuming the world in a productive or socially useful way, a rejection of habitual or conventional patterns that organized perceptual information. Any experiences or aesthetic practices involving a demotivation and desymbolization of perception now had a problematic relation to normative models of behavior.

If the study of aphasia was intertwined with modern reconfigurations of language, the study of agnosia and other visual disruptions produced a range of new paradigms for the explanation of human perception.²⁶ Prior to the nineteenth century the perceiver was generally considered to be a passive receiver of stimuli from exterior objects which formed perceptions that mirrored this exterior world. What took shape in the last two decades of the nineteenth century, however, were notions of perception in which the subject, as a dynamic psychophysical organism, actively constructed the world around it through a layered complex of sensory and cognitive processes, of higher and lower cerebral centers. Beginning in the 1880s and through the 1890s, various models of holistic and integrating neural processes were proposed, especially in the work of John Hughlings Jackson and Charles Sherrington, which challenged localizing and associationist models.

The French psychologist Pierre Janet, in the late 1880s, postulated the existence of what he called the "reality function." He believed that such a function was present in all "normal" mental activity as a capacity for the synthesis of several ideas or perceptions into a larger complex. He repeatedly saw patients with what seemed to be impaired *synthetic* abilities: fragmented systems of sensory response,

24. See Kurt Goldstein, *The Organism* (1934; New York: Zone Books, 1995), pp. 196–198.

25. Ernst Cassirer, *The Philosophy of Symbolic Forms*, vol. 3: *The Phenomenology of Knowledge*, trans. Ralph Mannheim (New Haven: Yale University Press, 1957), p. 239.

26. See the excellent discussion of the cultural and social significance of aphasia in the late nineteenth century in Matt K. Matsuda, *The Memory of the Modern* (Oxford: Oxford University Press, 1996), pp. 79–99.

which he described as a reduced capacity to adapt to reality. One of the key symptoms of this loss of a reality function was a breakdown or weakening of normative attentive behavior, and for Janet attention meant “the power of mental synthesis, the power of a subject to form a new perception, a judgment, to have memories and habits.”²⁷ He consistently described such failure in terms of some greater systemic weakness, leading Freud and Josef Breuer to challenge him in the early 1890s. Dissociation and a malfunction of synthesis, they asserted, were due not to weakness but to “an excess of efficiency” in splitting up mental or perceptual contents.²⁸ For Freud, the problem was not a failure of attention but a redeployment of its functions: attention, he insisted, could not be separated from the dynamic activity of repression. He and Breuer also complained that Janet’s research suffered from being based on data on patients in institutions and hospitals, unlike their more socially estimable (and presumably more somatically healthy) patients.

But Janet’s work, no matter how much it has been disparaged for its “incorrectness” in relation to hysteria, is particularly valuable for its *formal* description of different types of perceptual dissociation—not his often exorbitant classification of various neuroses, but rather his account of common symptoms that traversed so many different kinds of patients: various forms of splitting and fragmentation of cognition and perception, what he called “desagregation,” widely varying capacities for achieving perceptual synthesis, disjunctions between or isolation of different forms of sensory response.²⁹ Again and again he recorded constellations of symptoms involving perceptual and sensory derangements, in which autonomous sensations and perceptions, by virtue of their dissociation and fragmented character, acquired a higher level of intensity. But though I single out Janet, he was simply one of many researchers (obviously including Freud) who discovered how volatile the perceptual field could be, and, perhaps most importantly, demonstrated how dynamic oscillations of perceptual awareness and mild forms of dissociation were part of what was considered normal behavior.³⁰ Thus in no sense am

27. Pierre Janet, *Névroses et idées fixes* (Paris: Felix Alcan, 1898), p. 72.

28. Josef Breuer and Sigmund Freud, *Studies on Hysteria*, trans. James Strachey (New York: Basic Books, 1957), p. 233. See the reevaluation of Janet in relation to Freud, in Ian Hacking, *Rewriting the Soul: Multiple Personality and the Sciences of Memory* (Princeton: Princeton University Press, 1995), pp. 191–197.

29. For Janet’s early work on perceptual disorders and his account of “la désagregation psychologique,” see his *L’automatisme psychologique* (Paris: Felix Alcan, 1889).

30. For some of the background to this research, see Hannah S. Decker, “The Lure of Nonmaterialism in Materialist Europe: Investigations of Dissociative Phenomena 1880–1915,” in Jacques M. Quen, ed., *Split Minds/Split Brains: Historical and Current Perspectives* (New York: New York University Press,

I proposing a “pathologizing” of modernism. Rather I am indicating that out of the empirical study of perception and cognition (including so-called pathological manifestations) emerged powerful *normative* models of subjectivity. A society recognizes itself and its own positivity through the morbid and pathological forms it identifies or invents.³¹

Implicit within such dynamic theories of cognition and perception was the notion that subjectivity is a provisional assembly of mobile and mutable components. More explicit, perhaps, was the idea that effective synthesis of a “real world” was synonymous to a large extent with *adaptation* to a social environment. Thus, within various studies on attention there was a consistent but never fully successful attempt to distinguish two forms of attentiveness: the first was conscious or voluntary attention, which was usually task-oriented and often associated with higher, more evolved behavior. The second was automatic or passive attention, which included for scientific psychology the areas of habitual activity, daydreaming, reverie, and other absorbed or mild somnambulant states. The point at which any of these states could shift into a socially pathological obsessiveness was never clearly defined and could only become evident with some clear failure of social performance. Hippolyte Bernheim, in the early 1880s, directly addressed these issues: “If their attention is self-concentrated, and their minds self-absorbed in an idea or an image, it is sufficient to produce a sort of passive somnambulism, passive only in that it cannot be made to change the condition. And this is so true, that many somnambulists are susceptible to suggestion in the waking condition.”³²

In relation to these problems, a critical question is how one chooses to characterize the state of the seated woman of *In the Conservatory*. Clearly, we might affiliate her with many other figures and faces in Manet’s work. Is she merely another instance of an often-noted Manet “blankness,” psychological emptiness, or disengagement? T. J. Clark offers a rich discussion of the relation of social class to what he calls the “face of fashion” in terms of Georg Simmel’s notion of impersonality

1986), pp. 31–62; and Ernest R. Hilgard, “Dissociation Revisited,” in Mary Henle et al., eds., *Historical Conceptions of Psychology* (New York: Springer, 1973), pp. 205–219.

31. See Michel Foucault, *Madness and Mental Illness* (1954), trans. Alan Sheridan (Berkeley: University of California Press, 1987), pp. 73–75.

32. Hippolyte Bernheim, *Hypnosis and Suggestion in Psychotherapy* (1884), trans. Christian Herter (New York: Aronson, 1973), p. 155. Over a decade earlier, Hippolyte Taine had made a similar claim: “No doubt, though among the somnambulists, persons hypnotized and in states of ecstasy, similar contrasts distinguish the ordinary from the abnormal life, these two lives are not clearly nor entirely distinct; some images of the one always, or nearly always, introduce themselves into the other.” Taine, *On Intelligence*, vol. 1 (1869), trans. T. D. Haye (New York: Henry Holt, 1875), p. 98.



Manet, In the Conservatory, detail.

and the “blase.”³³ Also it is difficult to consider this image without reference to Benjamin’s articulation of modernity as a public sphere in which, for the first time, individuals are systematically habituated *not* to return the gaze of the other. But I believe such readings can be specified and pushed further. Jean-Jacques Courtine and Claudine Haroche insist that in the nineteenth century a new regime of faciality takes shape.³⁴ After nearly three centuries in which the meanings of the human face were explained in terms of rhetoric or language (such as in Charles Le Brun’s 1698 treatise on expression), the face in the nineteenth century comes to occupy a precarious position, belonging to a human being both as a physiological organism and as a privatized, socialized individual subject. Courtine and Haroche see Charles Darwin’s *The Expression of Emotions in Man and Animals*, published in 1872, as the product of a world no longer in communication with that of Le Brun. Darwin’s work is indicative of the split status the face acquires, becoming simultaneously a symptom of an organism’s anatomical and physiological functioning *and*, in its relative impenetrability, the mark of the success or failure of a process of self-mastery and control implicit in the social construction of a normative individual.³⁵ In particular, it is within the new field of mental pathology, with its analyses of hysterics, obsessions, manias, and anxieties, that the face with all its intrinsic motility becomes a sign of a disquieting continuum between the somatic and the social.

With the idea of that continuum in mind, I think it is possible to see the woman, with face and eyes as a special key, as a public presentation, as an impassive mastery of self (perhaps a self-mastery, or recomposing of the self in response to some verbal remark or proposal by the man), which coexists with being in the grip of some thoroughly ordinary involuntary or automatic behavior. We are allowed by Manet, who painted this face with uncharacteristic definition, to ask such specific questions. Is she engaged in thought, or vacuous absorption, or that form

33. See Clark’s chapter on Manet’s *Bar at the Folies-Bergère* (1882) in his *The Painting of Modern Life* (Princeton: Princeton University Press, 1984), pp. 253–254: “Fashion and reserve would keep one’s face from *any* identity, from identity in general. The look which results is a special one: public, outward, ‘blase’ in Simmel’s sense, impassive, not bored, not tired, not disdainful, not quite focussed on anything.”

34. Jean-Jacques Courtine and Claudine Haroche, *Histoire du visage: Exprimer et taire ses émotions, XVIIe–début XIXe siècle* (Paris: Rivages, 1988), pp. 269–285.

35. An ideal of impenetrability was a key part of Baudelaire’s model of dandyism: “The specific beauty of the dandy consists particularly in that cold exterior resulting from the unshakeable determination to remain unmoved.” Baudelaire, “The Painter of Modern Life,” in *Selected Writings on Art and Artists*, trans. P. E. Charvet (Harmondsworth: Penguin, 1972), p. 422.

of arrested (or diverted) attentiveness that borders on a trance?³⁶ Like Freud's Anna O. (who became ill in 1880), is she simultaneously conforming to a learned set of social expectations *and* indulging in the "private theater" of her own day-dreaming?³⁷ It was discovered that in both somnambulant and hypnotic states, sensations, perceptions, and subconscious elements could loosen themselves from a binding synthesis and become floating detached elements, free to make new connections. The particular spatial relation between the two figures in this painting has a curious similarity to one of the early forms of therapeutic practice that came out of the work of Charcot, Janet, and others in the early 1880s at the hospital of Salpêtrière: a method of standing behind so-called hysteric patients and whispering to them while they appeared to be preoccupied and inattentive to their surroundings, so that it seemed possible actually to communicate with a dissociated element of a fragmented subjectivity.³⁸ Dissociation in such cases was linked with an extremely narrowed field of attention.

It's hard to think of another figure of Manet's with this inanimate, waxwork quality. In a sense we are shown a body with eyes open but which do not see—that is, which do not arrest, do not fix, or do not in a practical way appropriate the world around them. They are eyes that denote a momentary state in which a normative perception is suspended.³⁹ Again, it is not so much a question of vision, of a gaze, but of a broader perceptual and corporeal engagement (or in this case, disengagement) with a sensory manifold. If it is possible to pose the suggestion of trance here, it is simply as a forgetfulness in the midst of being wakeful, the in-

36. See Michael Fried's discussion of the uncertain critical response to James Whistler's *Woman in White* in the 1860s, in which the figure depicted was seen as "distracted, in a trance, sleepwalking, mad." For Fried, "what all these characterizations have in common is the idea that the woman's state of mind renders her unaware of being beheld." Fried, *Manet's Modernism*, p. 222.

37. Breuer and Freud, *Studies on Hysteria*, p. 233: "There are no doubt a whole number of activities, from mechanical ones such as knitting or playing scales, to some requiring at least a small degree of mental functioning, all of which are performed by many people with only half their mind on them. This is especially true of people who are of a very lively disposition, to whom monotonous, simple and uninteresting occupation is a torture and who actually begin by deliberately amusing themselves with thinking of something different."

38. Pierre Janet, *The Mental State of Hystericals* (1893), trans. Caroline Corson (New York: Putnam, 1902), pp. 252–253. (This translation should be used with caution.) This text was Janet's medical thesis, written three years after he had been appointed by Charcot as director of the psychology laboratory at the Salpêtrière. William James discusses these clinical practices in *Principles of Psychology* (1890; New York: Dover, 1950), vol. 1, pp. 203–204.

39. According to Pascal Bonitzer, this mix of "fixation and distraction" in Manet and the sense of an "equivocal suspension," are linked to the pervasiveness of photographic modalities. He identifies a melancholy in Manet's work which is inseparable from the serial, mechanical, and disenchanting effects of photography. See Bonitzer, *Decadrages: Peinture et cinéma* (Paris: Cahiers du cinéma, 1987), pp. 73–77.

definite persistence of a transient daydreaming. By the late 1870s, researchers reported that seemingly inconsequential and everyday states of reverie could transform themselves into autohypnosis. The Belgian psychologist Joseph Delboeuf identified reverie as a state in which a potentially dangerous weakening of perceptual norms could take place, at which hallucinatory content could become intermingled with “determinate perceptions.”⁴⁰ William James, himself a painter for a time, in his *Principles of Psychology*, which he began writing in 1878, describes how such states are inseparable from attentive behavior:

This curious state of inhibition can at least for a few moments be produced at will by fixing the eye on vacancy. . . . Monotonous mechanical activities that end by being automatically carried on tend to produce it. . . . The eyes are fixed on vacancy, the sounds of the world melt into confused unity, the attention becomes dispersed so that the whole body is felt, as it were, at once, and the foreground of consciousness is filled, if by anything, by a sort of solemn sense of surrender to the empty passing of time. In the dim background of our mind we know what we ought to be doing: getting up, dressing ourselves, answering the person who has spoken to us. . . . But somehow we cannot start. Every moment we expect the spell to break, for we know no reason why it should continue. But it does continue, pulse after pulse, and we float with it.⁴¹

James gives an account here of what neurologist John Hughlings Jackson had described as “a temporary relaxation of object consciousness, or speaking more simply, we are dim to our surroundings,” a state of “temporary normal dissolution,” synonymous for Jackson with “reverie.”⁴² For him, dissolution meant a

40. Joseph Delboeuf, *Le sommeil et les rêves* (Paris: Felix Alcan, 1885), pp. 87–90. Important sections of this book had been published in the *Revue philosophique* in 1879. See also the discussion of “the common everyday trance” in Peter Brown, *The Hypnotic Brain: Hypnototherapy and Social Communication* (New Haven: Yale University Press, 1991), p. 87. Brown describes a regular rhythm of “ultradian quieting,” that is, a daily pattern of daydream or reverie occurring every 70 to 120 minutes, in which one loses one’s familiar spatiotemporal orientation and the daydream becomes “the workshop of unfinished social and emotional concerns.” The everyday trance produces “a faraway expression. There are fewer facial movements, and there may be an increase in asymmetry between the two sides of the face. Subjects report perceptual alterations with changes in the subjective experience of hearing, seeing, and touch. They tend to engage in fantasy and personal thoughts. Emotional intensity increases despite the relative lack of external expression.”

41. James, *Principles of Psychology*, vol. 1, p. 444.

42. John Hughlings Jackson, *Selected Writings of John Hughlings Jackson*, vol. 2, ed. James Taylor (London: Hodder and Stoughton, 1932), pp. 24–25. The paper cited is “Remarks on Dissolution of the Nervous System Exemplified by Certain Post-epileptic Conditions,” first published in 1881.

disintegration of the highest and most complex operations of the nervous system and the activation of a lower, more automatic functioning. Even though Jacksonian dissolution was a regression to simple and more elementary patterns of behavior, it was nonetheless a breakdown of the arrangements that bound a subjective world together into a unified milieu as a bulwark against dissociation. In this sense *In the Conservatory* is a partial and finally ineffective system of such binding arrangements. If in this image Manet operates hesitantly within the terms of a “reality principle,” it is a “reality” whose legibility is possible only through its reciprocal relation to the creative processes of dissociation. Gaston Bachelard provides a way of approaching Manet’s ambivalence here: “The demands of our reality function require that we adapt to reality, that we constitute ourselves as a reality and that we manufacture works which are realities. But doesn’t reverie, by its very essence, liberate us from the reality function? . . . Reverie bears witness to a normal, useful *irreality function* which keeps the human psyche on the fringe of all the brutality of a hostile and foreign nonself.”⁴³

Manet’s painting discloses a more generalized experience of dissociation even while he maintains a superficially unified surface. Consider how he has painted the man’s eyes (or more accurately, only alluded to them). This is a dramatically different male figure from, say, the young man with the intense wide-eyed omnivorous gaze in *Chez le Pere Lathuille* of the same year (though exhibited at the Salon of 1880), with which *In the Conservatory* has often been associated. In the former, the couple is constituted through the man’s almost excessively attentive gaze and reciprocal gesture of his left arm enveloping the woman. She does not return or exercise in any way a corresponding gaze. *In the Conservatory* presents a very different set of relations. There is a fundamental ambivalence in how the male figure leans over the bench toward the woman and simultaneously holds himself in reserve, how his eyes seem directed at the woman and averted at the same time. In terms of the narrative content of the painting, Manet provides an instance of Simmel’s later formula of modern flirtation, in which “refusal and the withdrawal of the self are fused with the phenomenon of drawing attention to the self” in one indivisible act.⁴⁴

43. Gaston Bachelard, *The Poetics of Reverie: Childhood, Language, and the Cosmos*, trans. Daniel Russell (Boston: Beacon, 1971), p. 13. See also the discussion of the relation between reverie, attention, and fixation in Marcel Raymond, *Romantisme et reverie* (Paris: Jose Corti, 1978), pp. 13–15.

44. Georg Simmel, *On Women, Sexuality and Love*, trans. Guy Oakes (New Haven: Yale University Press, 1984), p. 137.



Edouard Manet, Chez le Pere Lathuille, 1879.

But more significantly, Manet suggests a deeply equivocal attentiveness and distraction: for clearly the punctuality of vision in the man is disrupted far more thoroughly than in the woman. (The possibility of some effect of self-portraiture here should not be discounted, given the similarity of the figure to many surviving images of Manet.)⁴⁵ Inverting the example of *Pere Lathuille*, there is no enactment of visual mastery, no ocular potency here. In a move with intimations of “disfiguration,” Manet shows the two eyes in an asymmetrical, dissociated relation. One eye, his right, is seemingly open, looking beyond and perhaps slightly above the woman beneath him. All we see of the other eye is the lowered eyelid and eyelash. The deliberate disorder and vagueness not only of the direction but even the

45. The resemblance between Manet and the model, Jules Guillemet, had been noted numerous times by Manet’s contemporaries. See, for example, the entry on this painting in *Manet 1832–1883* (New York: Metropolitan Museum of Art/Harry N. Abrams, 1983), pp. 434–437.

efficacy of his glance is one of the striking features of the painting.⁴⁶ Perhaps he is looking at the woman's umbrella, her gloved hand and the loose glove it holds, the pleats of her dress, perhaps even at the ring on her finger. But whatever this effectively cross-eyed figure sees (if anything at all), it is as a disunified field, with *two disparate optical axes*.⁴⁷ Perhaps the eyes indicate the moment when attentiveness shifts into that "eclipse mentale" that Janet described, or that vacancy in which, as Breuer insisted, awareness of an immediate environment grows dim. Equally plausibly, it may be a gaze profoundly disturbed, even disabled by the multiple sites of libidinal or fetishistic fixation, by their unstable and shifting valences. The attentive subject here is part of what Paul Ricoeur calls "the open state of the universe of signs" in which "we are ceaselessly at the juncture of the erotic and the semantic. The power of the symbol is due to the fact that double meaning is the mode in which the very ruse of desire is expressed."⁴⁸ In this way, "symbols" like the glove, the umbrella, the spiky plant, in all their overloaded semiotic banality, stand for the irreducibly diffuse attentiveness that is continually deflected and misaligned by the gazes within this compressed reversible world of the green house.⁴⁹

If the railing in *The Balcony* charted some of the visual ambiguities and instabilities within that painting, the parallel vertical posts of the bench might offer a related diagram for *In the Conservatory*. They are figurations of the unfocused and disunified nature of perception implied across the work: as parallel lines they define a principle of *nonconvergence*, in which the binocularity of vision is not united or synthesized on a specific plane or point.⁵⁰ It would be the diagram of a

46. The notion of efficacy as a component of "normal" vision is, of course, highly problematic. See the discussion of how a "man with the weakest eyes" can be shown "to have the strongest vision," if the attentive vision is "properly strategic," in David J. Levin, *Richard Wagner, Fritz Lang and the Nibelungen: The Dramaturgy of Disavowal* (Princeton: Princeton University Press, 1998), pp. 101–109.

47. By the late 1860s Ernst Mach was lecturing on the paradoxes of binocular disparity, insisting that "every observer is composed really of two observers," and describing the binocular field as constituted out of a fundamental experience of visual displacement, in his "Why Has Man Two Eyes" (1867), in *Popular Scientific Lectures*, trans. Thomas J. McCormack (La Salle, Ill.: Open Court, 1893), pp. 66–88.

48. Paul Ricoeur, *The Conflict of Interpretations*, ed. Don Ihde (Evanston: Northwestern University Press, 1974), p. 66.

49. On the organization of the gaze in Manet's multigure paintings, see Fried, *Manet's Modernism*, pp. 288–291. See also the discussion of Manet in Pierre Bourdieu, *The Rules of Art: Genesis and Structure of the Literary Field*, trans. Susan Emanuel (Stanford: Stanford University Press, 1996), pp. 131–137: "Manet wrecks the social foundation of the fixed and absolute point of view of artistic absolutism (just as he wrecks the idea of a privileged place for light, from now on appearing everywhere on the surface of things): he establishes the plurality of points of view, which is inscribed in the very existence of a field."

50. By the mid-nineteenth century the ophthalmological condition of strabismus had been well studied, and it complicated explanations of binocular vision. Helmholtz describes one common form of the problem in which "the axes of the two eyes cannot be made parallel, that is, the eyes are either conver-

vision that had lost or abdicated a voluntary capacity to effect an optical convergence, a convergence without which a normative attention would be impossible. Instead, the idea of parallel optical axes, in spite of the apparent rigidity, suggests a splitting apart, a drift of binocularity beyond any imperative to produce a cohesive world of focused clarity. The idea of unreconciled binocular disparity necessarily situates difference and nonidentity within the midst of perception.

But it is more than a question of how the man's eyes have been literally represented. The disruption of a seamless binocular synthesis is evident as well from our viewpoint as spectators. For example, the right side of the bench seat appears as if seen from a standing position, looking down. However, the left side, of which we see a small surface just below the woman's right hip, seems to be seen more head on, as if by someone seated across from her. The horizontal line formed by the top of the vertical face of the bench seat along the lower edge of the canvas is disturbingly discontinuous with the related line at the left side, as if the single object is seen by two nonreconciled eyes. There is also an odd sense of displacement caused by the proximity of the cylinders of the man's thighs and the parallel cylinders of the two pots of a similar color to the lower right. It is as if a trick of refraction, a failure of optical resolution has split or cut the man's lower legs out from under him. At the same time, the uncertain positions of the two pots at the lower left signal a failure of a binocular construction of coherent relations of distance and depth.

So within a work depicting two apparently attentive figures, we also encounter two different states of distraction, around which the stability and unity of the painting begin to erode. That surpassing or breakdown of normative attentiveness, whether as autohypnosis or some other mild trancelike state, provided conditions for new mobile and transient syntheses, and we see in this painting a whole set of associative chains that are part of a libidinal economy, exceeding the binding logic of the work. Freud, in particular, linked an involuntary mobile attention with the state just before falling asleep and with hypnosis.⁵¹ One can note here the

gent or divergent, the angle between the visual axes being practically constant, no matter what direction the eyes are gazing." Hermann von Helmholtz, *Treatise on Physiological Optics*, vol. 3, ed. James P. C. Southall (New York: Dover, 1962), p. 405. Strabismus also (incorrectly) become associated with a range of nervous and hysterical disorders, as well as hypnotic and somnambulant states, in which the failure of binocular vision was linked with psychological processes of dissolution and dissociation. See, for example, Henri Parinaud, "Paralysis of the Movement of Convergence of the Eyes," *Brain* 25 (October 1886), pp. 330–341; J.-M. Charcot, *Clinical Lectures on Diseases of the Nervous System*, ed. Ruth Harris (London: Tavistock, 1991), pp. 280–281; and the later overview of the problem in Janet, *Neuroses et idées fixes*, pp. 73–74, 186–189.

51. Sigmund Freud, *The Interpretation of Dreams*, trans. James Strachey (New York: Avon, 1965), p. 134.

metaphoric displacements and slippage between the cigar, fingers, the rings on the fingers, the closed umbrella, bracketed wrist, and the rebus-like chain of the pink flowers that become ear, eyes, lips, and then flowers again. Also the man's fingertip is curiously attenuated to a point like the huge spiky green leaves behind him, and there is a play of resemblance between the leaves of the engulfing plant to the right of the man and the pleats of the woman's skirt. What the folds of the pleats and the unopened umbrella define as enclosure and inaccessibility, the plant, almost too overwhelmingly in its eroticism, offers as open, accessible, but outside of both their fields of vision. To redeploy the words of Julia Kristeva: "Here we find the principles of metonymy and metaphor indissociable from the drive economy underlying them. . . . We must also add to these processes the relations (eventually representable as topological spaces) that connect the zones of the fragmented body to each other and also to 'external' 'objects' and 'subjects.'"⁵² These are a few of the ways that attention as a selective or, some might say, repressive function drifts away from itself, cracking and scattering the cohesion of the work. At the same time it is important to be aware of the larger trajectory in which the seamless modulation of a normative attention into a dispersed distraction is, in fact, the very condition for its reassemblage and rebinding into the repetitive laws of the unconscious.

Another obvious sign of the binding energy of the work is the presence of two (wedding?) rings, adjacent to each other near the very center of the painting. Manet's ambivalence about this important area of the painting is revealed, in part, by the anatomically anomalous form of the woman's left hand. It appears to have a thumb and only three fingers, thus putting in question the exact location (and significance) of her bands. Since it was first exhibited there has been conflicting speculation on whether Manet intended to show a married couple (and in fact his models for this work were married, M. and Mme. Guillemet) or an image of an illicit rendezvous between a man and a woman married to other partners. I would insist that this indeterminacy is a crucial part of the work. It discloses the split relation of Manet to his subject—it is an image of conjugality and adultery simultaneously.⁵³ The wedding bands and the alliance thus implied make up a field of

52. Julia Kristeva, *Revolution in Poetic Language*, trans. Margaret Waller (New York: Columbia University Press, 1984), p. 28.

53. One of the popular paintings at the Salon of 1879 was Henri Gervex's *Retour de Bal*, which much more explicitly represented a fractured conjugality. In it, the anguished private estrangement of an affluent couple is shown in implied contrast to the public performance of happy union that would have been required at the event from which they have just returned.



Manet, *In the Conservatory*, *detail*.

fixed positions, of limits, of desire contained and channeled, a system in which the couple is a binding stasis.⁵⁴ One of the original meanings of the German word *Bindung* was the hooping of a cask of liquid, that is, a containing of flux, like the hooped, corseted torso of the woman which is part of this obsessive holding in.⁵⁵ But curiously, and perhaps only of marginal significance, the French translation of Freud's *Bindung* is *liaison*.⁵⁶ If the "liaison" is what holds things together psychically, the figuration of an adulterous liaison in this painting is also what undermines that very binding.⁵⁷ Adultery, in the context of modernization, no longer has

54. Amplifying my earlier remarks about the connotations of the verb *serrer* and the thematic of binding and enclosure, the very name of Manet's models suggests another kind of enclosing. In French, *guillemet* means "quotation mark" or "inverted comma." Thus the couple themselves, the Guillemets, become a literal bracketing and putting in question of their own presence in the work, an ironic and graphic containing of the central ambiguity of the hands and rings.

55. Using Duchampian terminology, one could read the male and female, kept apart by the grid of the bench and differentiated by their two noncommunicating fields of vision, as a "blossoming" bride and bachelor enmeshed in a verdant anticonjugal machine of perpetual nonfulfillment.

56. See Jean Laplanche and J.-B. Pontalis, *The Language of Psycho-analysis*, trans. Donald Nicholson-Smith (New York: Norton, 1973), pp. 50–52.

57. In the same way, the hands that symbolically anchor the painting also have, in terms of the painter's technical practice, the capacity to bind or unbind the representational contents of the painted surface. As many commentators on his work have concluded in one way or another, the question of the hand is pivotal for Manet. See, for example, the striking deformation of the left hand of the male figure in *Chez le Pere Latbuille*, suggesting a divergence between the capabilities of the hand and the controlling, encompassing potential of the arm.

a transgressive status, but is what Tony Tanner calls “a cynicism of forms,” merely another effect of a dominant system of exchange, circulation, and equivalence, which is what Manet can only indirectly control.⁵⁸ The perceptual dispersal characterizing the man corresponds to a larger subjective confusion and differentiation which Simmel described not only as elements of “male” objective culture but as the very preconditions for infidelity: “the capacity to decompose oneself into a plurality of distinctly different essential tendencies, to detach the periphery from the center, and to make interests and activities independent of their integral interconnection.”⁵⁹ But Manet takes these features beyond the limits of a normative social functioning and beyond the fulfillment of a rote infidelity.

Manet here is attempting, as in many of his important paintings, to negotiate the ambivalent status of the feminine. The cultural corrosion of conjugality is only one part of a larger disintegration of premodern positions of the male and female. Christine Buci-Glucksmann has described how “the violent insertion of women into the process of commodity production destroys traditional differences, whether material (differential location) or symbolic. As labor and society assume a mass character, women themselves become ‘mass articles’ and lose both their ‘natural’ qualities (female essence defined by the reproduction of life) and their poetic aura. . . . This societal dynamic therefore made it essential to redefine the symbolic features distinguishing the feminine from the masculine.”⁶⁰ On one hand it’s possible to consider the work as an effort by Manet to secure man and woman into stable and legible positions and to “naturalize” modern femininity metonymically through the overlapping of fashion, the body, and plant life. But on the other, Manet is situating this work within a world in which those differences and positions are disrupted by a logic of exchangeability. The uncertain form of the greenhouse itself, in its disorganization of the cultural and the natural, its collapsing of interior and exterior, of public and private, parallels other effects of derangement and destabilization in the painting.⁶¹

58. Tony Tanner, *Adultery in the Novel: Contract and Transgression* (Baltimore: Johns Hopkins University Press, 1979), p. 18.

59. Simmel, *On Women, Sexuality and Love*, p. 71.

60. Christine Buci-Glucksmann, *Baroque Reason: The Aesthetics of Modernity* (1984), trans. Patrick Camiller (London: Sage, 1994), p. 97.

61. “The spread of greenhouses in the nineteenth century deserves attention from historians of private life. There were manifold varieties: winter gardens, hothouses sheltering exotic plants throughout the year, temperate greenhouses, heirs of the orangerie, where vegetation passed the winter protected from the cold. Long reserved for the aristocracy and the very wealthy, greenhouses proliferated, particularly in England but also in central Europe and then in France. . . . It extended the dwelling and bore witness to the expansion of the private sphere. Greenhouses provided a place to stroll in all weathers,



Edouard Manet, Before the Mirror, 1876.

Just a few years earlier, one can see Manet working within a different set of optical possibilities, alien to the system of constraints defining *In the Conservatory*. His *Before the Mirror* (1876) discloses a highly “unbound” visual field in which attention has shifted away from any requirement to hold its objects together. The figure, whether in the act of dressing or undressing, is in a condition of unconfinement, with the loosened state of the corset inseparable from a corresponding unfastening of visual attentiveness from any binding fixation.⁶² Both the gaze of the woman toward herself in the mirror and the nominally voyeuristic gaze of the spectator at this scene are dispersed and scattered beyond any punctual or coordinate setup. Along with the dissolution of all the classical operations of the mirror

which caused flowery arbors to be woven and benches placed in them. Greenhouses became places for fortuitous meetings, rendezvous, adventures. They thwarted the surveillance that prevailed in the domestic space.” Alain Corbin, *The Foul and the Fragrant: Odor and the French Social Imagination*, trans. Roy Porter et al. (Cambridge: Harvard University Press, 1986), p. 189.

62. For a recent art historical discussion of this painting, see Carol Armstrong, “Facturing Femininity: Manet’s ‘Before the Mirror,’” *October* 74 (Fall 1995), pp. 75–104.

(an optics of identity, reflection, and mimetic correspondence), even the possibility of a normative attention organized as a social effect is abolished here, as is the binary, conjugal organization explicit in *In the Conservatory*.⁶³ Using Kristeva's analysis of late nineteenth-century French poetry, we can in a general way position *Before the Mirror* as a signifying system that pushes away from the symbolic order of verisimilitude, spatiality, temporality, and figuration. It is a system that points instead toward instinctual, mobile, amorphous events, that disrupts signification and opens onto "a jouissance that divests the object and turns back toward the autoerotic body."⁶⁴ In *Before the Mirror* a plural sensory attentiveness comes into play, loosening the subject's hold on a world of objects, and it flows outside of line, boundary, and fixed positions of all kinds. Intensities of rhythm and nonreferential color are activated perhaps more exuberantly than in any other painting by Manet.

Returning to *In the Conservatory* is like witnessing an ossification of the flux and vibration at the heart of *Before the Mirror*.⁶⁵ Part of the inanimate oppressiveness of the work derives from the two hands at its center, hands that almost make contact but do not: this is a pivotal nonevent. The inertia weighing down the image is a consequence of a fundamental withdrawal of the possibilities of *gesture*, which according to Giorgio Agamben is part of a particularly modern failure of ethos, of character.⁶⁶ These hands describe a condition not simply of con-

63. If *Before the Mirror* is outside of that territorialized dualist setup, it is partly because of what, in Deleuze and Guattari's terms, would be a "becoming-woman" that is operative in much of Manet's work, and clearly this problem overlaps with the larger question of Manet's "femininity." "There is no becoming-man because man is the molar entity par excellence, whereas becomings are molecular. . . . Man constitutes the majority, or rather the standard on which the majority is based: white, male, adult, 'rational,' etc., in short, the average European, the subject of enunciation. Following the law of arborescence, it is this central Point that moves across all of space or the entire screen, and at every turn nourishes a certain distinctive opposition." Deleuze and Guattari, *A Thousand Plateaus*, p. 292. For Deleuze and Guattari, "becoming-woman" is one of the provisional routes out of binding organizations and segmented structures of representation, interpretation, and production. See also the important critique of this concept in Elizabeth Grosz, *Volatile Bodies: Toward a Corporeal Feminism* (Indianapolis: Indiana University Press, 1994), pp. 173–183.

64. Kristeva, *Revolution in Poetic Language*, p. 49.

65. Eugene W. Holland discusses Baudelaire's writing in terms of an instability and oscillation related to what I am outlining here in Manet's work, in *Baudelaire and Schizoanalysis: The Sociopoetics of Modernism* (Cambridge: Cambridge University Press, 1993): "The perpetual self-invention of 'free subjectivity' defining modernity is played out in the form of alternating cycles of decoding and recoding, of daring innovation followed by hyperanxious self-consolidation, followed by renewed innovation, and so on" (p. 274).

66. "An era that has lost its gestures is, for that very reason, obsessed with them; for people who are bereft of all that is natural to them, every gesture becomes a fate. And the more the ease of these gestures was lost under the influence of invisible powers, the more life became indecipherable. It is at this stage that the bourgeoisie—which, only a few decades earlier, had still been firmly in possession

straint but of a larger *incapacitation*, a state of numbed suspension. They are hands which, in their vague slackness, describe a renunciation of *potentia* (what Spinoza outlined as a capacity for being affected), of any expansion of practical being. They suggest a tactility that has become anesthetized or even paralyzed, and the proximity of the man's cigar to the woman's hand conveys, with its insinuation of casual sadism, the possible intensity of sensation necessary to produce a tactile response. The hands are part of a larger drift and gap between different perceptual systems, a lessening of the mutual awareness of the different senses—say, between sight and smell.⁶⁷ Given that the man's eyes are barely discernible and that his mouth is invisible amid the strange concavity of his beard, his prominent nose suggests that the sense of smell may be significant here. It would be hard to rule out the visual hint of an olfactory attentiveness, of the kind Freud described in a letter to Fliess in which he stressed that the smell of flowers is the disintegrated product of their sexual metabolism.⁶⁸

The indication of disjunct or damaged layers of sensory response is apparent most acutely at the center of the painting: we have the split between the woman's one gloved, or anesthetized, hand and the other bare, vulnerable, ready to receive or initiate a caress. Both of the hands here, it should be said, are simultaneously disembodied and yet excessively carnal. They emerge out of the cuff or sleeves like embarrassing, awkward body parts, appendages that avoid contact but aggressively assert their status as flesh. No reproduction can convey the raw, scumbled, and willfully displeasing way in which Manet has patched together the mottled surfaces of these two hands, in marked contrast to the smooth and polished face of the woman. The hands become an indirect disclosure of all the psychic dispersion and unease that Manet has attempted to repress and seal within these ostensibly self-contained figures. Because the woman has something of the enameled impassivity of a Bronzino portrait, it might seem reasonable to read the astonishing contortion of her hand, its languid cursiveness, as a neo-mannerist re-fashioning of the body. But any attempt here to confine the body within the sphere of the merely decorative overlaps disturbingly with another layer of signs: the bend

of its symbols—falls a victim to interiority and entrusts itself to psychology." Giorgio Agamben, *Infancy and History: Essays on the Destruction of Experience*, trans. Liz Heron (London: Verso, 1993), p. 137.

67. Within discussions of attention, there was considerable debate over whether one could attend to more than one sense simultaneously. See, for example, the negative argument in Ernst Mach, *Contributions to the Analysis of Sensations* (1885), trans. C. M. Williams (Chicago: Open Court, 1897), p. 112.

68. Sigmund Freud, *The Origins of Psycho-analysis: Letters to Wilhelm Fliess, Drafts and Notes 1887-1902*, trans. Eric Mosbacher and James Strachey (New York: Basic Books, 1954), pp. 144-145.



Caravaggio, *The Fortune Teller*, c. 1594.

of the woman's wrist, at a right angle to her forearm, is as anatomically extreme as many contemporary images of hysterical contracture.⁶⁹ Her fingers are improbably flexed in a state of simultaneous tension and flaccidity. The inefficacy of gesture here as a form of interchange and self-expression occurs at the historical moment when the marks of pathological impairment and deficit coincide with the congealing of the body into an armored aestheticized exterior. To position Manet's painting more concretely, compare it with a related image that would have been familiar to him, Caravaggio's *The Fortune Teller* in the Louvre. I say "related" to indicate a painting in which most of the important terms of *In the Conservatory* (the activation of eyes, hands, bodies, gloves, ring) are present but reversed: in the Caravaggio there is intense optical contact, tactile contact, a reciprocal system of investment in the *transactional* nature of the encounter, infused with the interplay of social, libidinal, and economic difference. Perhaps the most striking parallel is

69. See, for example, the hands and wrists in illustrations of patients at the Salpêtrière in J.-M. Charcot and Paul Richer, *Les démoniaques dans l'art* (Paris: Delhay et Lecrosnier, 1887), pp. 103–105.

the expectant young cavalier with one hand bare, one gloved holding the other glove. In *The Fortune Teller*, however, this ardent youth proffers his bare palm to his female interlocutor, for whom the hand becomes the field on which a destiny of both desire and loss is fatefully inscribed.⁷⁰ The inverted effect of Manet's work lies in its figuration of two subjects for whom the very possibility of destiny is no longer historically meaningful.

If it is possible to see activity or even the simulation of gesture in *In the Conservatory*, we can begin with the man's left hand. It seems shaped, albeit hesitantly, into a pointing finger, as if the possibility of such a signifying gesture has atrophied from the thousands of times it has been deployed through several centuries of Western painting. But if the hand can be separated from the weight of that history, perhaps we can understand it as a constitutive element of the painting's larger dispersion of perception. The pointing finger, indicating a focus of attention that diverges from his already ambivalent glance (and in a direction opposite from where the umbrella directs our eye), is one more confirmation of the impossibility of a direct perception, of an attention that was an immediate possession of its object, of a lost theological schema within which the pointing finger had once functioned to denote a plane of transcendence. The man's hand (and to a lesser extent the woman's umbrella) are key parts of a system of deflection, in which vision is bound up in a relational field within which every point of fixation is a deferral and relay to another one.⁷¹

A decade earlier Charles S. Peirce had begun to articulate a systematic account of the impossibility of direct intuition and of the *interpretive* processes through which alone reality can be understood. One of the key elements of

70. The remoteness of the particular historical world of the Caravaggio painting from that of Manet is suggested by Walter Friedlaender: "In his early genre painting of *The Fortune Teller*, Caravaggio repeats Lotto's 'jeu de main,' using it to express the subdued relationship between the boyish cavalier and the shrewd young gypsy. The importance of the hands as an expression of individual consciousness rather than merely as instruments of active gesture had been utterly neglected in the period of the maniera, when an absorption in eurythmy, symbolism or empty decoration gave no opportunity for such psychological interpretations." Friedlaender, *Caravaggio Studies* (Princeton: Princeton University Press, 1955), p. 147.

71. Another painting in the Louvre worth considering alongside *In the Conservatory* is Poussin's *The Arcadian Shepherds*, in which hands with pointing fingers are crucial to the operation of the work. Louis Marin's analysis of this work makes clear how its figuration of utopia is inseparable from the simultaneous mapping out of death, absence, and the finitude of historical subjectivity. See Louis Marin, *To Destroy Painting*, trans. Mette Hjort (Chicago: University of Chicago Press, 1995), pp. 65–94. In the pseudo-Arcadia of Manet's *Conservatory*, however, the pointing finger has no effective links with the discursive universe of Poussin, and the greenhouse itself, with its frozen temporality, becomes a kind of tomb from which memory and history have been excluded, and the dehistoricized subjectivity thus produced coincides with a congealed present that can only be described as deathlike.



Nicolas Poussin, The Arcadian Shepherds, 1636.

Peirce's anti-Cartesianism was his insistence that cognition and perception could only occur indirectly, through thoughts which are signs. At the center of Manet's image, the man's left hand recalls the example Peirce repeatedly used to describe an indexical sign. "We now find that, besides general terms, two other kinds of signs are perfectly indispensable in all reasoning. One of these kinds is the *index*, which like a pointing finger exercises a real physiological force over the attention, like the power of a mesmerizer, and directs it to a particular object of sense."⁷² In the context of Manet's *In the Conservatory*, with its own suggestion of absorbed or trancelike states, Peirce's association of the index with hypnotism is of particular interest. Peirce insisted that indexical signs act on the nervous system, "they direct the attention to their objects by blind compulsion. . . . A rap on the door is an index. Anything which focusses the attention is an index. Anything which startles

72. Charles S. Peirce, *Collected Papers of Charles Sanders Peirce*, vol. 8, ed. Arthur W. Burks (Cambridge: Harvard University Press, 1958), p. 42. The citation is from an 1885 review of Josiah Royce, *The Religious Aspect of Philosophy*.

us is an index, in so far as it marks the junction between two portions of experience.⁷³ Peirce's use here of the phrase "blind compulsion" is a vivid intimation of the nonoptical operation of an attentive consciousness; that is, it can make something conceptually present which is perceptually absent. Could the male figure be pointing at the woman's strangely disembodied left hand, or is he noting the removal of the glove (Alfred Binet, Richard von Krafft-Ebing, and others in the 1880s noted the prevalence, especially in male subjects, of a hand fetishism and glove fetishism)?⁷⁴ In any case, the frozen character of the scene, or what we could call its powerful system of fixations and inhibition, coexists with another logic of *errance*, with the wandering of a sensory body that seeks pathways out of binding arrangements of all kinds.



One of the folds in the painting, where attentiveness produces its own dissolution, takes on concrete form in the pleats of the woman's dress, almost like the legless end of a mermaid beached on the greenhouse bench, and it opens onto a whole new economic organization of distraction with which much of Manet's late work is intertwined. He shows us here a rather detailed image of what is clearly a fashion of late 1878, a walking-out dress in the "Princess" style which had dramatically slimmed down women's silhouettes, forcing the bustle into at least temporary obsolescence. One can note its double skirt (the pleats are part of the underskirt), its close-fitting hip-length jacket or "cuirass" bodice with center-front buttons and yoke of black braid, and its tight sleeves with lace cuffs slightly flaring at the wrists. This is not high fashion, but rather the day dress of a stylish, cultivated member of the middle class, and perhaps unusual in this year for its relative austerity. Interesting here is the unusual inclusion of a belt as part of this kind of ensemble: Manet presents a figure more tightly bound than even contemporary conventions required. Especially within the emerging commodity world of fashion, the ephemerality of attentiveness comes into play as a productive component of modernization, and the display here, the body an armature for the commodity, is a momentary congealing of vision, a temporary immobilization within

73. Charles S. Peirce, *Philosophical Writings of Peirce*, ed. Justus Buchler (New York: Dover, 1955), pp. 108–109.

74. Richard von Krafft-Ebing, *Psychopathia Sexualis* (1886), trans. Harry E. Wedeck (New York: Putnam, 1965), pp. 38–39; Alfred Binet, "Le fétichisme dans l'amour," *Revue philosophique* 25 (1888), pp. 142–167, 252–275. See the important assessment of both these authors in Emily Apter, *Feminizing the Fetish: Psychoanalysis and Narrative Obsession in Turn-of-the-Century France* (Ithaca: Cornell University Press, 1991), pp. 15–38.



ROBE EN CACHEMIRE (DEVANT).

ROBE EN MOUSSELINE DE LAINE.

Modèles de chez M^{me} Fladry, rue Richer, 43.*Image from La Mode illustrée, November 1878.*

a permanently installed economy of attraction/distraction. Fashion works to bind attention onto its own pseudo-unity, but at the same time the intrinsic transience of this form undermines Manet's attempt to integrate it into the semblance of a cohesive pictorial space, and contributes to the derangement of visual attention traced out across its surface.

Manet in 1879 precedes a major turning point in the visual status of the fashion commodity: two years later in 1881 Frederic Ives patented his half-tone printing process, which would allow photographs to be reproduced on the same page as typography. This was to set up on a mass scale a new virtual field of the commodity-as-image, and along with it new rhythms of attentiveness that would increasingly become a form of work, work as visual consumption. In this painting Manet elegantly discloses what Walter Benjamin was to articulate so bluntly in his Arcades project: not only is it an image of what Benjamin called "the enthronement of merchandise," but the painting illustrates Benjamin's observation that the essence of fashion "resides in its conflict with the organic. It couples the living body to the inorganic world. Against the living, fashion asserts the rights of the corpse and the sex appeal of the inorganic."⁷⁵ Thus despite Manet's play here with the image of adorned woman as a flower among flowers, or of fashion as a blossoming forth into a luminous apparition of the new, the commodity is part of the larger suffocating organization of the painting.⁷⁶ The inertness of the woman on display here, with a gaze that no longer reflects a world or projects an interior, becomes an appropriate object for the petrifying gaze of a new consumer-observer.⁷⁷ But as Georg Simmel observed, fashion within late nineteenth-century modernity was also one of the forms with which human beings "seek to save their inner freedom

75. Walter Benjamin, *Reflections*, trans. Edmund Jephcott (New York: Harcourt Brace, 1978), pp. 152–153. Terry Eagleton extrapolates from Benjamin's remarks: "In the presence of fashion, that supreme cult of the commodity, we are in the presence of death—of a hectic repetition that gets precisely nowhere, a flashing of mirror upon mirror that believes by thus arresting history it can avoid death, but in this orgy of matter succeeds only in being drawn more inexorably into its grasp." Eagleton, *Walter Benjamin: or Towards a Revolutionary Criticism* (London: Verso, 1981), p. 35.

76. Manet's successful entry at the 1882 Salon, *Spring*, represents the actress Jeanne de Marsy dressed in clothes selected by the artist. In what was to have been a series of four "seasonal" paintings, we see here the shift from a cycle of natural rhythms to the repetitive introduction of "new" styles and products. On the economic and promotional rhythms of the emerging fashion industry, see Gilles Lipovetsky, *The Empire of Fashion: Dressing Modern Democracy*, trans. Catherine Porter (Princeton: Princeton University Press, 1994), pp. 56–59.

77. See Theodor W. Adorno, *Aesthetic Theory*, trans. Robert Hullot-Kentor (Minneapolis: University of Minnesota Press, 1997), p. 316: "By suspending aesthetic values such as those of inwardness, timelessness, and profundity, fashion makes it possible to recognize the degree to which the relation of art to these qualities, which are by no means above suspicion, has become a pretext. Fashion is art's permanent confession that it is not what it claims to be."



Edouard Manet, Spring, 1881.

all the more completely by sacrificing externals to enslavement by the general public.⁷⁸ In this sense fashion would be a protective shield of signifiers, a reflective armor carefully assembled to mask a core of social and psychic vulnerabilities. That double-sidedness of fashion in the painting corresponds to a split between a socially normative attentiveness to a public exteriority and a subjective withdrawal,

78. Georg Simmel, *On Individuality and Social Forms*, ed. Donald N. Levine (Chicago: University of Chicago Press, 1971), p. 313. The clothing of the male figure in this painting is equally important. Mark Wigley suggests some of the problems implicit in the question of men's fashion: "Inasmuch as men's clothing is standardized, it is able to act as a mask behind which the individual is shielded from the increasingly threatening and uncontrollable forces of modern life (forces that were themselves understood as feminine). . . . The mask is a means of mental survival. The man cannot afford to wear his sensuality or any other part of his private life on the surface like a fashionable woman does. Masculinity is no more than the ability to keep a secret; and all secrets are, in the end, sexual. The disciplinary logic of standardization is, of course, psychological." Wigley, "White Out: Fashioning the Modern," in Deborah Fausch et al., eds., *Architecture: In Fashion* (Princeton: Princeton Architectural Press, 1994), p. 210.

and to how inattentiveness and reverie can become a makeshift strategy of freedom and resistance.⁷⁹

In 1874 the poet Stéphane Mallarmé wrote and produced, on his own, several issues of a fashion magazine called *La Dernière Mode*.⁸⁰ This project was fully continuous with the emerging world of consumer culture, in that it was not immediately distinguishable from the dozen or more fashion periodicals already circulating in France alone at this time. At the same time, Mallarmé's magazine was perhaps the earliest self-reflexive exploration of this new arena of objects and events, disclosing the inseparability of the stultifying and emancipatory effects of the fashion commodity.⁸¹ While discussions of women's clothing and jewelry are prominent, each issue of the publication outlines a field of objects that includes the theater, opera, dance, music, exhibitions and spectacles of all kinds, food, etiquette, interior decoration, and vacation travel. The pages of *La Dernière Mode* become a kaleidoscopic decomposition and displacement of the very objects and social experiences that are evoked so glitteringly. For all its charm, Mallarmé's world coincides with the ceaseless pattern in which new products, spectacles, and experiences appear only to be supplanted by others: and within this world, to hold for too long onto any object would be a ruinous immobility. Attention in Mallarmé, as Leo Bersani has noted, always moves away from its objects, undermining any possibility of a fully realized presence.⁸² The text of *La Dernière Mode* is a mobile

79. "In the age of the growing powerlessness of subjective spirit vis-à-vis social objectivity, fashion registers the alien excess of objectivity in subjective spirit, which is painful yet all the same a corrective of the illusion that subjective spirit exist purely within itself. Against its detractors, fashion's most powerful response is that it participates in the individual impulse, which is saturated with history." Adorno, *Aesthetic Theory*, p. 316.

80. For a complete facsimile edition, see Stéphane Mallarmé, *La Dernière Mode: Gazette du Monde et de la Famille* (Paris: Ramsay, 1978).

81. For a thorough study of Mallarmé's magazine project and the larger context of contemporary French fashion publications, see Jean-Pierre Lecercle, *Mallarmé et la mode* (Paris: Librairie Segquier, 1989). Another valuable work, especially for its analysis of Mallarmé's three primary editorial pseudonyms, is Roger Dragonetti, *Un fantôme dans le kiosque: Mallarmé et l'esthétique du quotidien* (Paris: Seuil, 1992), esp. pp. 87–150. See also Sima Godfrey, "1874: Haute Couture and Haute Culture," in Denis Hollier, ed., *A New History of French Literature* (Berkeley: University of California Press, 1989), pp. 761–768; Michel Lemaire, *Le dandyisme de Baudelaire à Mallarmé* (Paris: Klincksieck, 1978), pp. 261–269; and Rhonda Garelick, *Rising Star: Dandyism, Gender, and Performance in the Fin de Siecle* (Princeton: Princeton University Press, 1998), pp. 47–77. Of enduring value are the pages on fashion in Jean-Pierre Richard, *L'univers imaginaire de Mallarmé* (Paris: Seuil, 1961), pp. 297–304.

82. Leo Bersani, *The Death of Stéphane Mallarmé* (Cambridge: Cambridge University Press, 1982), pp. 74–75. Elsewhere, Bersani sees Mallarmé offering his contemporaries "a lesson in the nonpresentness constitutive of human attention and expression." Bersani, *The Freudian Body: Psychoanalysis and Art* (New York: Columbia University Press, 1986), p. 26. See also Barbara Johnson's discussion of how Mallarmé's "dynamic dramatization of the rhythm of pure difference" dismantles an economy of presence, in *The Critical Difference: Essays in the Contemporary Rhetoric of Reading* (Baltimore: Johns Hopkins University Press, 1980), pp. 13–20.

DEUXIEME LIVRAISON

DIMANCHE 20 SEPTEMBRE 1874

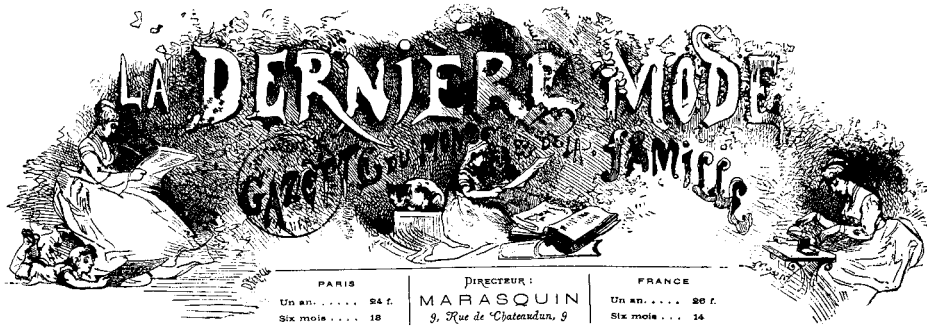

PARIS
Un an 24 f.
Six mois 18

DIRECTEUR :
MARASQUIN
9, Rue de Chateaudun, 9

FRANCE
Un an 20 f.
Six mois 14

PARAIT

LE 1^{er} ET LE 3^e DIMANCHE DU MOIS

AVEC LE CONCOURS

DES GRANDES FABRIQUES, DE TAPISSIERS-DÉCORATEURS, DE MAÎTRES GŒUX
DE JARDINIERS, D'AMATEURS DE BIJOUX ET DU SPORT

NOUVELLES & VERS

DE THÉODORE DE BANVILLE, LÉON CLADEL, FRANÇOIS COPPÉE, ALPHONSE DAUDET,
LÉON DIÈRE, ERNEST D'HERVILLE, ALBERT MÉRYAT, STÉPHANE MALLARMÉ,
CATULLE MENDÈS, SULLY PRUDHOMME, YVON VALADE, AUGUSTE VILLIERS DE L'ISLE ADAM,
ÉMILE ZOLA, ETC.

MUSIQUE

PAR LES PRINCIPAUX COMPOSITEURS



TOILETTES DE FROMENADE

Cover of La Dernière Mode, 1874.

system of deflections in which the luminosity of any single object is lost amid its indefinite reflections on the multiplied and fractured surfaces adjacent to it. The emerging world of fashion commodities and of life structured around their consumption revealed to Mallarmé a present impossible to seize hold of, an insubstantial world that seemed aligned with his own sublime disavowal of the immediate. At the same time *La Dernière Mode*, both in its titular concept and the internal movement of its text, is complicit with a naturalizing of fashion into a new seasonal and cyclical organization of experience, in which earliness and lateness acquire new meanings.⁸³ Mallarmé begins the fashion section of his first issue: “Too late to talk about summer styles and too early to speak of the winter ones (or even autumn ones).”⁸⁴ The abundance of material objects and experiences that are enumerated are finally no protection against an emptiness and anxiety at the heart of this impossible present. In this universe, there is no way to avoid being too early or too late, and to be out of style or “outmoded” is akin to death.

La Dernière Mode was preceded and perhaps to some extent precipitated by a more modest but equally revealing excursion by Mallarmé into the world of consumer culture. In the summers of 1871 and 1872, while in England, he wrote a series of short, pseudonymous articles reporting on the first two of the four London International Exhibitions (1871–1874).⁸⁵ The firsthand and clearly disorienting experience of a world’s fair, especially of the exhibits in the interior of the newly completed Royal Albert Hall, disclosed to him a smooth space on which the boundaries between the domains of art and industry had collapsed. Mallarmé does in fact characterize the proliferation of products on display within the historical problem of “decadence,” but there is a complete absence of Ruskinian censoriousness of manufactured shoddiness or any nostalgia for artisanal craft in his account. Instead, Mallarmé declares his intention to explore the new “double-sidedness” of modern commodities: the paradox that machine-made, hastily produced mass

83. “Good taste required one to distance oneself from the too-recent fashions of parvenus and demimondaines and the outdated fashions of the middle classes. For fashion could become a sign of an acceptable social standing only when one played with it skillfully, by choosing the appropriate place in the sequence between the excessively rapid innovation of eccentric fashions and the excessively slow tempo of ready-to-wear imitations.” Philippe Perrot, *Fashioning the Bourgeoisie: A History of Clothing in the Nineteenth Century*, trans. Richard Bienvenu (Princeton: Princeton University Press, 1994), p. 183.

84. Mallarmé, *Oeuvres complètes*, p. 711.

85. For another French account of this event see Eugene Muntz, “Les expositions de Londres,” *Gazette des Beaux-Arts* 6 (September 1872), pp. 236–249; (October 1872), pp. 312–325. See also the section on these London expositions in John Findling, ed., *Historical Dictionary of World’s Fairs and Expositions 1851–1988* (Westport, Conn.: Greenwood Press, 1990), pp. 44–47.

objects can nonetheless possess an aggregate aura that is as affecting as the aura of singular and rare objects of premodernity. Rather than lamenting the disintegration of an older model of authenticity, Mallarmé sees the delirious array of hybrid and historically eclectic products, such as clocks, armchairs, tapestries, lamps, mechanical toys, candelabras, dishware, perfume burners, pianos, even exotic live animals, as a tantalizing surface of experience.⁸⁶ “I predict the following: the word *authentic*, which was for many years the sacramental term of antiquarians, will no longer have any meaning.” What a joy, he continues, that “Grand Art” has been displaced from our domestic living spaces by “the irresistible virtue of Decoration itself.”⁸⁷ For Mallarmé the ocean of bric-a-brac he observed at the London exhibitions and the panorama of fashion commodities he detailed in *La Dernière Mode* were part of a compensatory decorative veneer both concealing and announcing the absolute vacuity at the heart of everyday life. The *distracted* quality of this unintelligible contiguity of styles, cultures, and forms was, for Mallarmé, a reprieve from a primal intuition of absence. Amid the implosion of the transcendental signifiers of religion or of the classical model of the artwork, the futility of attempting to locate anything stable or singular gives way to an immersion in the superficiality of modern fashion and decoration. Mallarmé saw even the polychrome exterior of the Albert Hall as the sign of a dematerialized architecture bereft of foundations and which corresponded to the exorbitant insubstantiality of the exhibits it enclosed. (Remarkably, he compared the optical effect of the structure to new industrial techniques of color lithography.)

Mallarmé’s immersions in the agitation of the expositions, entailing a perpetual deflection and dispersion of attention, finally becomes an affirmation of that very emptiness. Reporting on the London exposition, he pointedly noted the newsboys selling pamphlets titled “How to See the Exhibition in One Visit,” and he avowed his own inability to give more than a fragmentary account of the event and its aesthetic incoherence. In *La Dernière Mode* he outlined a related overload of possible diversions, pleasures, and spectacles. For Nietzsche, decadence is synonymous with the perceptual adaptability required by spectacular culture: “one loses one’s power of resistance against stimuli—and comes to be at the mercy of

86. However, the specific pseudonym chosen by Mallarmé for this writing assignment resonates with at least the muffled suggestion of despair over the general commodification of culture. The name, “L. S. Price,” phonetically seems to position the French interjection “*Helas*,” or English “*alas*,” next to the notion of the price tag.

87. Stéphane Mallarmé, “Exposition de Londres [1872],” *Oeuvres complètes*, p. 684.



PERFORMING TOYS.



THE AUTOMATON ZOUAVE.



THE WURTEMBERG REFRESHMENT STALL.



THE LLAMA.



A HUNDRED CARDS IN ONE MINUTE.

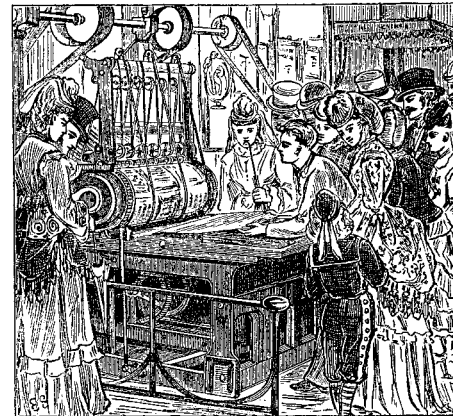

PRINTING THE "KEY."

SKETCHES IN THE INTERNATIONAL EXHIBITION.

Scenes from the 1871 London Exhibition, from The London Illustrated News.

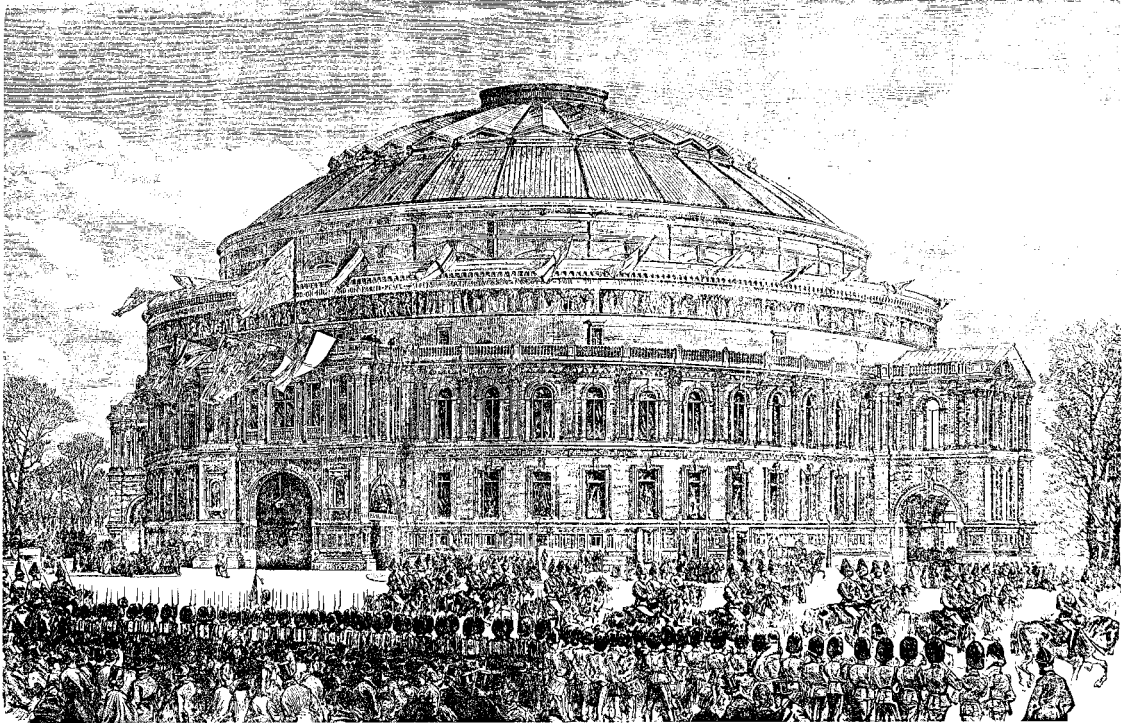

The Albert Hall at the opening of the 1871 London Exhibition.

accidents: one coarsens and enlarges one's experience tremendously."⁸⁸ For both Mallarmé and Nietzsche, decadence may kill existing capacities for action, for living, but at the same time it was an essential precondition for the emergence of new forms of life and invention. In Nietzsche's words, "Decadence itself is nothing to be fought: it is absolutely necessary and belongs to every age and every people."⁸⁹ In Mallarmé's eyes the pseudo-festival of the European expositions and the cosmopolitan milieu of *La Dernière Mode* were part of the "interregnum," the dead ground out of which might arise his own hoped-for ritual civic theater of the future and, as an implied consequence of such a cultural reform, an impossibly attentive observer-participant.⁹⁰ But in the meantime Mallarmé chronicled the

88. Friedrich Nietzsche, *The Will to Power*, trans. Walter Kaufmann (New York: Random House, 1967), p. 27.

89. *Ibid.*, pp. 25–26.

90. Recalling his work on *La Dernière Mode*, Mallarmé writes: "Basically I consider the contemporary

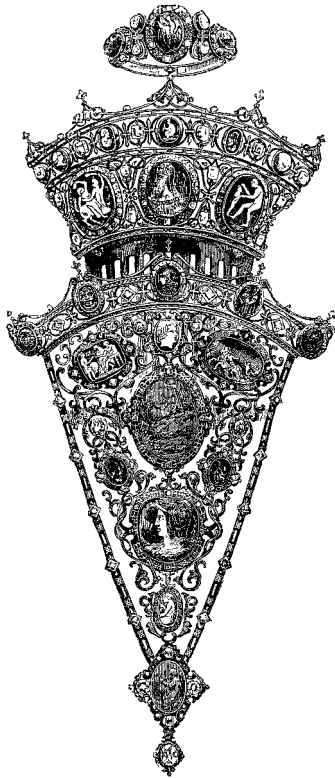

*British-made jewelry exhibited
at 1872 London Exhibition,
illustrated in Gazette des
Beaux-Arts, September 1872.*

dispirited spaces of his own present, which he counseled the poet “to stay out of,” perhaps occasionally delivering a “visiting card.” The first issue of *La Dernière Mode* began with a temporal characterization that could stand for the project as a whole: “dans cette saison de vacance.”⁹¹ For Mallarmé the bourgeois vacation of late summer 1874 was a window revealing a metaphysical condition of vacancy and its accompanying historical inertia.

The intersubjective space of *In the Conservatory* is a related revelation of a vacancy in the midst of perception. Manet, in his direct presentation of the fashion commodity, made visible what for Mallarmé remained more evanescent, but even

period as a form of interregnum for the poet, who has no business to get involved with it: it’s too obsolescent, too much in an effervescence of preparation, for the poet to have anything to do other than to work away mysteriously, thinking only of the future or of no time at all, and now and again send a visiting card to the living.” *Selected Letters of Stéphane Mallarmé*, trans. Rosemary Lloyd (Chicago: University of Chicago Press, 1988), p. 144; original in *Correspondance*, vol. 2, ed. Henri Mondor and Lloyd James Austin (Paris: Gallimard, 1965), p. 303; letter to Paul Verlaine, November 16, 1885.

91. Mallarmé, *Oeuvres complètes*, p. 719.

here the product is haunted by what Guy Debord describes as its inevitable displacement from the center of acclaim and the exposure of its essential poverty.⁹² Within this new system of objects, founded on the continual production of the new, attention, as researchers learned, was sustained and enhanced by the regular introduction of novelty.⁹³ This regime of attentiveness was synonymous with what Nietzsche described as modern nihilism: an exhaustion of meaning, a deterioration of signs. Attention became a necessary part of accounts of subjectivity because it seemed a means of salvaging or simulating experiences of singularity and identity in the face of processes of exchangeability and equivalence.

In a larger sense, the need for cognitive stability, fixation, and selection indicate the precariousness of a coherent subject position, and Manet's work demonstrates the impossibility of, for example, Janet's ideal of a normative synthesis in which the operation of vision effectively sustains the unified activity of the self.⁹⁴ *In the Conservatory* is poised at a boundary beyond which a functional vision would break down in a loosening of intelligibility and organization. Manet knew instinctively that the eye is not a fixed organ, that it is marked by polyvalence, by shifting intensities, by an indeterminate operation, and that a sustained looking at anything will relieve vision of its fixed character—that the eye can never exercise a “binding grip.” Instead his work persistently discloses the dissociation that would henceforth be synonymous with a modernized perception, regardless of whether that perception was deemed normal or pathological. Manet is the first modern artist to understand what would become crucial in the late work of Cezanne: the ways that an optical attentiveness can dissolve and disorganize the world, thus requiring a fundamental reconstruction of it by the artist. Gilles Deleuze, writing about what he calls “the special relation between painting and hysteria,” suggests that for the hysteric, objects are too present, and that an excess of presence makes representation impossible, and that the painter, if not restrained, has the capacity to extricate presences from representation.⁹⁵ For Deleuze the classical model of painting is a warding off of the hysteria that is so close to its heart.

92. Guy Debord, *The Society of the Spectacle* (1967), trans. Donald Nicholson-Smith (New York: Zone Books, 1994), p. 45 (sec. 69).

93. On the relation between attention and novelty, see, for example, John Dewey, *Psychology* (1886; New York: Harper and Brothers, 1889), pp. 126–127; and Leon Marillier, “Remarques sur le mecanisme de l'attention,” *Revue philosophique* 27 (1889), pp. 569–571.

94. Janet's normative model of the self “carries out a perception that synthesizes these two aspects, conscious and unconscious, under the form of an ‘I see.’” J.-D. Nasio, *L'hysterie ou l'enfant magnifique de la psychanalyse* (Paris: Rivages, 1990), p. 183.

95. Gilles Deleuze, *Francis Bacon: Logique de la sensation* (Paris: Editions de la difference, 1981), pp. 36–38. The paradoxical relation between representation and presence in painting is a major theme of

Thus *In the Conservatory* reveals Manet attempting to reclaim some of the terms of that classical suppression and restraint, of an obsolete model of synthesis.⁹⁶ It is a deeply ambivalent and disjunctive attempt, given his own intuitions of the disturbances inherent within perception. Perhaps the most notable feature of the painting that evades the state of enclosure, of being “in the grip” or “dans la serre,” is the tangled mesh of green behind the figures.⁹⁷ Is this what also fills the other side of the room, a possible object of the woman’s attention or distraction? Manet has applied the paint of the vegetation very thickly around the figures, rising up in an encroaching ridge around them, and thus the green is physically closer to our view than the figures themselves. This turbulent zone of color and proliferation exceeds its symbolic domestication and ceases to function as part of a figure/ground relationship. It suggests a perceptual order alien to the relations Manet has sought to freeze or stabilize around the two figures. It is a site on which attention is enfolded into its own dissolution, in which it can pass from a bound to a mobile state. It is along the continuity between these states that vision can become unhinged from the coordinates of its social determinants. And this is what Manet’s grip only imperfectly keeps in check—an attentiveness that would lose itself outside those distinctions.



Manet’s work in 1879 occurs within a larger field in which the uncertainties and malleability of attention were being tested and in which other organizations

Mallarme’s essay on Manet. If representation is to be exceeded, Mallarme suggests, a particular kind of attentiveness must be achieved: “The eye should forget all else it has seen, and learn anew from the lesson before it. It should abstract itself from memory, seeing only that which it looks upon, and that as for the first time; and the hand should become an impersonal abstraction guided only by the will, oblivious of all previous cunning.” Stephane Mallarme, “The Impressionists and Edouard Manet” (1876), in Penny Florence, *Mallarme, Manet, and Redon* (Cambridge: Cambridge University Press, 1986), pp. 11–18. This essay was originally published in English.

96. If one were to attempt a biographical reading of this painting, the question of binding, of finish, of holding things together takes on a particular pathos. In late 1878, the vague symptoms of ill health that Manet had experienced in the previous year or two culminated in an acute attack, which led to the diagnosis of syphilis and of the related condition of locomotor ataxia. We will never know conclusively whether this medical evaluation was correct, but what Manet suffered subjectively is clear and certainly conforms to how William James described the condition in a discussion of the inhibition of volition: “In locomotor ataxia, the representation of a movement and the consent to it take place normally. But the inferior centers are deranged and, although the ideas discharge them, they do not discharge them so as to reproduce the precise sensations anticipated.” James, *Principles of Psychology*, vol. 2, p. 560. For an artist of Manet’s extraordinary manual virtuosity, that initial, fearful sense of a dissolution of the link between thought and motor control might have been met with an anxious return to an earlier model of a world more tightly bound together, as a symbolic protection against the appalling deterioration of that control.

97. On the structural importance of the color green in Manet’s work, see Gisela Hopp, *Edouard Manet: Farbe und Bildgestalt* (Berlin: Walter de Gruyter), 1968, pp. 54–58, 116–113.



Max Klinger, Place: Glove Cycle, 1879, detail.

of perceptual binding and synthesis were taking shape. Consider Max Klinger's *Glove* cycle, a work that develops within much the same narrative circumstances as Manet's painting: the uncertain public interactions and self-presentations of fashionably dressed men and women in new leisure-time environments.⁹⁸ However, this work is determined by a very different libidinal setup and, as a series of images, obviously constitutes another category of perceptual dispersion. A detail of Klinger's first print depicts an analogous configuration, a seated woman attended to by a male figure. This is the woman whose abandoned glove precipitates the psychic odyssey recounted in the cycle. The gloves belonging to Manet's woman on the bench (and other potential sites of fixation in *In the Conservatory*) have none of the overloaded investment that the glove has in Klinger, where attentiveness overruns any normative synthesis to become exclusively determined by a single content. In orthodox psychoanalytic terminology it might be possible to designate *In the Conservatory* as a "neurotic" image that would be the flip side of the "perversion" of the *Glove* cycle. As Michel Foucault has shown, by the late

98. The first etched edition of this cycle appeared in 1881, although the ink drawings were exhibited in 1878. See Christiane Hertel, "Irony, Dream and Kitsch: Max Klinger's *Paraphrase of the Finding of a Glove* and German Modernism," *Art Bulletin* 74 (March 1992), pp. 91–114.

1870s fetishism had become the preeminent example of all the perversions.⁹⁹ In contrast to the absence of any overt fixation of desire in the Manet, the Klinger series expresses explicitly what would be repressed in neurosis.¹⁰⁰ In Klinger's cycle, vision, although obsessively bound and focused on the detached element of the glove, at the same time unravels into serial and metamorphic movements. It traces a shifting path from image to image, adjacent to that emerging social landscape on which flows of desire and the circulation of commodities will ceaselessly overlap. It is a path on which the boundaries between dream, hallucination, and "normal" perception are suspended. Attention, riveted on the absence denoted by the glove, that is, on "the container instead of the thing contained," deliriously opens out as a dynamic and productive process.¹⁰¹ Klinger prefigures some of the hypotheses in *The Interpretation of Dreams* where Freud is still testing his equation of psychical energy and "mobile attention," which had been central to the "Project for a Scientific Psychology."¹⁰² The work of Klinger and Freud each affirm the inseparability of attention from both the dream process and aesthetic production.

In a brief historical aside in his book on cinema, Gilles Deleuze notes that the crisis of perception in the late nineteenth century coincides with the moment at which it was no longer possible to hold a certain position, and he indicates the wide range of factors that introduced more and more movement into psychic life.¹⁰³ It is hardly insignificant that the first two images in the *Glove* cycle are of roller skating: the observer as a kinetic seeing body set in motion, to glide along undetermined social and durational trajectories. Part of the persistent appeal of the most famous print in the series is its very kinesthetic quality, which seductively endows the diverging physical movement of the roller skaters with an involuntary, fluid somnambulance—it becomes a frictionless dream space, sealed in by the dense and impossibly lush wall of vegetation behind the gliding skaters, with none of the actual shocks, breaks, and interruptions of contemporary urban

99. Michel Foucault, *History of Sexuality*, vol. 1: *An Introduction*, trans. Robert Hurley (New York: Random House, 1978), p. 154.

100. See Sigmund Freud, *Three Essays on the Theory of Sexuality*, trans. James Strachey (New York: Basic Books, 1975), pp. 26–33.

101. The quotation is from the discussion of Klinger in John Ashberry, "The Joys and Enigmas of a Strange Hour," in Thomas B. Hess and John Ashberry, eds., *The Grand Eccentrics* (New York: Collier, 1966), pp. 25–31.

102. See Freud, *The Interpretation of Dreams*, pp. 134–135.

103. Gilles Deleuze, *Cinema: The Movement-Image*, trans. Hugh Tomlinson (Minneapolis: University of Minnesota Press, 1986), p. 56.

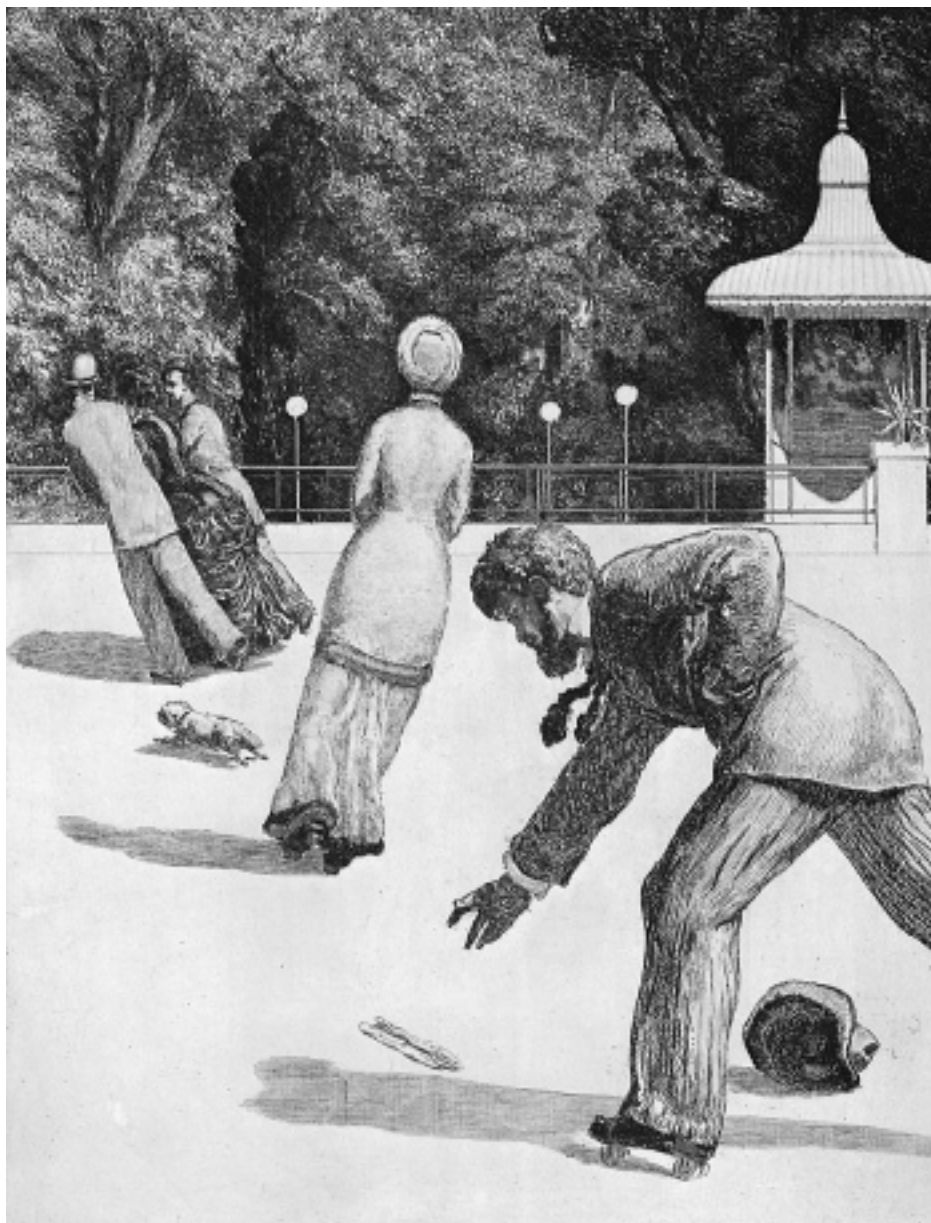

Max Klinger, Action: Glove Cycle.

experience.¹⁰⁴ In 1877 Manet had represented a related entertainment site, the ice skating rink on the Rue Blanche, in his painting *Skating*. The public greenhouse and the skating rink were two of what Benjamin called “dream spaces,” new social arenas that demanded an ambulatory visual consumption and that provided the possibility for previously unknown libidinal encounters and itineraries.

The first print, “Place,” may be the single richest unit in Klinger’s series. Few other images of this time are so pregnant with the ordinary anxiety, the expectancy, the sublimated precariousness of a modernizing urban world in which the individual is adrift on a smoothed-out surface devoid of any enduring markers. The appearance of stasis is undermined throughout, not only by the obvious symbol of the roller skates and the young girl who has fallen down, but by the network of glances and gestures that anticipate, that already accommodate the dislodgings and vagrancy of sexual and social certainties. Homoerotic desires intermingle here as the bound model of the heterosexual couple is displaced by the prospect of new transient configurations (which take explicit shape in the ambiguous trio of skaters in the second print). One of Klinger’s achievements here was to find a means of formalizing effects of social fragmentation and psychic dissociation while preserving the naturalist surface of the image.¹⁰⁵ In the wall of windowpanes, the misalignment of the individual panes prevents the glass surface from intelligibly reflecting the scene before it. Instead, the indecipherable reflections on the grid of panes become an unsettling assemblage of isolated and disjunct mirrorings of the milieu inhabited by the prosthetically mobilized figures. In a related way, the additive accumulation of figures is defamiliarized through movements and interactions

104. The growing popularity of skating as an urban leisure activity by the early 1870s is attested to by an addition made to the 1872 edition of Herbert Spencer’s *Principles of Psychology* (first published 1855). Discussing the origins of aesthetic sentiments, he writes: “Movements of the body pleasurable to self and associated with the consciousness of gracefulness, as in skating, are movements of a kind that bring many muscles into moderate harmonious action and strain none.” Spencer, *Principles of Psychology*, 3d ed., vol. 2 (New York: D. Appleton, 1872), p. 639. See also the example of movement on a skating rink within a discussion of peripheral and unconscious attentiveness in Wilhelm Dilthey, *Introduction to the Human Sciences*, ed. Rudolf A. Makkreel and Frithjof Rodi (Princeton: Princeton University Press, 1989), pp. 308–309.

105. Kirk Varnedoe situates Klinger’s work within “an unstable strain of later realism” in the late 1870s and 1880s, which also included the art of James Tissot and Gustave Caillebotte: “It is a vision not given over to overt abstraction of structure in the manner of Degas. Instead it is a stylistic inflection that is aware of photography in a special way, using relatively normative viewpoints but frequently embodying an undercurrent of tension between seeming mundane objectivity and selected devices of expressive composition.” He also identifies “a sensitivity to reverie and/or boredom . . . for the inactivity of the leisure classes, whereby rigidity becomes expressive of life-condition in a way that prefigures Seurat.” J. Kirk T. Varnedoe, “Caillebotte: An Evolving Perspective,” in *Gustave Caillebotte: A Retrospective Exhibition* (Houston: Museum of Fine Arts, 1976), pp. 47–59. I would only add that Manet’s *In the Conservatory*, and especially the woman on the bench, can usefully be linked with these features.

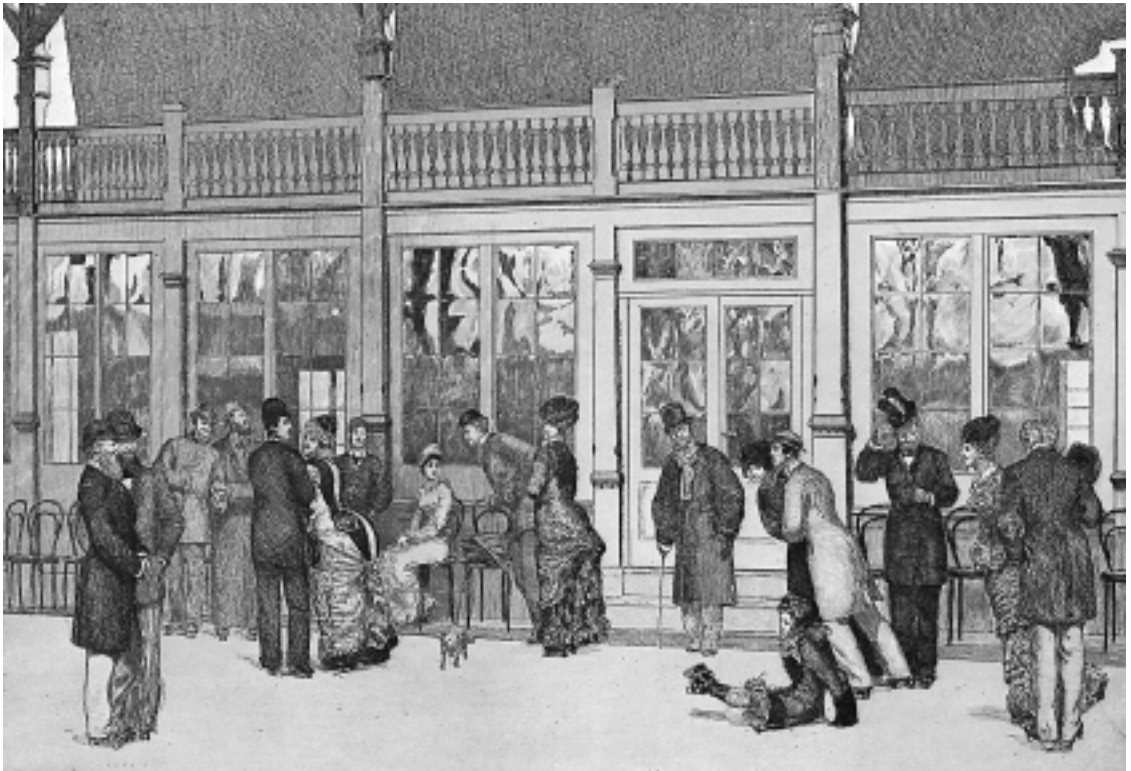

Klinger; Place: Glove Cycle.

that are temporally staggered and disconnected. There is a subtle rift between actions and reactions, glances and attractions, heightening the disunity of the image.¹⁰⁶

Klinger's alternate title for the second print was "Sachverhalten," loosely translatable as "the facts of the case." This generalized institutional resonance (suggesting the bureaucratic and legal rationality of Germany in the 1870s rather than a later notion of a medico-psychiatric "case") serves to situate the image as part of a detective story, a policier of some kind, in which clues or traces are being intently sought. The first image, which had the alternate French title "Preamble," establishes the milieu in which this quest occurs: a seemingly random aggregation of individuals that is a tangle of relations to be deciphered, objects of significance

106. See the valuable analyses of the first two *Glove* prints in J. Kirk T. Varnedoe, *Graphic Works of Max Klinger* (New York: Dover, 1977), pp. xiv–xxii.



Max Klinger, Anxieties: Glove Cycle.

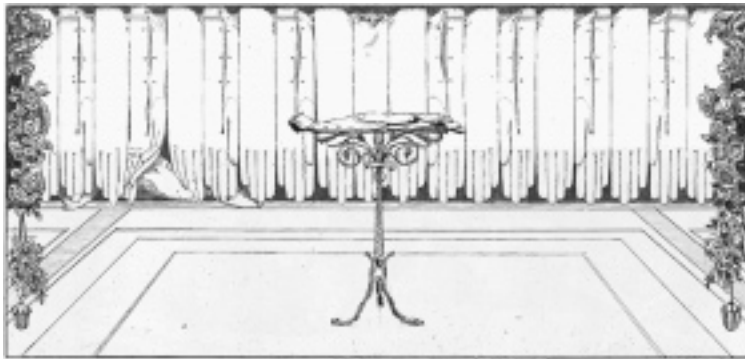

Max Klinger, Silence: Glove Cycle.



Max Klinger, Rescue: Glove Cycle.



Max Klinger, Abduction: Glove Cycle.

located and perceptually isolated. With the move from the first to the second print, then, a field of content is suddenly narrowed by the selective activity of attention. The skater (Klinger depicts himself) who bends over the fallen glove embodies the overlapping figures of detective, collector, consumer, and fetishist. The proximity of these roles and their specifically modern forms of obsessiveness highlight the ambiguous boundaries that separate an intense focused attentiveness from monomania, *idees fixes*, fetishism, or any number of other “pathological” disorders of attentiveness.¹⁰⁷ At the same time the “perversion” at the heart of a quest for facts, for truth, is made evident. In one of the subsequent prints in the cycle, “Silence,” the glove sits atop an ornate table as part of an ostentatious display, in which it seemingly could be a collectible, fetish object or luxury commodity. But the *Glove* cycle is based on a *monoideisme* that exceeds the normative attentive adaptability required to sustain consumer culture. In Klinger’s work fixations have become indefinitely extended and therefore “sociopathic,” in contrast to an attention span of limited duration that can continually reselect and reorient itself to the endless debut of new products and spectacular objects of consumption. Klinger also shows, as Freud outlined in *Interpretation of Dreams*, that when attention isolates a particular content from a larger cognitive field, the act of dissociation can be the initiation of a *productive* process. But finally the seriality of Klinger’s cycle is structurally consistent with the texture of an emerging mass visual culture and its many manufactured forms of “realism.”

Two years after *The Glove* was published in 1881, the city of Berlin witnessed the opening of a new visual attraction in the Passage “Unter den Linden” that was a model of another pervasive experience of imaginary production. The ex-scientist, then optical entrepreneur August Fuhrmann devised a mechanical viewing apparatus, called the Kaiserpanorama, for the public (and profitable) display of his immense collection of glass stereoscopic photographs.¹⁰⁸ That Fuhrmann labeled his work a “panorama” has misled a number of historians and critics to

107. “It is well, in the first place, to observe that there is an almost insensible transition from the normal state to the most extravagant forms of the fixed idea. Everybody must have experienced what it is to be haunted by a musical air, or some insignificant saying, that obstinately keeps coming back without any visible reason.” Theodule Ribot, *La psychologie de l’attention* (Paris: F. Alcan, 1889), p. 76.

108. See Stephan Oettermann, *The Panorama: History of a Mass Medium*, trans. Deborah Schneider (New York: Zone Books, 1977), pp. 229–232; idem, *Das Kaiserpanorama: Bilder aus dem Berlin der Jahrhundertwende* (Berlin: Berliner Festspiele, 1984); and Ernst Kieninger and Doris Rauschgatt, *Die Mobilisierung des Blicks* (Vienna: PVS Verlager, 1995), pp. 51–58. For some of the technical details of the Kaiserpanorama, see Paul Wing, *Stereoscopes: The First One Hundred Years* (Nashua, N.H.: Transition, 1996), pp. 232–233.

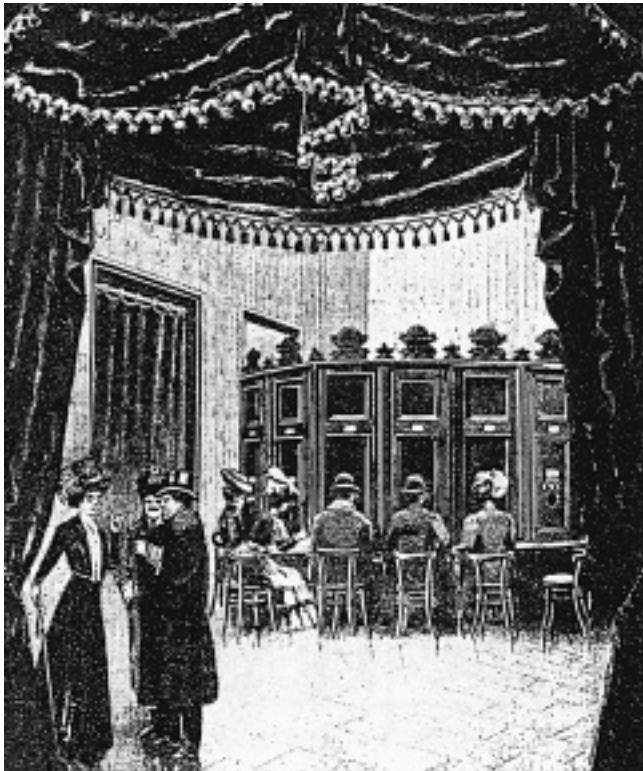
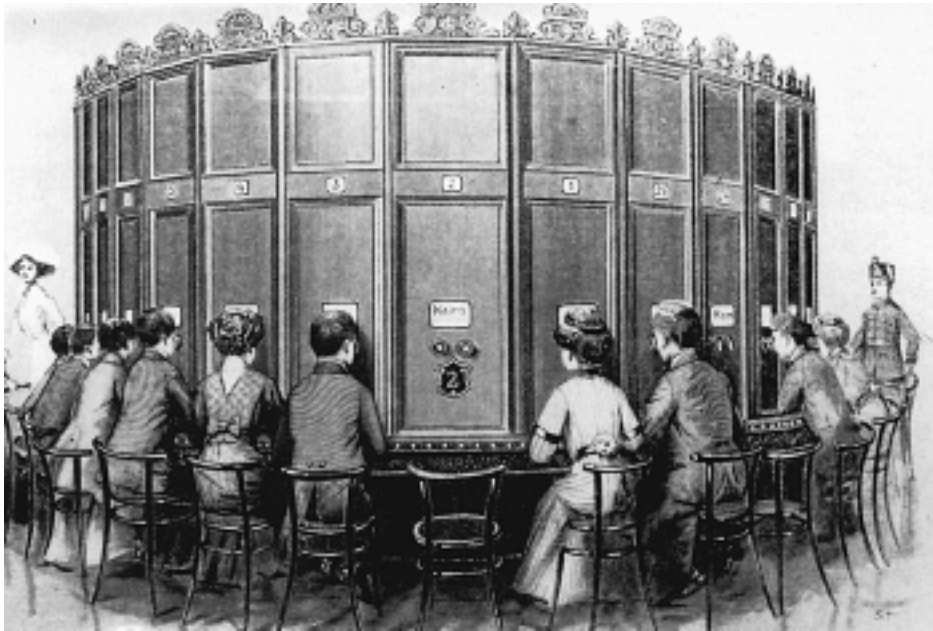

*Two views of
the original
Kaiserpanorama,
Berlin, 1880s.*

assume that it was somehow part of the nineteenth-century development of panorama painting and display. Except for the fact that its form was circular, it had no technical or experiential connection to the panorama proper. No doubt Fuhmann used the word for its association with the highly popular and long-established attraction, but also in another sense that the word came to acquire during the nineteenth century: a sweeping, comprehensive view (even if attained through a succession of many views). Stephan Oettermann has pointed out that the Kaiserpanorama (or Weltpanorama, as it was renamed after World War I) was a hybrid apparatus that was essentially a stereoscopic peep show. It was, in effect, a large-scale multiviewer version of the enclosed Brewster-model stereoscopes that became widely popular in the 1850s. But by employing transparent and color-tinted glass slides, Fuhmann also provided some of the features (on a miniature scale) that were associated with Daguerre's original diorama: illusory three-dimensional scenes whose reality effects were augmented by concealed lighting and translucent paintings. Fuhmann was soon able to mass-produce the Kaiserpanorama, and there were as many as 250 in operation in cities in Germany, Austria, and elsewhere. A number of these were built on a smaller scale than the original in Berlin, some with places for only six spectators.

In one sense the history of the Kaiserpanorama belongs within that of the stereoscope and peep show, but its particular structure foreshadows the experience that Edison provided with his Kinetoscope in the early 1890s, that is, an individual viewing station located in a public place, for which a consumer would pay to observe a mechanized series of photographic images. Obviously the Kinetoscope was historically significant for its exhibition of moving images, but common to both devices is a specific conception of how an audience could be organized in terms of an individual machinic engagement and of an economic consumption in which both hardware and software would be owned by an operator-entrepreneur. The first Kaiserpanorama was about fifteen feet in diameter and could accommodate 25 spectators, who would simultaneously be viewing different stereoscopic images illuminated by 25 small lamps. The interior contained a motor that rotated the slides at roughly two-minute intervals from viewer to viewer. A bell would ring just as the slides were about to change. Thus, if the consumer chose, the experience could last up to fifty minutes—a long period of immersion in this world of seemingly three-dimensional views of both local and far-off scenes, complete with descriptive titles.¹⁰⁹ By the 1890s, however, Fuhmann

109. As the Kaiserpanorama grew in popularity, the need for new images (or software) intensified. Fuhmann sent teams of photographers throughout Europe and across the world to bring back images

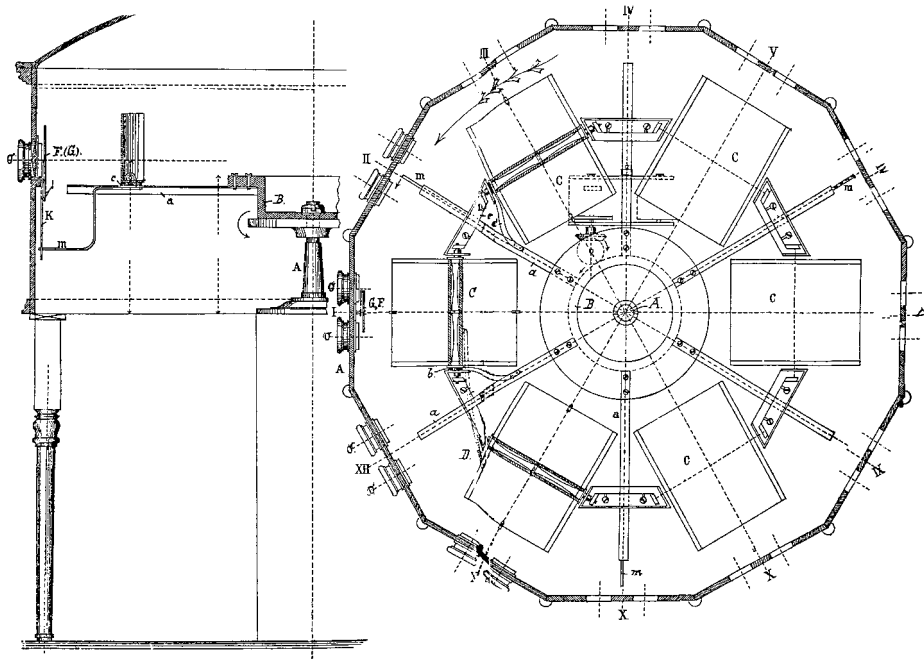

Plan and cross section of Kaiserpanorama, from Furbmann's application for a British patent, 1890.

retooled the device, equipping it with individual coin slots at each viewing station, allowing the individual consumer to determine the duration and cost of optical engagement.

In contrast to the libidinally determined mix of fixation and meandering in Klinger's work and the transformations it unleashed, the Kaiserpanorama was one of many visual apparatuses for *mechanically* sustaining attention while

of exotic locales in what Oettermann calls the "visual equivalent to the political imperialism of the age." Newspaper ads solicited spectators with the slogan "Reisen durch die ganze Welt." It should be remembered that in the period between 1883 and 1886 Germany acquired all of her colonies in South-west Africa, East Africa, and the Pacific. 1882 was the year of the founding of the Society for German Colonization. See Hans-Ulrich Wehler, *The German Empire 1871–1918*, trans. Kim Traynor (Hamburg: Berg, 1985), pp. 170–176. Dolf Sternberger remarks that the vogue for scenes of German colonization in the 1880s occurs in part because "the views from European windows had lost their depth, becoming part and parcel of the same panorama world surrounding them and constituting a painted surface everywhere." He discusses images of Africa exhibited in the related Kaiser Diorama as part of the Jubilee Exhibition of the Berlin Academy of the Arts in 1886 in his *Panorama of the Nineteenth Century*, trans. Joachim Neugroschel (New York: Urizen, 1977), pp. 46–47. See also the discussion on the relation between tourism and late nineteenth-century forms of visual consumption in Anne Friedberg, *Window Shopping: Film and the Postmodern Condition* (Berkeley: University of California Press, 1994), pp. 15–29.

simultaneously introducing variation externally. The Kaiserpanorama is one of the numerous sites on which we can credibly locate an “industrialization” of visual consumption: it is a space in which the physical and temporal alignment of body and machine correspond to the rhythms of factory production and to the way in which novelty and interruptions were introduced into assembly-line labor in order to prevent attention from veering into trance and daydream. But it is also a structuring of experience common to many precinematic devices in the 1880s, and then to cinematic ones in the 1890s, in which the fragmentation of perception inherent to the apparatus is at the same time presented in terms of a mechanically produced continuum that “naturalizes” the disjunctions. (By what logic of temporal sequence or spatial continuity does one move from the interior of the papal apartments in Rome to the Great Wall of China to the Italian Alps at 120-second intervals?) Whatever subjective psychological investment is in play (as desire, dream, reverie, fascination), it is inseparable from a machinic tempo within which the idea of switching attention must seem necessary and inevitable. It is not possible to associate unproblematically a device like the Kaiserpanorama with a category of easily consumable “realism.” Rather it is one of many places in which an *automation* of perception occurs, in which synthesis is mandatory, an automation that continues unabated along other lines today.¹¹⁰



A related and more consequential remaking of perception occurs in the 1878–1879 experiments of Eadweard Muybridge that produced his first successful sequential photographs of moving horses. What Muybridge achieved around 1879 was a reorganization and dispersal of perception that exposed not the naturalness of vision but, as Noel Burch and others have insisted, its systematic and constructed character.¹¹¹ The first images from Palo Alto in 1878 retain something of their original disruptiveness, and perhaps are finally more disturbing than anything done by Etienne-Jules Marey. Unlike Muybridge’s, the work of Marey was based

110. Herbert Spencer had provided an influential insistence on the centrality of perceptual synthesis to normative psychological life: “Mental actions, ordinarily so-called, are nearly all carried on in terms of those tactual, auditory, and visual feelings which exhibit cohesion and consequently ability to integrate in so conspicuous a manner. . . . The most developed portion of perceptive Mind is formed of these visual feelings which cohere so rigidly, which integrate into such large and numerous aggregates immensely exceeding in their degree of composition all aggregates formed by other feelings.” Spencer, *Principles of Psychology*, 3d ed., vol. 1 (New York: D. Appleton, 1871), p. 187. This passage was cited in John Hughlings Jackson, “On the Nature of the Duality of the Brain” (1874), parts I and II, ed. Henry Head, *Brain* 38 (1915), pp. 87–95.

111. Noel Burch, *Life to Those Shadows*, trans. Ben Brewster (Berkeley: University of California Press, 1990), p. 11.



Colored glass stereoscopic photographs for display in the Kaiserpanorama: Niagara Falls, Japanese women, and a London street scene.

on a reciprocal operation of decomposition and reunification: his analysis of movement, within the frame of a single visual field, preserved a vector of spatial and temporal coherence, giving to movement a *new form* of legibility and rationality, even if through unprecedented representational practices. Muybridge conducts a more intransigent and blunt dismantling of the apparent continuities of movement and of time, and his work is one instance of a larger decoupling of empirical verisimilitude from a “reality effect.” Also his images did not as easily lend themselves to an aestheticizing appropriation as Marey’s work. No relations of causal necessity link the positions or sections that are presented in sequence, only an imprecise and disjunct sense of before and after. Hence those who criticize Muybridge as being less “advanced” than Marey because he did not introduce the variable of time into his work are thinking in terms of an impoverished model of time. The breakthrough of Muybridge’s work in 1878 was its deployment of machinic high speeds for the creation of perceptual units beyond the capacities of human vision, and their subsequent abstract arrangement outside the terms of any subjective experience.¹¹² Muybridge, with his modular segmentation of images, breaks down the possibility of a “truthful” syntax, and his aggregate presentations set up an atomized field that an observer cannot seamlessly rebind. But the apparent nonhomogeneity and segmentation of his work are actually an opening onto an abstract order of continuities and uninterrupted circuits.

The circumstances of Muybridge’s early motion studies are inseparable from the figure of Leland Stanford, the innovative and ruthless California financier.¹¹³ It was Stanford, by then an ex-governor and wealthy racehorse owner, who first proposed the experiments with which Muybridge almost coincidentally happened to become involved. Stanford, as a founder and director of the Central Pacific Railroad, is tied to a key process of capitalist modernization in the mid-nineteenth century: the installation of railroad transport and steamship routes as part of a specific historical phase in the reduction of the time and cost of *movement*, as an acceleration in the flow of circulating capital, and as an expression of the imperative “to reduce to a minimum the time spent in motion from one place to another.”¹¹⁴ Marx insisted that “capital by its nature drives beyond every spatial

112. To avoid any misunderstanding here, my discussion about Muybridge concerns his work of 1878–1879 and not his subsequent work at the University of Pennsylvania in the mid-1880s that produced *Animal Locomotion*.

113. On Stanford, see Matthew Josephson, *The Robber Barons: The Great American Capitalists 1861–1901* (New York: Harcourt, Brace, 1934), pp. 81–89, 217–230.

114. Karl Marx, *Grundrisse*, trans. Martin Nicolaus (New York: Random House, 1973), p. 539. The actions of Stanford and the Central Pacific group coincide with the logic described by Marx here.

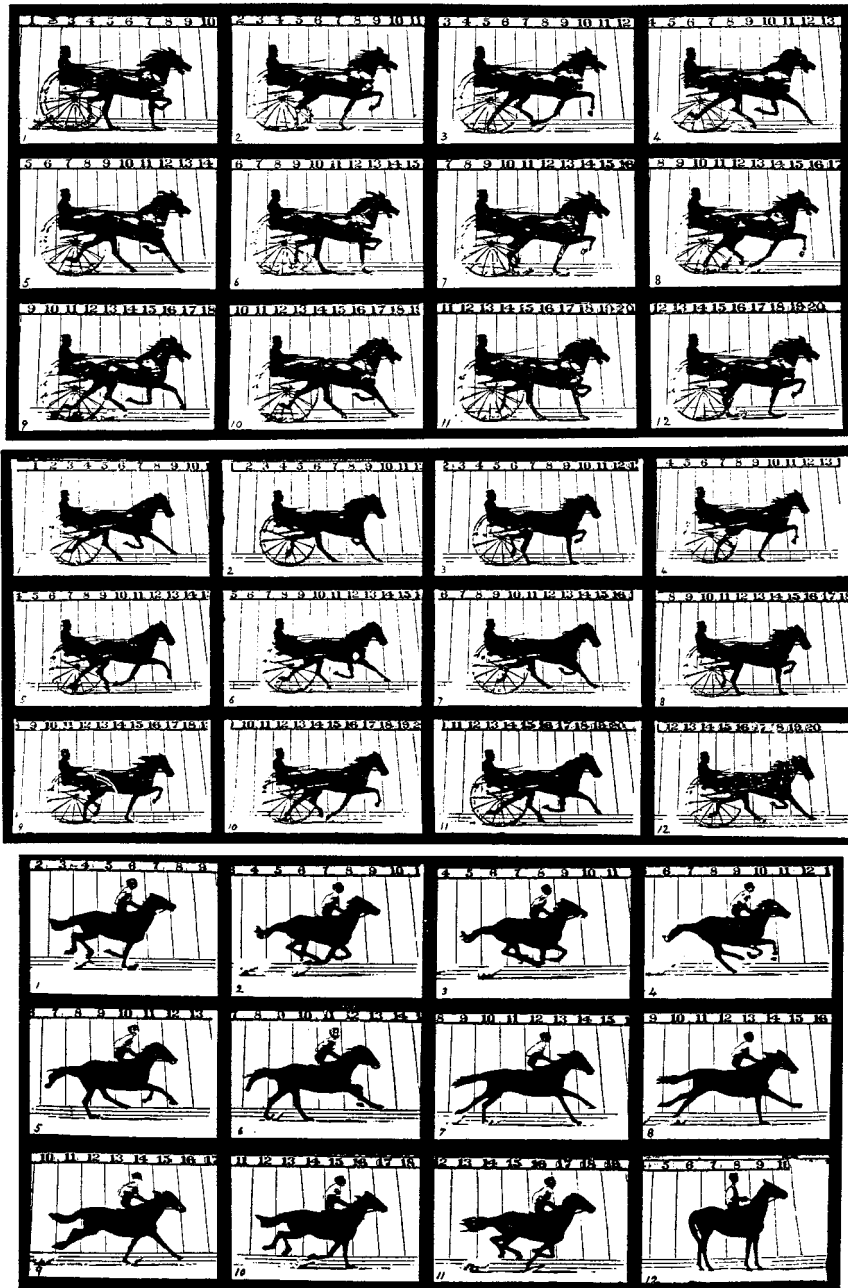

Fig. 3. Trot. 715 mètres à la minute. — Fig. 4. Trot 727 mètres à la minute. — Fig. 5. Galop. 1142 mètres à la minute.

Eadweard Muybridge, The Horse in Motion, as reproduced in La Nature, 1878.

barrier. Thus the creation of the physical conditions of exchange—of the means of communication and transport—the eradication of space by time—becomes an extraordinary necessity for it.”¹¹⁵ The identification of *means of communication* here is crucial; obviously Marx is referring to early forms of telecommunication like the mail system and telegraph, which would lead to the ubiquity of instantaneous forms of communication in the twentieth century.¹¹⁶ But implicit in the modernization of these forms is the parallel renovation of perception and information, such as the photographic experiments of Stanford and Muybridge. They are one of the sites of a related reduction in the time of perception so that visuality would coincide with the speeds and temporalities of both circulation and telecommunication. Just a few years later, in the early 1880s, Ernst Mach began his experiments photographing a bullet in flight at velocities exceeding the speed of sound. Mach was able not only to isolate an image of the projectile from its trajectory but at the same time to record the shock waves traveling just *ahead of it*, thus suggesting some of the radical rearrangements of perceptual “truths” made possible by machinic speeds. Such photographs overturned conventional cognitive assumptions about cause and effect and defamiliarized the apparent nature of a physical “event.”

The segmentation of Muybridge’s work should be understood not simply as the breakup of a perceptual field but also as the claiming of an instantaneity of vision from which space is deleted. It announces a vision compatible with the smooth surface of a global marketplace and its new pathways of exchange. Muybridge seems to present the semblance of a classical tabular organization, but what is arrayed in his rows and columns has none of the immutable identities on which the intelligibility of a table depends.¹¹⁷ *The Horse in Motion* has to be understood as an uprooting of perception from any stable space-time coordinates. Muybridge’s work is a significant instance of what Deleuze and Guattari described as processes of capitalist deterritorialization and decoding—infelicitous terms perhaps, but they suggest how anything with a permanent stable location in space is incapable of being inserted into a system of exchange and circulation and how anything that is part of a code (a traditional or established pattern of behavior or representation)

115. Marx, *Grundrisse*, p. 524. See the discussion of this section of Marx’s text in David Harvey, *The Limits to Capital* (Chicago: University of Chicago Press, 1982), pp. 376–386.

116. For a discussion of capitalism and the nineteenth-century origins of modern communication networks, see Armand Mattelart, *La communication-monde: Histoire des idées et des stratégies* (Paris: Editions la découverte, 1992), pp. 1–56.

117. On classical tabular order, see Michel Foucault, *The Order of Things* (New York: Pantheon, 1971), pp. 50–76.

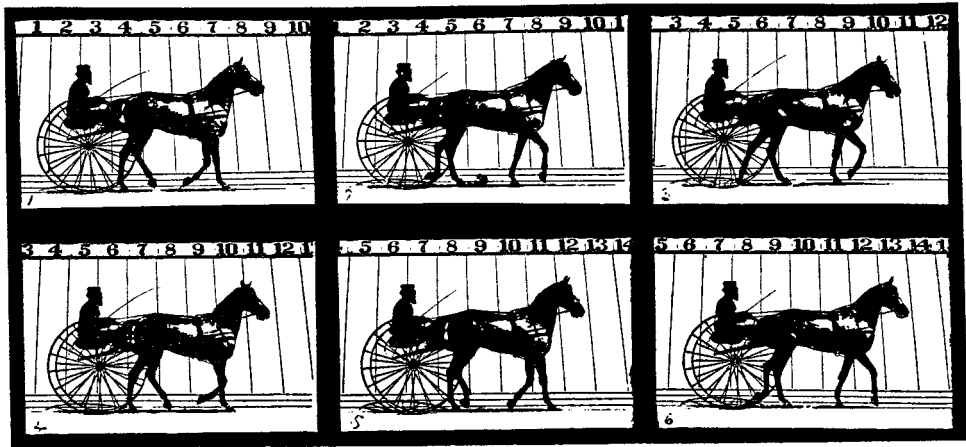

Fig. 1. — Cheval au pas. — 103 mètres à la minute.

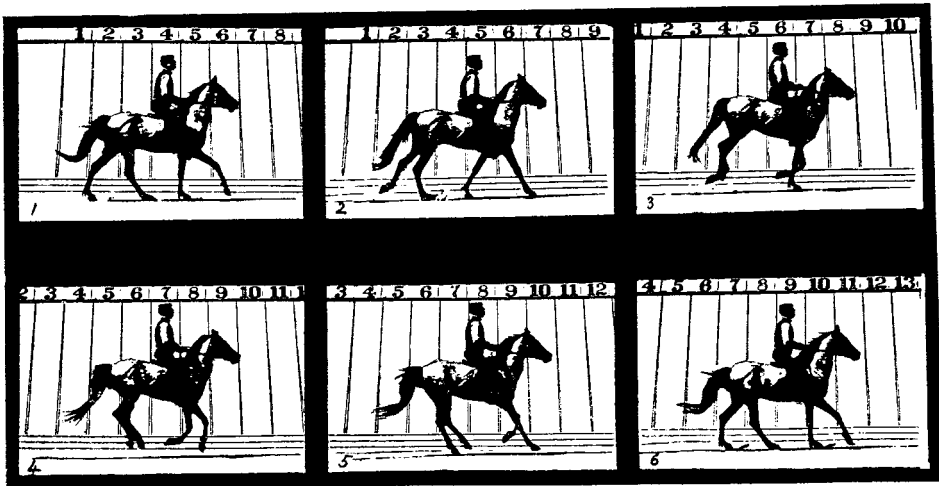
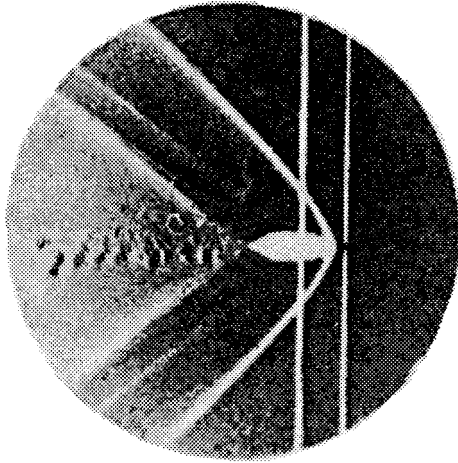

Fig. 2. — Petit galop. — 200 mètres à la minute. (Reproduction par l'héliogravure de photographies instantanées.)

Muybridge, The Horse in Motion, as reproduced in La Nature, 1878.



Ernst Mach, photograph of a projectile traveling at 520 meters per second, mid-1880s.

will resist being deployed in networks of abstract relations. The history of capitalism is the history of overcoming these obstacles to its effective operation. The ideal of instantaneous and automatic machinic perception, which Muybridge's fast shutters at least suggested, was a set of capabilities that fully exceeded the impoverished limits of human vision and attention. What became important in the 1880s, according to François Dagognet, "was eliminating the human intermediary, a screen that complicated, distorted, and prevented access to reality."¹¹⁸ But in spite of perceptual "inadequacies," human subjects would nonetheless be increasingly defined in terms of such models, for example in the study and measurement of reaction time as part of the determination of behavioral norms. And the horse, which had been for thousands of years the primary mode of vehicular movement in human societies, is symbolically dismantled into quantified and lifeless units of time and movement.

The perceptual temporalities opened up by Muybridge in 1878 are more fully understood when seen alongside some of his lesser-known photography from just a few years earlier. In 1875 he was engaged by the Pacific Mail Steamship Company, recently acquired by financier Jay Gould, to make an extended photographic tour of Central America.¹¹⁹ The company wanted publicity images to help "stimu-

118. François Dagognet, *Etienne-Jules Marey: A Passion for the Trace* (New York: Zone Books, 1992), p. 43.

119. Gould had purchased Pacific Mail Steamship in collusion with Stanford and Collis Huntington in order to insure that marine shipping rates would never undercut those of the railroads. See the revealing chapter on "The Gould System" in Robert Edgar Riegel, *The Story of the Western Railroads: From 1852 through the Reign of the Giants* (1926; Lincoln: University of Nebraska Press, 1964), pp. 160–178.

late Central and South American commerce, and to interest capitalists and tourists in visiting the countries of the area,” but it also instructed Muybridge to make photographs of the Guatemalan coffee plantations as a way of attracting new investment in the coffee industry.¹²⁰ Thus in the final album images of productive labor intermingle with representations of Central America as a tranquil “earthly paradise.” Of the many remarkable images which Muybridge produced in Guatemala I will discuss only one, of workers gathering and packing beans under mid-day clouds in the rolling hills of the Las Nubes coffee plantation.¹²¹ This photograph presents a fraudulently homogenous and static image of elements (bodies and land) which have become quantified and exchangeable, part of an unstable system incapable of immobilization. It discloses the antinomic coexistence of living labor power (with its irreducible existential temporalities) and the tendency of capital to “circulation without circulation time.”¹²² The violence and social devastation underlying this all-over distribution of human beings within the lush vegetation of this apparently premodern landscape is the consequence of the same imperatives of modernization which impelled Muybridge’s Palo Alto experiments, which would initiate a ceaseless analysis of the ways the body and its motions could be rendered productive. Like Stanford’s horses in motion, this image of Central America is a static section of movements and trajectories whose abstraction and velocity are also outside of the human capacity to perceive them. The destiny of these workers is fully part of the same processes.

120. I am relying on the account of this trip in E. Bradford Burns, *Eadweard Muybridge in Guatemala, 1875* (Berkeley: University of California Press, 1986), as well as the relevant sections in Robert Bartlett Haas, *Muybridge: Man in Motion* (Berkeley: University of California Press, 1976), pp. 79–81, and Gordon Hendricks, *Eadweard Muybridge: The Father of the Motion Picture* (New York: Grossman Publishers, 1975), pp. 81–95. “But now the trip’s *raison d’être* was at hand—the great coffee plantations of San Mateos, Las Nubes and San Felipe. The coffee industry had been in the doldrums . . . but President Berrios decided to reactivate coffee. The government had granted sweeping privileges to new entrepreneurs, as well as to established plantation owners, and the industry was on its way. It was perhaps the hope of attracting new investments that had persuaded the Pacific Mail Steamship Company, which had a virtual monopoly in the trade, to commission Muybridge to photograph *points of interest* in Central America.” Hendricks, *Eadweard Muybridge*, p. 84; emphasis added.

121. Muybridge, on completion of seven months of work, announced through a newspaper ad that prints of his Guatemala photographs could be purchased: “I have the pleasure of informing you that I have formed a collection which includes the most notable public buildings, the most picturesque localities, and the most natural scenes of cultivation and agricultural products. All this is due to the Pacific Steamship Company which has assumed the costs of this venture for the purpose of making the riches and beauty of this interesting land known abroad.” Cited in Hendricks, *Eadweard Muybridge*, p. 85. This is an exemplary statement of the optics of nineteenth-century colonialism, in which what is visible to Muybridge is either an administrative infrastructure or picturesque *views* or *natural resources* to be extracted for the benefit of those “abroad.” Despite the self-evident presence of native workers on the coffee plantations, they remain invisible except as abstract components within flows of capital or as “naturalized” elements within an imaginary landscape.

122. Marx, *Grundrisse*, p. 671.



Eadweard Muybridge, Picking Coffee at Las Nubes, Guatemala, 1875.

Siegfried Kracauer insisted that modern historiography, as it took shape in the nineteenth century, was inseparable from the invention and spread of photography. Camera-reality, he wrote, “has all the earmarks of the *Lebenswelt*. It comprises inanimate objects, faces, crowds, people who intermingle, suffer, and hope; its grand theme is life in its fullness, life as we commonly experience it.”¹²³ Roland Barthes, in a related way, detailed how the photograph can operate as part of a “reality effect” on which the veracity of historical discourse depends.¹²⁴ With Muybridge, however, these functions of photography are exploded.¹²⁵ *The Horse in*

123. Siegfried Kracauer, *History: The Last Things before the Last* (New York: Oxford University Press, 1969), pp. 49, 57: “It seems of great interest to me that, in the dimension of the representative arts, Daguerre’s invention raised issues and demands similar to those which played so large a role in contemporary historiography. . . . There is, then, a fundamental analogy between historiography and the photographic media.”

124. Roland Barthes, “The Discourse of History,” in *The Rustle of Language*, trans. Richard Howard (New York: Hill and Wang, 1986), p. 139: “Our entire civilization has a taste for the reality effect, attested to by the development of specific genres such as the realistic novel, the private diary, documentary literature, the news item, the historical museum, the exhibition of ancient objects, and, above all, the massive development of photography, whose sole pertinent feature (in relation to drawing) is precisely to signify that the event represented has *really* taken place.”

125. Barthes relegated Muybridge to his category of photographers who merely “surprise” with their technical prowess, a more recent member of which was Harold Edgerton, who photographed the

Motion is certainly the evidentiary residue of an event in the past, but it is outside of a syntactical and semantic organization that supported historical narrative. The machinic objectivity in play here does not stake out a subjective position from which a “this happened” or a sense of “having been there” could be *authenticated*. It is an early instance of a combinatorial logic in which the individual images, although ostensibly part of a linear sequence and syntax, have a newly autonomous, floating identity. Their immobilization and groundlessness is also the condition for their detachment from any binding continuities or trajectories, in a “decoding” of perceptual experience. Muybridge’s work obviously opened up possibilities for the rationalization and quantification of movement and time, for the mechanization of the body, but, equally importantly, it posed plural scatterings of attention and the possibility of unforeseen perceptual syntheses outside of any disciplinary imperatives. On one hand, the ungroundedness and mutable temporality of these images would be integral to the modern production of a pervasive historical amnesia. On the other hand, Muybridge’s segments would at least suggest the possibility of novel social/historical intuitions, “flashing up” amid their disruptions of presumed continuities or their shattering of the self-sufficiency of an autonomous image.

One of the larger problems that traverses these disparate artifacts from around 1879 is the activation of two incompatible models of individual behavior. Both the Kaiserpanorama and Muybridge’s work are among the multitude of ways in which the selectivity and rhythm of attentive response could be determined through externally controlled variables. Crucial here is how this automation of perceptual experience produced new experiences of dissociation, such as the industrialized sequence of disconnected images in the Kaiserpanorama or the repetitive but disjunct series in Muybridge’s early work. But just at the historical moment when attentive perception within technological culture assumed increasingly automatic forms, modes of human behavior deemed “automatic” were being identified as pathological and socially dangerous: constellations of symptoms involving repetitive actions and dissociated perceptions that seemed severed from the synthetic operations of a unified personality.¹²⁶ In 1878 Alfred Maury, for example, charted a range of conditions including sleep, dreaming, somnambulism, trance,

explosion of a drop of milk to the millionth of a second. “Little need,” Barthes writes, “to admit that this kind of photography neither touches nor even interests me.” *Camera Lucida: Reflections on Photography*, trans. Richard Howard (New York: Hill and Wang, 1981), pp. 33, 99.

126. See, for example, how various forms of socially unassimilable behavior (vagabondage, prostitution, begging) were grouped under the ambivalent diagnosis of “l’automatisme ambulatoire” in the 1880s, in Jean-Claude Beaune, *Le vagabonde et la machine: Essai sur l’automatisme ambulatoire, medecine, technique et societe 1889–1910* (Seysssel: Champ Vollon, 1983).

and hypnogogic states and found “automatic movement” and “mechanical repetition” common to them all.¹²⁷ Conscious or voluntary choice, he insisted, was not possible within these modes of functioning. In the more rigorous work of John Hughlings Jackson a few years later, automatic behavior disclosed a reverse process of evolution, “a process of undevelopment . . . a taking to pieces,” in which there was a loss of the highest activities of “the organ of mind” which for Jackson included “memory, emotion, reason and volition.”¹²⁸

Despite their blatant dissimilarities, the sequences of Muybridge and Klinger are inversely related in terms of their temporal unfoldings of attentiveness: the former as an inflexible, metrical redundancy of position and the latter as a self-transforming process of psychic destabilization. But early in the twentieth century these two poles (the technological and the oneiric) would become overlapping elements within a generalized organization of spectacle, in which a systematic understanding of perceptual synthesis is a prerequisite for the technological production of *managed* and consumable forms of dissociation. One can single out the staging of Wagner’s late works at Bayreuth around the late 1870s for the beginnings of a rationalized production of dreamlike states in audiences that would reach another plateau of fulfillment with the sound film fifty years later.

Even before the actual invention of cinema in the 1890s, though, it is clear that the conditions of human perception were being reassembled into new components. Vision, in a wide range of locations, is refigured as dynamic, temporal, and composite—the demise of the punctual or anchored classical observer begins in the early nineteenth century, increasingly displaced by the unstable attentive subject, whose varied contours I have tried to sketch out here. It is a subject competent to be both a consumer of and an agent in the synthesis of a proliferating diversity of “reality effects,” and a subject who will become the object of all the proliferating demands and enticements of technological culture in the twentieth century. But if the standardization and regulation of attention constitute a path into the digital and cybernetic imperatives of our own present, the dynamic disorder inherent in attentiveness, which Manet’s work begins to disclose, embodies another path of invention, dissolution, and creative syntheses that exceeds the possibility of rationalization and control.

127. See L.-F. Alfred Maury, *Le sommeil et les rêves* (Paris: Didier, 1878).

128. Jackson, *Selected Writings of John Hughlings Jackson*, vol. 2, p. 117.

THREE
1888: Illuminations of
Disenchantment

No one is simply a painter anymore; they are also all archaeologists, psychologists, theatrical producers of this or that recollection or theory.

—Friedrich Nietzsche,
The Will to Power

A “mystery” cannot be posited in the empty region of spirit, where only words foreign to life subsist. It cannot result from a confusion between obscurity and the abstract void. The obscurity of a “mystery” comes from images that a kind of lucid dream borrows from the realm of the crowd, sometimes bringing to light what the guilty conscience has pushed back into the shadows, sometimes highlighting figures that are routinely ignored.

—Georges Bataille, “The Obelisk”

As Manet’s work in the late 1870s moved unpredictably between a stunning unbinding of vision and attempts at a restoration or simulation of cohesion, this shifting engagement facilitated his discrediting of pictorial practices bound up in an older perceptual regime. In a work by Georges Seurat nearly a decade later, it is less a question of undermining traditional representational codes than of the

calculated construction of new semantic and cognitive models. In *Parade de cirque* (finished and first exhibited in 1888) these new models are intertwined with the accelerating reorganization of perceptual experience in the late nineteenth century and with an emerging social environment structured around the attentive capacities of both individual and collective subjects.¹ He arrived at a decisive understanding of the synthetic and disintegrative processes within attention, and his art is inseparable from an attempt to control and rationalize these potentially disorganizing features of perception. But this project of mastery falters and breaks down, and amid its failure *Parade de cirque* both reveals and represses the historical predicament of the individual subject as a modernized observer.

In this painting, the antinomic character of Seurat's thought is pushed to its most creative limit, in which the apparent rigidity (and banality) of his dualistic conceptual schemas produces an object outside their logical control. Charged with antagonistic forces, *Parade de cirque* implacably negates the possibility of aesthetic illusion, of an attentive closure, even as it fervently attempts to generate its own internal formula for an inimitable perceptual presence and unity. No matter how many times one approaches *Parade de cirque* in the Metropolitan Museum, one has an experience of this disjunction: seen from across the gallery the work appears a muted, almost antichromatic haze, like a dull rectangle of slate hanging amid the vibrant Van Goghs and Cézannes, while on closer examination its surface becomes an iridescent field of soft pinks, greens, and blues. The work operates in a ceaseless play of disclosure and concealment, between an ideal of an atemporal fixation of attention and an irrevocable dispersal of perception. The simulation of a timeless stillness barely disguises the historical forces of flux and exchange that are both external to the work and yet fully immanent within it.² Perhaps in no other painting of this period is the experience of modern disenchantment played out as hauntingly. This rendering of a spectral urban nightworld corresponds to what Fredric Jameson has identified as a "magical narrative" in nineteenth-century literature.³ That is, Seurat's work is simultaneously an index of the inexorable pen-

1. I am following Jean-Claude Lebensztein's insistence that everything we know about Seurat's own decisions and actions concerning titling of this work (and several others) for specific exhibitions and catalogs indicates that he never used the definite article; thus Seurat's titles were *Parade de cirque*, *Chabut*, and *Cirque*. For Lebensztein, these choices are part of a larger preoccupation in Seurat's late work with nonspecific temporalities, with an undifferentiated time that is "neither universal, nor particular." See Lebensztein, *Chabut* (Paris: Hazan, 1989), pp. 25–31.

2. Some related themes are developed in terms of Seurat's drawings in Bernd Growe, "The Pathos of Anonymity: Seurat and the Art of Drawing," in Erich Franz and Bernd Growe, *Seurat Drawings*, trans. John Gabriel (Boston: Little, Brown, 1984), pp. 13–50.

3. Fredric Jameson, *The Political Unconscious: Narrative as a Socially Symbolic Act* (Ithaca: Cornell University Press, 1981), pp. 103–150.



Georges Seurat, *Parade de cirque*, 1888.

etration of an aesthetic sphere by rationalizing procedures and an attempt to evade those imperatives through the effects of a magical or epiphanic disclosure. *Parade de cirque* is a powerful instance of Jameson's notion of a "nascent modernism" that "circumscribes the place of the fantastic as a determinate, marked absence at the heart of the secular world . . . an object world forever suspended on the brink of meaning, forever disposed to receive the revelation of evil or grace that never comes."⁴

Parade de cirque, as I will suggest, hovers enigmatically between the evocation, the promise of a chromatic immediacy and the relentless unmasking of the absence and vacancy of appearance within a reified, quantifiable world. Yet both of these possibilities of the work are made available only through Seurat's understanding of the unstable physiological conditions of human vision. In Seurat's

4. Jameson, *The Political Unconscious*, pp. 134–135.

work (and in emerging forms of spectacle) there is no contradiction between the ideal of a spectator absorbed in the luminous presence of the work and the model of an individual subject whose affective responses could be determined by a calculated organization of external stimuli. For, in addition to the methodical production of new chromatic effects, one of the most noted features of Seurat's late paintings is an abiding preoccupation with the rationalization of emotional response, which developed out of his familiarity with a range of nineteenth-century studies (both scientific and aesthetic) of the subjective effects of specific formal elements and relations. *Parade de cirque*, in its alignment with models of technological mastery, announces a collective estrangement from a dream of instinctual wholeness, even as Seurat's obsessive commitment to his "method" was an extravagant quest for a harmonious sensory utopia that subsisted, not just outside of an administered and dissonant world, but beyond the temporality and debacle of history itself. The painting's importance, then, in relation to the historical field I am examining, is this: on one hand it posits a chromatic attentiveness so self-sufficient and subjectively determined as to constitute a provisional realm of freedom for an individual observer; on the other, the painting's aspiration to a managerial control of response coincides with a proliferation of discourses on the attentive subject as a psychic automaton, acting in response to external suggestions in a state of restricted awareness. But *Parade de cirque* finally occupies a psychic, social, and imaginary position that coincides neither with dreams of subjective freedom nor effects of power. It is a shifting plurality of moments, centers, points of view from which the illusions of both aesthetic autonomy and domination are revealed.



Perhaps as much as any nineteenth-century artist's, Seurat's work is inseparable from the consequences of the emergence of models of subjective vision. To amplify this, let me first turn not to a painting but to something Seurat wrote—an excerpt from one of the few documents he produced about his own art practice. In a well-known letter to a friend in 1890, Seurat sought to express, with an oracular brevity, the principles behind what he called his "Aesthetic" and his "Technique." In the paragraph titled "Technique" the first line reads: "Given the phenomena of the duration of a light impression on the retina, synthesis is the unavoidable result."⁵ Concentrated in this austere sentence are a set of terms that

5. The original French is: "Etant admis les phénomènes de la durée de l'impression lumineuse sur la rétine, la synthèse s'impose comme résultante." Georges Seurat, letter to Maurice Beaubourg, August 28, 1890, in Norma Broude, ed., *Seurat in Perspective* (Englewood Cliffs, N.J.: Prentice-Hall, 1978), pp.

provide a guide not only for looking at *Parade de cirque* but for understanding some of the conditions that produced it. First, there is the insistence that vision is durational. For Seurat the apprehension of an image occurs over time and not as part of a punctual or fixed set of relations. He affirms that perception is a *process* consisting of distinct physical events, and his acknowledgment of this “duration” implicitly disavows the stable identity of either the image or the observer. Seurat’s use of the plural “phenomenes” suggests an indefinite number of visual temporalities. Second, there is the privileging of the retina. Here it is a metonym for the seeing body in all of its physiological density and an indication of the ambiguous position of that body within new conceptions of visuality. It invokes the body not as a unified receiver of orderly representations but as a composite apparatus on which external stimuli are able provisionally to produce luminous and chromatic effects. Helmholtz’s illustration of a cross section of the layers of the retina is an exemplary document of a new regime of visuality. Unlike an eighteenth-century diagram of the eye in which light rays enter as if through a transparent lens to transmit an image, Helmholtz’s drawing makes clear that the passage of light into the eye is anything but unmediated. When light enters this opaque “apparatus,” it is no longer as part of a geometrical optics, as rectilinear rays traveling from point to point, but as a form of luminous energy that strikes a dense mosaic of receptors, setting off a complex of processes in this compound organ that culminate in visual perceptions.⁶ Seurat’s statement about the “duration of a light impression on the retina” coincides with this physiological regime of visuality, even though *Parade de cirque*, as I will show presently, exhibits a thorough understanding and calculated subversion of a Renaissance-based pictorial order.

So far, it might be said, Seurat is simply making a concise summation of the conditions of vision that had been set in place in the early nineteenth century beginning with the physiological optics of Thomas Young and Goethe, then developed by Johannes Muller, Helmholtz, and others. But Seurat’s statement goes well beyond those earlier assumptions, particularly in its introduction of the notion of “synthesis.” Of course, in one sense, synthesis refers to Seurat’s celebrated use of “optical mixture,” but this problem cannot be separated from a larger intellectual uncertainty about the nature of cognitive and perceptual unity. A central dilemma

17–19. See also the translation and discussion in Robert L. Herbert, *Georges Seurat, 1859–1891* (New York: Abrams, 1994), pp. 381–382.

6. Helmholtz also emphasizes that the retina (originally meaning cobweb or net, or in German, *die Netzhaut*) was fully part of the nervous system, implying what would be generally accepted by later researchers, that the retina is effectively a part of the brain.

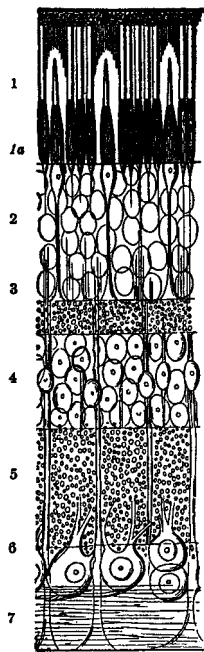

Optical opacity. Cross section of the human retina, from Helmholtz's *Physiological Optics*.

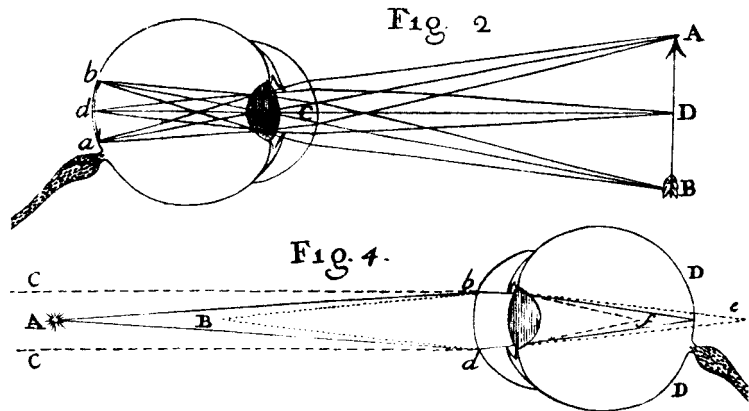

Optical transparency. Eighteenth-century diagrams of light rays and human eye.

in Seurat's work, which will become especially acute in *Parade de cirque*, is his oscillation between the idea of a synthesis that is externally controlled and imposed on a subject (i.e., a rationalization of aesthetic response) and syntheses that are the free subjective invention of an active autonomous subject. A medley of contemporary artists and writers, long since vaguely classed as "symbolists," proposed notions of "synthesis" to designate forms of aesthetic unity that stood over and above fragmented or merely aggregate kinds of quotidian experience.⁷ If Seurat is to be linked, even tangentially, with such positions, it would be in terms of a cultural environment preoccupied with the causes, mechanisms, limits, and weaknesses of psychic and perceptual synthesis, in the absence of a priori solutions. In any case, as his compact statement makes clear, his work is inescapably aligned with the conditions of possibility which I have outlined for the prominence of attention as a problem in the late nineteenth century: (1) an embodied observer, (2) an understanding of perception as fundamentally *durational*, and (3) an active

7. The literature on this subject is enormous. For a brief overview of some of the uses of this term in the late 1880s, see H. R. Rookmaaker, *Gauguin and 19th Century Art Theory* (Amsterdam: Swets and Zeitlinger, 1972), pp. 176–187. For some of the social and political resonances of the term, see John G. Hutton, *Neo-Impressionism and the Search for Solid Ground: Art, Science and Anarchism in Fin-de-Siècle France* (Baton Rouge: Louisiana State University Press, 1994), pp. 17–45.

processing of an aggregate of information. And as we will see, in Seurat's work synthesis is hardly an "unavoidable" result.

In this sense, much of the importance of Seurat's neoimpressionism turns on the question of perceptual organization. With the collapse of the camera obscura model of vision and the emergence of physiological optics, it became increasingly clear that perception was not a matter of a relatively passive *reception* of an image of an exterior world, but that the makeup and capacities of an observer contributed to the *making* of perception. But this approach left crucial issues unsettled. Was perceptual organization something that could be explained mechanistically and could be quantified and predicted in terms of a stimulus-response circuit? Or was it a more dynamic interaction between the attentiveness of an active, choice-making individual and a constantly changing lived milieu? In these terms Seurat's practice in the late 1880s is inseparable from debates about the relatively holistic or atomistic nature of sensory perception. In a broader sense, it is one of the important cultural products of that epistemological crisis whose effects began to be seen clearly by the early 1880s as increasingly inadequate positivist, psychophysical, and associationist models of cognition and perception were supplanted by a wide range of new formulations. Thus my consideration of Seurat's art and the problem of attention inevitably overlaps with the much larger historical problem, beginning in the late 1880s and early 1890s, of the construction of various nonreferential models of perception and the detailing of new interpretive and pragmatic functions of an observing subject.⁸

In 1890 the Austrian psychologist Christian von Ehrenfels published his influential essay "On Gestalt Qualities," opening up a debate about the nature of *form* that is intertwined with a modern crisis of perception.⁹ Ehrenfels, an

8. To better situate Seurat historically, it is worthwhile to consider that the two or three years on either side of his birth in 1859 encompass the births of Henri Bergson, Edmund Husserl, Sigmund Freud, Pierre Janet, Emile Durkheim, Alfred North Whitehead, Ferdinand de Saussure, Alfred Binet, John Dewey, Alois Riegl, Georges Melies, Emile Meyerson, Claude Debussy, Georg Simmel, Gustav Mahler, Max Planck, the neuroscientist Charles S. Sherrington, and the early voice of Gestalt psychology Christian von Ehrenfels. This constellation of names is not inherently significant, and certainly not in the service of some "generational" model of historiography, but it suggests Seurat's position on a surface of events larger than what art history as a discipline can encompass. The work of these figures and others, who all came of age in the late 1880s and early 1890s and most of whom lived much longer than Seurat, was part of an ongoing modernization of knowledge and techniques of perception, cognition, language, and art. Positioned in this way, Seurat's paintings are figurations of new thinking about perception that is identifiable in many different locations during these years. *Parade de cirque*, in addition to whatever else it might be, is an accumulation of propositions about the status of vision and mind, the nature and value of sensation, and the representation of social facts.

9. Christian von Ehrenfels, "Über Gestaltqualitäten," *Vierteljahrsschrift für wissenschaftliche Philosophie* 14 (1890), pp. 249–292. This journal was then edited by the Austrian positivist Richard Avenarius. For English translation see "On Gestalt Qualities," in Barry Smith, ed., *Foundations of Gestalt Theory*

important precursor to much of twentieth-century Gestalt theory, asserted that certain forms have qualities that are unrelated to the qualities of their individual sensory components. Here the problem of form takes on some of its specifically modern features, and he attempts, as would so many who followed, to formulate “laws” that would give to perception a semblance of some of the same unconditional guarantees that vision had had within a classical regime of visibility. Ehrenfels’s essay was a crystallization of various contemporary notions that a form exists independently of its parts and that perception had an intrinsic unifying tendency to resist atomization and fragmentation. Equipped with a musical background (he had been a student of the composer Anton Bruckner and was also influenced by Carl Stumpf’s work on the psychology of tone), he drew some of his primary examples from music.¹⁰ He pointed to how a melody retains its identity when it is transposed to a different key, that is, how a certain formal identity endures even though the separate notes are no longer the same. In his words, “Characteristic of Gestalt qualities is that they constitute a presentational content dependent upon yet distinguishable from their foundation.”¹¹ It was a question of emphasizing the significance of mutual *relations* among sensations rather than an analysis in terms of individual elements. Ehrenfels was interested in both temporal and spatial formalities and assessed the ways in which shape and other plastic qualities did not depend on the elements out of which they were composed, for example, that the same silhouette can be recognized instantly, regardless of its size or color or whether it is in the form of drawing, painting, relief carving, or photograph.

Ehrenfels’s text is important here not because it illustrates aspects of Seurat’s practice, but for how they both highlight the new importance of questions of perceptual and cognitive synthesis central to many developments in the visual culture of the West in the late nineteenth century, including cinema. For *Parade de cirque* raises the issue of how, even from close distances, the representational features of the painting (the figures, the architectural setting) have a perceptual coherence that is unrelated to the individual touches of color out of which they are consti-

(Munich: Philosophia Verlag, 1982). See the assessment of Ehrenfels’s originality in Wolfgang Kohler, *The Task of Gestalt Psychology* (Princeton: Princeton University Press, 1969), pp. 45–48.

10. Anne Harrington discusses Ehrenfels’s enthusiasm for Wagner, his friendship with Houston Stewart Chamberlain (who fashioned a racial Gestalt theory), and his interest in eugenics, in her *Reenchanted Science: Holism in German Culture from Wilhelm II to Hitler* (Princeton: Princeton University Press, 1996), pp. 108–111. See also the account of Ehrenfels’s influence in Mitchell G. Ash, *Gestalt Psychology in German Culture, 1890–1967: Holism and the Quest for Objectivity* (Cambridge: Cambridge University Press, 1995), pp. 88–90.

11. Ehrenfels, “On Gestalt Qualities,” p. 96.

tuted.¹² For example, the dots of orange, blue, and yellow-orange that make up the three musicians at the left of the painting have nothing in common with our experience of those figures suffused in a shimmering hazy violet. The violet color would be what Ehrenfels called a “Gestalt quality,” and he in fact proposed that “wherever there is the simultaneous (though not spatially coincident) givenness of different colors and light intensities, a sufficient foundation for Gestalt qualities would seem to be at hand. . . . Certainly, we receive from the simultaneous juxtaposition of different colors an impression whose affinity to harmony is indeed registered linguistically in talk of ‘color harmony.’ . . . We believe that we can regard color harmonies and disharmonies as Gestalt qualities, even though they may change totally with the transposition of their foundations.”¹³

Unlike the twentieth-century Gestalt theories of Kohler, Wertheimer, and others, Ehrenfels made clear that Gestalt qualities were not necessarily a privileged order of sense data and that they alternated temporally with a perception of more elementary sensations. Later Gestalt theory would insist on the essential primacy and even ethical value of the *whole*, and assert that individual units or sensations were subsumed by the Gestalt. In a sense Ehrenfels (and the related work of Ernst Mach) remained closer to something essential in the perceptual logic of high capitalism. They understood that atomistic association and Gestalt holism are not irreconcilably opposed but are two different and coexisting modes of attention through which perceptual experience can be figured, codified, or understood and that each has its usefulness or value in given situations.¹⁴ Seurat’s work, too, operates in an indeterminate oscillation between these two poles.

There is a broad range of work on perception in the late nineteenth and early twentieth century that in various ways opposed the atomizing accounts of perception inherent in behaviorism, biologism, reflexology, and other supposedly “reductive” approaches, and attempted to establish an image of the observer as an autonomous, intentional subject for whom perceptual organization is the product of a lived, situational, and dynamic activity. It was a loosely identifiable type of

12. Some of these issues were addressed from a formalist standpoint in Niels Luning Prak, “Seurat’s Surface Pattern and Subject Matter,” *Art Bulletin* 53 (1971), pp. 367–378.

13. Ehrenfels, “On Gestalt Qualities,” pp. 95–96.

14. This acceptance of the value of “complementary concepts” was dramatized two decades later when the inseparability of wave and particle physics made it clear that “atomism” could neither be rejected nor exclusively privileged. “The example of physics therefore will doubtless furnish an argument which will have considerable weight when our judgment of psychological atomism comes in for revision.” Robert Blanche, “The Psychology of Duration and the Physics of Fields,” in P. A. Y. Gunter, ed., *Bergson and the Evolution of Physics* (Knoxville: University of Tennessee Press, 1969), p. 113.

observer that took shape, for example, in empathy theory, in German form psychology, and notably in Bergson's *Time and Free Will* of 1889 and James's *Principles of Psychology* of 1890. It was an observer constructed in many places to counter the claims of an antihumanist stimulus-response psychology or behaviorism—an observer who perceives organized structures, not accumulations of disjunct sensations, an observer marked by innate form-giving and form-apprehending capacities. The approach was to be more fully articulated by the 1920s in Gestalt theory and phenomenology, in an effort to endow human perception with an inherent meaningfulness, coherence, and even orderliness amid its perpetual mutation, instrumentalization, and decomposition within twentieth-century spectacular culture. This later work generally insisted that it was not the attentive subject who identified form, or distinguished form from a larger background, but rather the reverse, that “good” form had the capacity to produce attentiveness in a subject.¹⁵

Seurat's distance from this model of an observer is mirrored by his ambivalent position within traditional art historical writing. Part of his status as modern master is built on the belief that his work, even if a central part of some modernist rupture, is in dialogue with the great masters of the past (Phidias, Piero, Leonardo, Holbein) and thus is an affirmation of “timeless” formal values and of an aesthetic continuity that effectively domesticates some of the anti-aesthetic features of his work. But the reverence for Seurat's refurbished “classicism” has usually coexisted with an uneasiness about what is seen as his overreliance on “systems.”¹⁶ In its vulgar form, this was expressed as a mistrust of a mechanical application of scientific theories to art making and of a technique seen as a deplorable de-skilling of aesthetic mastery.¹⁷ But more pervasively there has been a tacit

15. In contrast to Ehrenfels's emphasis on the overlapping and interpenetration of the senses, later Gestalt theory transposed cognitive and epistemological problems into primarily *visual* terms. Judith Schlanger argues that Gestalt theory was fundamentally antidiscursive in its positing of an equivalence between seeing and understanding (e.g., in Wertheimer) and in its marginalization of the verbal, in her *L'invention intellectuelle* (Paris: Fayard, 1983), pp. 69–80.

16. Typical is the following assessment: “With him the balance between sensibility and doctrine was a delicate one. If the doctrine were to cease to be amenable to constant correction by the sensibility it might become the predominant partner; demonstration would replace inspiration and theory passion. There was certainly a tendency for this to happen towards the end of Seurat's short life.” Roger Fry, *Transformations* (London: Chatto and Windus, 1927), p. 191. But this type of critical response began during Seurat's lifetime, even among writers who had initially been unreservedly supportive. See the account of Felix Feneon's eventual estrangement from what he perceived as Seurat's overly schematic technique, in Joan Ungersma Halperin, *Felix Feneon: Aesthete and Anarchist in Fin-de-Siecle Paris* (New Haven: Yale University Press, 1988), pp. 128–131.

17. See, for example, the recent pointless insistence that Seurat's aesthetic ambitions were often “smothered by the textbooks of the physicists,” in Alain Madeleine-Pedrillat, *Seurat*, trans. Jean-Marie

sense that Seurat's neoimpressionism, as technique and idea, is somehow finally not successful in itself and that part of its art historical significance is its merely transitional and preparatory role in a larger flowering of modernism from which Seurat is excluded. To read between the lines of many standard accounts, neoimpressionism is important because of its didactic significance in the visual apprenticeship of some great early twentieth-century modernists, above all Matisse, Kandinsky, and Mondrian, disclosing to them the enormous and as yet untapped potential of pure autonomous color. The implication is that the concrete practice of divisionism is not an aesthetic achievement of the same magnitude as the mature visions of the artists for whom it was only a passing and relatively early phase, and that the methodical, systemic texture of Seurat's work does not disclose the optical fullness and presence of, say, a post-1905 Matisse. But such treatments of early twentieth-century art prefer to repress what Marcel Duchamp and others realized about Seurat's work: that it was a *repudiation* of the modernist myth of the "liberation" of pure color.¹⁸ For Seurat, regardless of what may have been his ultimate aesthetic aspirations, the experience of color was never given or unmediated. As it was for Helmholtz and later for Charles Sanders Peirce, color was instead always a construction, a complicated inference. Peirce's critique of direct perception and immediate awareness in fact provides some crucial epistemological concepts for thinking through Seurat's practice: "No one can know what an impression is like in itself. . . . Color is sometimes given as an example of an impression. It is a bad one; because the simplest color is almost as complicated as a piece of music. Color depends upon the *relations* between different parts of the impression; and, therefore, the difference between colors are the differences between color harmonies; and to see this difference we must have the elementary impressions whose relation makes the harmony. So that color is not an impression, but an inference."¹⁹ At the same time Seurat, in his decomposition of local color, undermined the

Clarke (Geneva: Skira, 1990), p. 177. Seurat's method is linked with the erosion and leveling of aesthetic values and with increasing democratization and technological modernization in Clive Bell, *An Account of French Painting* (New York: Harcourt Brace, 1931), p. 205: "Seurat wished to devise a completely impersonal method of expression, appropriate to an age of equality to which he sincerely and generously looked forward, *a method which could be learnt as one learns to use the typewriter*. He set himself therefore to provide for the citizens of an approaching social democracy a series of scientifically coloured and graded discs, and a small collection of geometrical forms. In these the maladroit but inspired artist of the future would find the synthetic equivalents of the forms and colours of nature." (Emphasis added.)

18. See the superb discussion of Duchamp's relation to Seurat's technical practices in Thierry de Duve, *Pictorial Nominalism: On Marcel Duchamp's Passage from Painting to the Readymade*, trans. Dana Polan (Minneapolis: University of Minnesota Press, 1991), pp. 170–173.

19. Charles Sanders Peirce, *Writings of Charles S. Peirce*, vol. 1, ed. Max H. Fisch (Bloomington: Indiana University Press, 1982), pp. 515–516.

identity of even the last kind of “natural” sign available to a visual artist: the one sign that might still have seemed to operate within a logic of resemblance instead had its “unnatural” or constructed character laid bare.²⁰

For years modernist criticism emphasized the structural equilibrium of Seurat’s “classicism,” but far more important is the disturbance of a stable optical attentiveness to the work. The oscillation inherent in one’s experience of Seurat’s divisionist technique prevents a single perceptual organization of the painting, and instead it subsists uncertainly between its elemental composition and a never fully completed fusion. The rhythm of shifting back and forth between these poles corresponds to a new understanding of attention as *both* binding and disintegrative, as incapable of fixation. At issue is not simply the obvious fact that the work (like other paintings) is always *both* a representational image and a mosaic of colored spots. Rather the ubiquity and homogeneous distribution of Seurat’s mosaic surface poses perception as something that can be prior to or fully outside of a visual organization of figure and ground. Gestalt theory, in many of its guises, was to be an attentive discipline in which there is an imperative to have attention settle or arrest on a normative organization of a sensory field.²¹ It was a dream of the reciprocal affirmation of the unity of the individual subject and the unified objects of perception. Seurat’s practice affirmed neither, and in *Parade de cirque* the appearance of structural clarity is undermined by far more powerful disruptive processes.

The refusal of a final fusion in Seurat’s neoimpressionism, or rather the insistence that fusion is a provisional event, dependent on the physiological makeup and physical mobility of the spectator, poses both attention and perceptual organization as fluid and reversible.²² One of the most obvious ways we experience the work is through our own physical movement—back and forth, from a position

20. As several studies have demonstrated, *Parade de cirque* is one of the works after 1886 that signal a new level of abstraction in Seurat’s practice, specifically in terms of a more thorough abandonment of local color. He has almost completely ceased to use apparent color to depict objects or forms (the color that things would seem to be if we saw them in white light). The colors that are literally on the canvas have no referential relation to the forms they constitute and exist on the surface as autonomous units of abstract color, whether of orange, blue, green, or purple.

21. For a provocative discussion of the idea of an imperative to perceptual competence, see Alphonso Lingis, “Imperatives,” in M. C. Dillon, ed., *Merleau-Ponty Vivant* (Albany: State University of New York Press, 1991), pp. 91–116.

22. For an important countermodel of perception, see the chapter on “Two Kinds of Attention” in Anton Ehrenzweig, *The Hidden Order of Art: A Study in the Psychology of Artistic Imagination* (Berkeley: University of California Press, 1967), pp. 21–31. The author identifies the functioning of a “dedifferentiated” vision which operates outside of “the conscious gestalt compulsion” to “bisect the visual field into significant ‘figure’ and insignificant ‘ground.’”

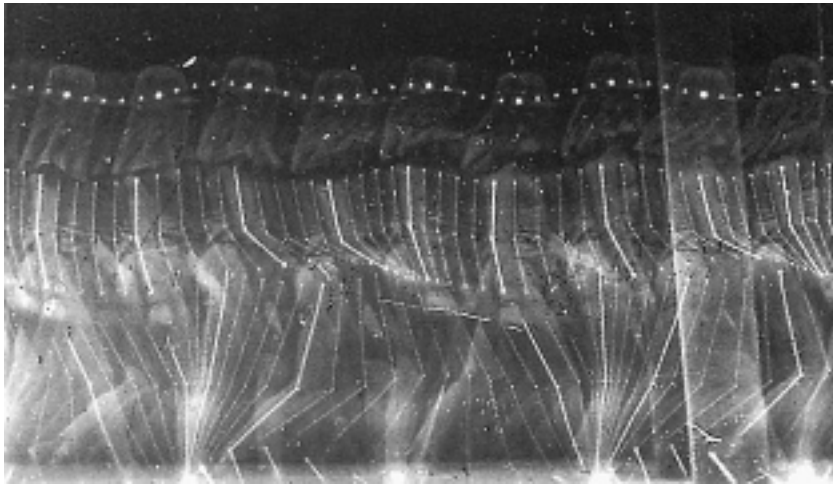

Jules-Étienne Marey, chronophotograph of man walking, late 1880s.

close enough that the individual touches of color are distinguishable and the constructed nature of the surface is evident, to a more distant point at which the surface coalesces into a shimmering image of a recognizable world. One might understandably claim that this is how we also experience older art, say a late Rembrandt or a Velazquez, but Seurat shows a self-conscious and systematic awareness of the part played by the spectator in the making of the work. It is very likely that he thought carefully about the different effects of the surface from specific distances and thus made his art for a mobile spectator who would occupy multiple viewpoints.²³ Seurat, like others around this time, was testing the limits and possibilities of an observer attentive to a heterogeneity and simultaneity of sensory data. Specifically, he examined how an irreducible plurality of luminous information could be organized and perceived coherently, but also how it could be rearranged and made exchangeable. It is in this sense that Seurat's exploration of new perceptual modalities can be compared with the physiologically based work of Etienne-Jules Marey. Marey's images, especially in the late 1880s with their overlapping transparencies, are also a repudiation of perceptual fusion, in that they constitute a visual field in which the viewer shifts back and forth between different levels of

23. David Sutter, the Swiss aesthetician whose work Seurat studied, wrote: "The distance of the spectator to the painting is an *arbitrary distance*, for it varies according to the nature of the subject one is treating." Sutter, *Nouvelle theorie simpliffee de la perspective* (Paris: Jules Tardieu, 1859), p. 24; emphasis in original.

organization—between a holistic perception of a single temporal vector and an aggregate apprehension of isolated positions.

Ernst Mach's highly provisional notion of sensation may provide a frame for understanding its ambiguous position in Seurat's work as well. Mach used the word "sensation" without attributing to it any ultimate truth value, just as he rejected the idea of the real existence of atoms. For Mach, it was most *useful* to assert that the world consisted of "colors, sounds, temperatures, pressures, spaces, times," which he preferred to call "elements." These elements "are connected with one another in manifold ways: and with them are associated moods of mind, feelings and volitions. Out of this fabric, that which is relatively more fixed and permanent stands prominently forth, engraves itself in the memory, and expresses itself in language. Relatively greater permanency is exhibited, first, by certain *complexes* of colors, sounds, pressures and so forth, connected in time and space, which therefore receive special names and are designated *bodies*. Absolutely permanent such complexes are not."²⁴ What Mach and Seurat both renounce is any attempt to give an objective picture of the world; instead they each seek provisional and practical ways of representing various complexes of elements that have no essential substance or permanence. That which appears as a distinct body or object is effectively "an economy of mental representation." Crucial for both of them is the usefulness of multiple points of view and systems of representation: for Seurat, perceptual experience is presented simultaneously in terms of a schematic realism, a decomposition of the properties of luminous phenomena, and an analysis of the chromatic sensibility of the human retina. None of these levels has any priority. Mach too made it clear that he neither rejected nor affirmed naive realism; rather it was a view of the world that was useful in many situations, though he felt it rarely advanced scientific understanding. Ian Hacking proposes the early 1890s as the time when Western science accepts the notion "that there might be several ways to represent the same facts." He cites the 1894 book by physicist Heinrich Hertz, *Principles of Mechanics*, as emblematic of this turning point: in it Hertz outlines "three images of mechanics, three different ways to represent the then extant knowledge of the motion of bodies."²⁵ For both Mach and Hertz, physics

24. Ernst Mach, *Contributions to the Analysis of the Sensations* (1885), trans. C. M. Williams (La Salle, Ill.: Open Court, 1890), p. 2. Translation modified.

25. Ian Hacking, *Representing and Intervening: Introductory Topics in the Philosophy of Natural Science* (Cambridge: Cambridge University Press, 1983), p. 143. Hacking associates this shift in scientific practice with postimpressionism, which also proposed "new systems of representation" in the 1880s. Henri Poincaré discussed the ephemeral nature of scientific theories and, citing Hertz, insisted that "it may be shown that we can explain everything in an unlimited number of ways." Poincaré, *Science and Hypothesis* (1902), trans. J. Larmor (New York: Dover, 1952), p. 168.

was fundamentally a question of *perception*. But unlike Hertz, Mach ultimately believed (as did Nietzsche, Bergson, Richard Avenarius, Hans Vaihinger, and others) that scientific rationality had to be in the service of life. The value of any scientific account was the extent to which it satisfied human biological needs, the extent to which it was life-enhancing.

The question of whether a representation of the world could in some way be life-enhancing traversed both aesthetic and philosophical thought at this time. Seurat is particularly relevant in terms of his investigation of how visual stimuli could produce various physical and psychological states, including happiness and tranquillity. He clearly explored many theoretical explanations, some long established, of how emotional response could be controlled, but most significant was his interest in relatively contemporary ideas that involved the concepts of “dynamogeny” and “inhibition.”²⁶ We will never know with any certainty or specificity how Seurat engaged these concepts, nor will anything be learned by studying Seurat’s paintings as if they were attempted “applications” of a theory to an artistic practice, even though it is clear that he became interested in these ideas while planning *Parade de cirque*.²⁷ If indeed this body of knowledge was effectively adjacent to Seurat’s practice (and there is very little reason to suspect it was not), it is important to understand the nature of the powerful institutional discourses in which they were formed and operated and how they are linked with the conflicting ambitions of *Parade de cirque*.

Seurat’s practice intersects with a model of the human subject that became increasingly dominant in a number of fields during this period, and had wider cultural effects as well. The notion of “dynamogeny” comes out of some of the most significant experimental physiological work of the nineteenth century, in

26. It has long been known that Seurat was familiar with the work of D. P. G. Humbert de Superville, who had attempted a theory explaining the expressive values of both color and line in his *Essai sur les signes inconditionnels dans l'art* (1827). Humbert’s work was summarized in Charles Blanc, *Grammaire des arts du dessin: architecture, sculpture, peinture* (1867; Paris: H. Laurens, 1880). Of course what separated these earlier accounts from dynamogenic/inhibitory explanations of such effects is that they were not linked to a comprehensive accumulation of knowledge about the body, brain, and nervous system.

27. Robert Herbert has shown that by 1887 Seurat was familiar with Charles Henry’s exposition of these ideas, in his “‘Parade de cirque’ de Seurat et l’esthétique scientifique de Charles Henry,” *Revue de l’art* 50 (1980), pp. 9–22. Herbert has more recently amended some of his conclusions in this article but nonetheless reaffirms that, before beginning *Parade de cirque*, Seurat had assimilated from contemporary physiology the notion “that all emotional responses, including unconscious ones, can be traced to the activity of nerves and muscles that reflect the relative ease or discomfort induced by the stimulus.” See his “Appendix L: Charles Henry,” in Herbert, *Georges Seurat, 1859–1891*, pp. 391–393. There, Herbert also cautions against attempting to find specific formal correlations between Seurat’s work and Henry’s system of movements and directions.

particular work from the 1850s and 1860s, which constructed models of the reflex functioning of the human nervous system and investigated the nature of human response to external stimulation. For a long time it was wrongly assumed by many art historians that these concepts were the invention of Seurat's friend, the librarian and quasi-scientist Charles Henry, but in fact they were part of a large and collective body of psychological and neurological concepts that by the end of the 1880s had become widely familiar and influential.²⁸ Such research was assembling a detailed reconfiguration of a human subject, which would be central to a vast range of modernizing projects in the West well into the twentieth century, and more specifically a new inventory of the capacities and functions of an attentive observer.

The chief figure involved in the early diffusion (and most likely coinage) of the term "dynamogeny" was the French-American physiologist Charles-Edouard Brown-Sequard (1817–1894).²⁹ Much of his research studied the connection between sensation and reflex movements, and he classified various normal and pathological functions of the nervous system in terms of this relation. Like others before him, he noted effects of "inhibition": that certain kinds of irritation or stimulation (whether from sound, light, electricity, or touch) of one nerve center could dampen or diminish action at another distant center, producing a kind of anesthesia. His work was to be an important part of Théodule Ribot's claim that attention was dependent on the body's capacity for the inhibition of certain motor centers.³⁰ In the late 1870s Brown-Sequard concentrated on the opposite properties by which stimulation produced a heightening or augmentation of function, usually

28. One of the first texts to establish some of the sources for Henry's formulations was Jose Arguelles, *Charles Henry and the Formation of a Psycho-physical Aesthetic* (Chicago: University of Chicago Press, 1972). More recently, Michael Zimmermann has produced an extended survey of the intellectual and cultural context of Seurat's work, including accounts of the relevant theories of Brown-Sequard, Fere, Henry, and many others, in his massive *Seurat and the Art Theory of His Time* (Antwerp: Fonds Mercator, 1991). See the valuable chapter on "Physiological Aesthetics" in Martha Ward, *Pissarro, Neo-Impressionism, and the Spaces of the Avant-Garde* (Chicago: University of Chicago Press, 1994), pp. 124–146.

29. His ideas were initially articulated in Charles-Edouard Brown-Sequard, *Physiology and Pathology of the Central Nervous System* (Philadelphia: Lippincott, 1858). For a statement of his neurological model in its mature form, see Charles-Edouard Brown-Sequard, *Recherches experimentales et cliniques sur l'inhibition et la dynamogenie* (Paris: Masson, 1882). See the memorial article on Brown-Sequard in the journal that he founded with Charcot in 1867 and of which he was the sole editor from 1889 until his death, E. Gley, "C.-E. Brown-Sequard," *Archives de physiologie normale et pathologique*, 5th ser., 6 (1894), pp. 759–770. See also J. M. D. Olmsted, *Charles-Edouard Brown-Sequard* (Baltimore: Johns Hopkins University Press, 1945), esp. pp. 159–167. Brown-Sequard's historical significance in nineteenth-century psychophysiology is discussed in Roger Smith, *Inhibition: History and Meaning in the Sciences of Mind and Brain* (Berkeley: University of California Press, 1992), pp. 130–133.

30. Théodule Ribot, *The Psychology of Attention* (1889; Chicago: Open Court, 1896), pp. 40–41.

accompanied by vasocongestion, in some other part of the nervous system, which he called “dynamogenesis.”³¹ By 1885, his model of the human organism had certain thermodynamic features: “I hardly need to say that in both cases [dynamogeny and inhibition] it is a question of a transformation or displacement of forces, since these cannot be destroyed or created.”³² Thus it was part of a larger and pervasive *economic* conception of organic function, also one of the conditions of possibility for later dynamic psychological and neurological theories. Although the word *dynamogeny* had a relatively brief currency of perhaps twenty-five years, it effectively was deployed in the 1880s and early 1890s to mean the same thing as the term “excitation.” Thus the eventual obsolescence of the term (or its origin in the particularities of Brown-Sequard’s understanding of the nervous system) should not obscure the cultural significance of the concepts it ponderously though evocatively designated. *Inhibition*, however, clearly has had a different and far more durable destiny as a signifier. In the work of Hughlings Jackson and others, inhibition was privileged outside of any duality as an integrative force that prevented the dissolution of higher, organized mental functions by “inhibiting” lower and instinctual processes.

In the 1880s and well into the 1890s, other researchers continued to use these terms to describe related phenomena. Rather than discuss Charles Henry’s appropriation and use of these ideas, I will briefly mention a more widely read figure whose work was equally accessible to Seurat.³³ Charles Fere, who had been

31. It has been noted that dynamogeny, as a stimulation of functioning, is related to the concept of “facilitation” as it developed in the 1895 “Project” of Freud and in the work of his former teacher Sigmund Exner. Jean Laplanche and J. B. Pontalis define this term: “Excitation, in passing from one neurone to another, runs into a certain resistance; where its passage results in a permanent reduction in this resistance, there is said to be facilitation; excitation will opt for a facilitated pathway in preference to one where no facilitation has occurred.” Laplanche and Pontalis, *The Language of Psychoanalysis*, trans. Donald Nicholson-Smith (New York: Norton, 1973), p. 157.

32. Charles-Edouard Brown-Sequard, “Dynamogenie,” in *Dictionnaire encyclopédique des sciences médicales*, 1st ser., vol. 30 (Paris: Asselin, 1885), pp. 756–760. For an exposition of these ideas in a popular science magazine, see L. Menard, “L’inhibition,” *Le Cosmos: Revue des Sciences* 71 (June 4, 1887), pp. 255–256. Brown-Sequard’s position in the development of nineteenth-century dynamic psychologies is outlined in Henri F. Ellenberger, *The Discovery of the Unconscious: The History and Evolution of Dynamic Psychiatry* (New York: Harper, 1970), pp. 289–290.

33. Charles Henry, during the same years as Fere, assimilated these ideas, and his work has been discussed at length in many art historical studies of Seurat. Drawing on earlier nineteenth-century studies on art, Henry attempted to account for the physiological effect of colors, movements, rhythms, and directions. He insisted that “every stimulus is dynamogenic or inhibitory,” to a lesser or greater degree. See, for example, his “Le contraste, le rythme, la mesure,” *Revue philosophique* 28 (1889), p. 364. He formulated a complex, often incoherent system, using his proprietary “aesthetic protractor,” in which movements are dynamogenic or inhibitory according to whether they are continuous or discontinuous, or whether they go from left to right or right to left, and upward or downward. See Arguelles’s tendentious yet sometimes useful *Charles Henry and the Formation of a Psycho-physical Aesthetic*. I strongly

personal assistant to and then a colleague of Charcot, conducted experiments on human subjects in which he measured physiological response to various forms of stimulation and attempted to quantify the relative strength or weakness of dynamogenic or inhibitory effects. He and others at the clinics of the Salpêtrière and Bicêtre used a device called a dynamometer which measured the pressure exerted by the hand grip of a test subject as that subject was exposed to (and specifically asked to be attentive to) various kinds of stimuli. It yielded a graphic indication (called a *dynamographe*) of the rise and fall of that muscular pressure in relation to the external variables.³⁴ Of the many kinds of demonstrations cited by Fere, the most relevant here are his optical experiments, in particular those involving color. In describing the physiological effects of luminous impressions, Fere showed that orange and red produced heightened physical response in both “normal” and “hysterical” subjects.³⁵ Blue and violet produced a diminution in measurable physical response, i.e., an inhibitory effect. Perhaps the most significant part of Fere’s research was the conclusion that attention itself could have dynamogenic characteristics: that is, the heightened state of alertness, effort, or tension created condi-

disagree with Arguelles’s picture of Henry as the prophetic voice of a “scientific-mystical aesthetic” of the future. Like many commentators, he ignores Henry’s less lofty interest in the application of psychological and physiological knowledge to forms of social control and the rationalization of labor, and he barely mentions his sad end in the 1920s as he tinkered with the invention of proto-Reichian “bio-resonators.” To fully understand Henry’s dilettantish career, one probably ought to look less at parallels with Pythagoras and Leonardo and more at those with Flaubert’s Bouvard and Pecuchet, that is, to the social identity of Henry as a bourgeois librarian and autodidact at the Sorbonne and to related nineteenth-century fantasies of a universality of knowledge in all its newly reified and consumable forms, about which Flaubert has said the last word. One can also position Henry in relation to Philip Nord’s observation that Third Republic print culture “nursed pedagogical ambitions of a scientific, encyclopedic cast” based on a utopian “imagining of a universal order in which human beings might live in harmony with nature and themselves.” Nord, *The Republican Moment: Struggles for Democracy in Nineteenth-Century France* (Cambridge: Harvard University Press, 1995), p. 191.

34. The origins of the dynamometer go back into the eighteenth century according to Anson Rabinbach, who details the history of various devices used for quantifying the force of human effort, in his *The Human Motor: Energy, Fatigue, and the Origins of Modernity* (New York: Basic Books, 1990), p. 30. Fere’s devices and graphical method were probably derived from the work of E. J. Marey. See the related discussion in Marta Braun, *Picturing Time: The Work of Etienne-Jules Marey* (Chicago: University of Chicago Press, 1992), pp. 321–323. For an account of Fere’s experimental practices at the Salpêtrière in the 1880s, see Dianne F. Sadoff, *Sciences of the Flesh: Representing Body and Subject in Psychoanalysis* (Stanford: Stanford University Press, 1998), pp. 91–100.

35. Henri Bergson dubiously acknowledged the significance of Fere’s work, indicating how it was bound to an impoverished notion of sensation: “Doubtless, a closer examination of what takes place in the whole of the organism when we hear such and such a note or perceive such and such a color has more than one surprise in store for us. Has not Charles Fere shown that every sensation is accompanied by an increase in muscular force which can be measured by the dynamometer?” For Bergson, such demonstrations are ultimately irrelevant since they fail to understand the essential indivisibility and interpenetration of the psychic states related to such sensations. Bergson, *Time and Free Will* (1888), trans. F. L. Pogson (New York: Harper, 1960), p. 41.

tions within the nervous system for heightened reactions to sound and color in particular.

Several points should be emphasized. One is that the model of the attentive subject here is emphatically a nonoptical one. That is, the subject here is not one who primarily sees but rather one who is susceptible to what Fere called “psychomotor induction.”³⁶ In the words of his teacher Charcot, it was a question of “the dynamogenic influence of the visual on the motor center.”³⁷ Color, as certain wavelengths of luminous energy, has effects not on an autonomous optical sensibility of the spectator but on the body as a complex nervous and motor organism. Fere goes so far as to make this extraordinary formulation: “When rays of red light strike our eyes, *our entire body sees red*, as dynamometric reactions prove.”³⁸ The repudiation of a classical optical model in this remarkable sentence is a concise summation of one of the most powerful ways in which vision was reformed in the nineteenth century. Following the graphical method of E. J. Marey’s physiological studies, Fere’s dynamographs are evidence of how what were once figured as visual representations are now the abstract and quantified reactions of the body as a composite set of physical systems.³⁹ Far from discovering any “natural” functions, Fere’s work is part of a larger *instrumental* relocation of vision from a disembodied and punctual system of images to an interplay of forces and motor reactions in which representations play an irrelevant role. The truth of seeing is shifted to a completely nonoptical terrain. The retina is now compounded with a neuromotor system that is triggered externally. Sensation and movement become a single *event*. It is no longer a question of a single discrete sense but of the senses producing exchangeable effects and responses, and of different sensory stimuli being “translated” into the same movements or tensions.

Dynamogeny comes out of knowledge in which the meanings of “sensation” have shifted almost unrecognizably from those of the beginning of the nineteenth

36. Charles Fere, *Sensation et mouvement* (1887; Paris: F. Alcan, 1900), p. 87. Fere’s work is inseparable from a larger project of social “prophylaxie,” and from a Spencerian linking of national prosperity with the scientific amelioration of collective emotional hygiene. See, especially, his *La pathologie des émotions* (Paris: Felix Alcan, 1892), pp. 553–572.

37. J.-M. Charcot, *Clinical Lectures on Diseases of the Nervous System*, ed. Ruth Harris (London: Tavistock, 1991), p. 310.

38. Fere, *Sensation et mouvement*, p. 152; emphasis added.

39. On Marey’s rejection of sensation and direct observation as tools of scientific investigation, see François Dagognet, *Etienne-Jules Marey: A Passion for the Trace*, trans. Robert Galeta (New York: Zone Books, 1992), pp. 15–63. For a historical overview of various modern attempts to “transcribe” bodily movement, from the 1880s to the 1920s, see Pacal Rousseau, “Figures de déplacement: L’écriture du corps en mouvement,” *Exposé 2* (1995), pp. 86–97.

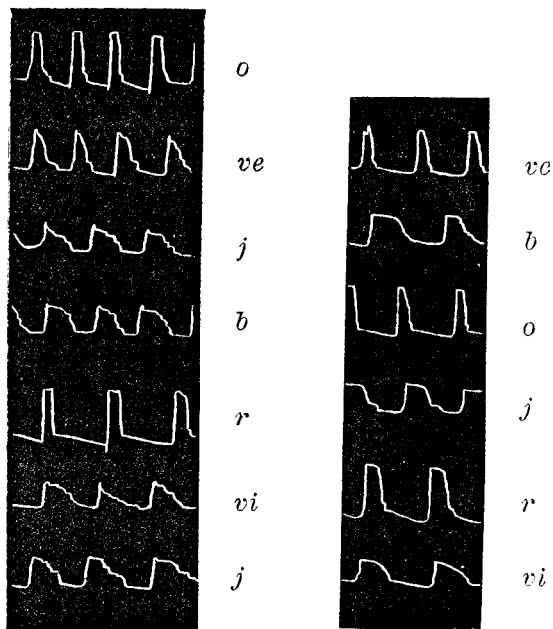

FIG. 19 et 20. — Contractions sous l'influence du rouge *r*, de l'orangé *o*, du jaune *j*, du vert *ve*, du bleu *b*, du violet *vi*. (Les tracés se lisent de droite à gauche.)

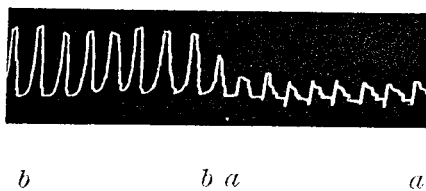

FIG. 18. — *aa*, contractions normales; *bb*, contractions sous l'influence des rayons rouges. (Le tracé se lit de droite à gauche.)

Graphical representations of dynamogenic response to color, from Charles Fere, Sensation et mouvement, 1887.

century and earlier. Sensation has ceased to designate an element of psychical processes through which a mental or visual representation of the world will be assembled.⁴⁰ Rather, it is part of a sequence of events in which the end point is not an inner state, such as knowledge or cognition or perception: instead, sensation is that which culminates in movement, regardless of whether that movement is voluntary or automatic, inner or outer. Beginning in the 1850s, there was a widespread conceptualization (by both scientists and philosophers) of a fundamental relation between sensation and motor behavior.⁴¹ Some of the rationalizing ambitions in Seurat's work are both directly and indirectly informed by these new functional models, which propose that sensory stimuli will produce a *motor* expression in a perceiver. Most importantly it is a question of human response based on the *bypassing* of conscious thought altogether, undermining the long-established image of Seurat's art as intellectual constructions directed to the rational mind of an observer. Whatever may have been its other ambitions, Seurat's method (as it

40. Martin Kemp makes a related distinction in the conclusion to his *The Science of Art: Optical Themes in Western Art from Brunelleschi to Seurat* (New Haven: Yale University Press, 1990), p. 319. He sees the overlapping concerns of Charles Henry and Seurat as marking a shift from visual analysis and the recreation of nature to a preoccupation with "the responses of the senses and the mind which comprised a new kind of psychological reality. This new thrust leads us away from the tradition of optical observation."

41. One can look back to the work of William B. Carpenter, who, by the early 1850s, had coined the term "ideo-motor action" to describe muscular movements that were induced automatically by certain ideas, occurring outside of any volitional control, in his *Principles of Mental Physiology* (1874), 7th ed. (London: Kegan Paul, 1896), p. 279. Ideo-motor actions were "the direct manifestations of Ideational states excited to a certain measure of intensity, or in physiological language, reflex actions of the Cerebrum." See the summary and critical revision of Carpenter's work in Thomas Laycock, "Reflex, Automatic and Unconscious Cerebration: A History and a Criticism," *Journal of Mental Science* 21, no. 96 (January 1876), pp. 477–498. Gustav Fechner's work also had enormous impact in terms of later dynamic or energetic models of the nervous system: "No stimulus functions passively. Some stimuli, such as light and sound, can be conceptualized directly as motions, and even if this does not hold for others, such as the stimuli of weight, smell and taste, we may nevertheless assume that these stimuli evoke or change sensations only by causing or changing some kind of activity within our body." Fechner, *Elements of Psychophysics* (1860), trans. Helmut Adler (New York: Holt, Rinehart, 1966), p. 19. The work of Ivan Sechenov, who worked briefly under Helmholtz in 1858, is also pivotal for its account of "reflexes which begin with sensory stimulation, continue in the shape of a definite psychical act and end in muscular movement"; and for Sechenov, an *involuntary* visual attention was one of the most basic of these acts. See his *Reflexes of the Brain* (1863), trans. S. Belsky (Cambridge: MIT Press, 1965), p. 43. Sechenov insists that visual attention does not depend on will: "Consequently, the primary act of vision even in the adult is involuntary. . . . The structure of the optical membrane, certain parts of which perceive light better than the other parts, is responsible for another involuntary act, the psychical aspect of which, in its highest degree, is described as 'attention in the sphere of visual sensations.' It is expressed by the clarity of perception of the image on which the attention is focussed (at which the person is looking, or to which his optical axes are directed), as well as by the decline in sensibility to the surrounding objects sometimes resulting in their complete disappearance from the field of vision." (Ibid., p. 48.) On the historical background of Sechenov's work, see M. Peter Amacher, "Thomas Laycock, I. M. Sechenov and the Reflex Arc Concept," *Bulletin of the History of Medicine* 38 (1964), pp. 168–183.

attempted, whether successfully or not, to induce different emotional and physical responses) involved *the aim* of engaging much more than the exclusively optical consciousness of the individual human subject and of producing effects involuntarily or even automatically. Regardless of whether this subject is finally “active” or “reactive,” Seurat’s project nonetheless challenged the privileged status of a *conscious* observer.

By the mid-1870s, well before Henry’s formulations, such ideas had become central elements of even mainstream aesthetic thinking. For example, the widely read *Esthétique* of Eugène Veron described aesthetic response in terms of reflex action, excitation, and contraction of muscles, and of particular lines and colors producing predictable physiological responses. An editor of the conservative periodical *L’Art*, Veron described “the transmission of excitation from one part of the nervous system to another” and stated that such effects occurred “absolutely independent of our will.”⁴² What is important here are its consequences for the status of perception: it is a model in which what previously had been exclusively in the domain of the optical (whether conceived as light rays, light waves, or luminous energy) is now part of a different system of effects and relations.⁴³ In a sense it is a new metaphoric understanding, “a complete overleaping of one sphere, right into the middle of a new and entirely different one.”⁴⁴ Light no longer leads primarily to the formation of images but to changes in the body, to redistributions of energy within an active, mobile subject.

William James discussed dynamogeny in his *Principles of Psychology*, a text that helped diffuse the term to both specialist and general audiences in Europe

42. Eugène Veron, *L’esthétique* (Paris: C. Reinwald, 1878), pp. 371–372. A related group of ideas, linking aesthetic pleasure to the automatic functioning of the nervous system, had been developed the year before in Grant Allen, *Physiological Aesthetics* (London: H. S. King, 1877).

43. John Dewey was to outline one of the most influential anti-optical aesthetic positions in his *Art as Experience* (1932; New York: Perigee, 1980), and Seurat’s neoimpressionism provided him with a crucial model (p. 122): “When some painters introduced the ‘pointillist’ technique, relying upon the capacity of the visual apparatus to fuse dots of color physically separate on the canvas, they exemplified but they did not originate an organic activity that transforms physical existence into a perceived object. But this sort of modification is elementary. It is not just the visual apparatus but the whole organism that interacts with the environment in all but routine action. The eye, ear, or whatever, is only the channel *through* which the total response takes place. A color as seen is always qualified by implicit reactions of many organs, those of the sympathetic system as well as of touch. It is a funnel for the total energy put forth, not its well-spring. Colors are sumptuous and rich just because a total organic resonance is deeply implicated in them.”

44. See the extraordinary discussion of metaphor formation and perception in Nietzsche, “On Truth and Lies in a Nonmoral Sense,” in *Philosophy and Truth*, trans. Daniel Breazeale (Atlantic Highlands, N.J.: Humanities Press, 1979), pp. 79–100.

and North America. James affirmed the same holistic account of the nervous system that had been an important part of the work of Brown-Sequard, whose lectures James had attended at Harvard in the late 1860s.⁴⁵ Both were parties of the camp which stressed that the nervous system is not simply an accumulation of local reflexes and circuits, and that because of the immense number of interconnections, reciprocal influences or reverberations of one part on another will always be a factor. Thus for James, dynamogeny was one example of how kinesthetic sensation affected the total creative behavior and emotional state of the individual, rather than being simply a localized physical event. Influential in terms of sheer readership was the two-volume *Handbook of Psychology* by the American James Mark Baldwin. This widely used textbook outlined a “Law of Mental Dynamogenesis” which proposed that “every state of consciousness tends to realize itself in an appropriate muscular movement.”⁴⁶ Also, the widely read pseudo-psychology of Herbert Spencer contained a general “aestho-physiology” that explained emotions and conscious states in terms of “simulations and discharges of nerve-force reverberating throughout the nervous system,” which was thoroughly compatible with the idea of dynamogeny.⁴⁷ By the late 1880s it had already acquired a wider cultural set of meanings associating it with any stimulus or event that produced a generalized surge of life-enhancing feelings. Max Nordau, writing about modern warfare, describes (well before Marinetti and Ernst Junger) the result of victory in battle: “The feeling of triumph is one of the most pleasurable the human brain can experience and the force-producing, ‘dynamogenous,’ effect of this pleasurable feeling is well qualified to counteract the destructive influences of

45. See William James, *The Principles of Psychology* (1890; New York: Dover, 1950), vol. 2, pp. 379–381. James indicated various ways in which a system-wide muscular contraction was either weakened or increased by various sensations, noting, for example, that when musical notes “are compounded into sad strains, the muscular strength diminishes. If the strains are gay, it is increased,” and he remarked on the powerful “dynamogenic value” of the color red. On the importance of Brown-Sequard to the formation of James’s thought, see Eugene Taylor, “New Light on the Origin of William James’s Experimental Psychology,” in Michael G. Johnson and Tracy B. Henley, eds., *Reflections on “The Principles of Psychology”* (Hillsdale, N.J.: Erlbaum, 1990), pp. 33–62.

46. James Mark Baldwin, *Handbook of Psychology: Feeling and Will* (New York: Henry Holt, 1891), pp. 280–282. The English psychologist and editor of *Mind*, George Frederick Stout, discusses how “dynamogenic” effects increase the vigor of the nervous system in his influential *Analytic Psychology*, vol. 2 (London: Sonnenschein, 1896), p. 302. As late as 1911, a standard American textbook discussed reflex theory with reference to dynamogeny and the work of Fere, in George T. Ladd and Robert S. Woodworth, *Elements of Physiological Psychology*, new ed. (New York: Scribner’s, 1911), pp. 532–535.

47. See Herbert Spencer, *The Principles of Psychology*, 3d ed., vol. 1 (New York: D. Appleton, 1871), pp. 97–128.

the impressions produced by war."⁴⁸ It suggests the possibility of managing behavior by producing effects of "enhancement" to counteract the opposing effects of certain stimuli in order to insure specific performance parameters. At the same time, the details of certain accounts of dynamogeny suggested that a model of sexual response, applied to the entire organism, was being used to describe nervous activity of many kinds: a sudden heightening of sensation or tension, accompanied by vasocongestion in localized areas of the body.⁴⁹ But it was also an instrumental and reductive way to conceptualize and control the potential disorder of a body, whose different regions were traversed by varying intensities of energy. As I will explore later in this chapter, Seurat's work is a model of response that held at least the promise or dream of a fully unalienated, instinctual aesthetic gratification, yet could only be imagined through the impoverished systematizing of drive or of affect into a quantifiable and manageable economy of excitation, within an "organized" and controllable body.

This dimension of Seurat's work has long been associated with various late-nineteenth century manifestations of "biological romanticism" and vitalism, including art nouveau and empathy theory.⁵⁰ But in addition to Seurat's, one of the most notable (and ambivalent) responses to the same body of ideas is in the late work of Nietzsche. In spite of his suspicion of experimentalist, evolutionist, or other "reductionist" forms of knowledge, Nietzsche read fairly widely in contemporary scientific literature.⁵¹ One book he encountered, probably in late 1887 soon after its publication, was Charles Fere's *Sensation et mouvement*. He no doubt read it within the frame of his meditations on the fate of European culture, through his

48. Max Nordau, *Degeneration* (1892; New York: Appleton, 1895), pp. 207–208. Ironically, it was through Nordau's book that filmmaker Sergei Eisenstein later drew on Fere's ideas, to affirm the "dynamogenous" effects of various sense impressions, in *The Film Sense*, trans. Jay Leyda (New York: Harcourt, Brace and World, 1947), pp. 145–146. Eisenstein and Seurat can be associated as artists who struggled to reconcile rational formal clarity with techniques for stimulating emotional response. See the characterization of Eisenstein's work in Peter Wollen, *Signs and Meaning in the Cinema* (Bloomington: Indiana University Press, 1969), pp. 19–73.

49. The concrete application of a sexualized model of dynamogeny is evident in Brown-Séquard's unusual attempts to induce dynamogenic effects in human subjects by injecting "testicular fluids" under the skin. This experiment is reported in Charles Fere, "L'énergie et la vitesse des mouvements volontaires," *Revue philosophique* 28 (July–December 1889), p. 68. See also the account of such experiments, including Brown-Séquard's own self-injections, in Ellenberger, *The Discovery of the Unconscious*, p. 295.

50. The notion of *Einfühlung* in the work of Lipps and others poses a related, though certainly less materialist, model of attention. In empathy theory, *Einfühlung* described a mode of intense perceptual absorption in which lines and forms were experienced by the subject as specific motor sensations, and were the catalyst for a vitalization of the imagination.

51. For an inventory of books on science and physiology in Nietzsche's library see "Friedrich Nietzsches Bibliothek," in *Bücher und Wege zu Büchern* (Berlin: W. Spemann, 1900), pp. 437–438.

own uncertainty about whether the “manifoldness and unrest” of the late nineteenth century were conditions for a new ascent of culture or were more powerfully linked to pathological exhaustion (and also through his personal anxiety about “overstimulation” and its effects on his own fragile health). Paradoxically, Nietzsche deplored the automaton-like or reflex character of contemporary existence (life as adaptation, decadence as a physiological condition), even as he identified the primal “reality of our drives” and valued action or states that eluded a rational ego and had a powerful automatic character.⁵² Nietzsche could distinguish without hesitation between those forms of *thought* which he called reactive and active; but it was more difficult for him to make decisive evaluations within the concrete forms of material life and culture reshaping the face of Europe (for example, his uncertainty about which contemporary forms of illusion were life-affirming and which were base and trivial). So what is his response to Fere’s account of “psycho-motor induction”? Of course for Nietzsche it is a crude formulation, but also perhaps redolent enough of his own postulation of an art not confined to representation but that would “exercise the power of suggestion over the muscles and the senses,” that would communicate movements rather than thoughts.⁵³

In these late notes, Nietzsche provides piercing glimpses of an aesthetic treatise never to be completed, although there is little doubt about the persistence with which he insisted on aesthetic experience that was a feeling of increased energy and plenitude.⁵⁴ He builds on an image already articulated a few years earlier: “A living thing seeks above all to *discharge* its strength.”⁵⁵ In the *Will to Power* he lists the physiological states native to the artist: “One must first think of this condition as a compulsion and urge to get rid of the exuberance of inner tension through muscular activity and movements of all kinds; then as an involuntary coordination between this movement and the processes within (images, thoughts, desires)—as a kind of automatism of the whole muscular system impelled by strong stimuli from within—; inability to prevent reaction; the system of

52. Friedrich Nietzsche, *Beyond Good and Evil* (1886), trans. Walter Kaufmann (New York: Random House, 1966), p. 47.

53. Friedrich Nietzsche, *The Will to Power* (1888), trans. Walter Kaufmann (New York: Random House, 1967), p. 427 (sec. 809).

54. Nietzsche had tentatively sketched out a section in the fragments of *The Will to Power* titled “Toward a Physiology of Art.” He briefly describes some of its aims in *The Case of Wagner* (1888), trans. Walter Kaufmann (New York: Random House, 1967), p. 169. See the related discussion in Martin Heidegger, *Nietzsche*, vol. 1: *The Will to Power as Art*, trans. David Farrell Krell (New York: Harper and Row, 1979), pp. 92–106.

55. Nietzsche, *Beyond Good and Evil*, p. 21; emphasis in original.

inhibitions suspended as it were. Every inner movement (feeling, thought, affect) is accompanied by vascular changes and consequently by changes in color, temperature and secretion.”⁵⁶ When he refers to “inner movement” and “processes within,” he is attempting to express the idea of a force that cannot be understood mechanistically, of a force that initiates and imposes itself through its own inner dynamism. Nietzsche’s “physiology” here has little in common with the tedious biometric imperatives of Fere’s work; yet the binary system of dynamogeny and inhibition was clearly a figuration of the richer (and immeasurable) energies that Nietzsche intuited at work within the subject.⁵⁷ It is merely another image of *two types of force* that Nietzsche endlessly recast into active and reactive, strong and weak, ascending life and decadence, forgetfulness and memory. But central to his late thought was the distinction between contemporary *mechanistic* conceptions of force and his own dynamic model of a “will to power,” in which the play of forces constituted an inner dynamic capable of creating, of initiating something new. When Fere declares that dynamogenic sensations of pleasure are inseparable from a sensation of power, it is for Nietzsche merely a confirmation from another (lower) vantage point that “the condition of pleasure called rapture is precisely an exalted feeling of power . . . ‘intelligent’ sensuality—; strength as a feeling of dominion in the muscles, as suppleness and pleasure in movement.”⁵⁸ At the same time Nietzsche is contemptuously dismissing reductive Darwinian postulations that instinctual behavior must be understood in terms of mere preservation or survival of the organism.

And if we can draw a diagonal from Seurat (through Féré) to Nietzsche, it is finally because for both of them the question of meaning in art was not about representation but a relation of forces, and that art is not a semiology but a physics. Color for Seurat was not something accessible as a sign to a sovereign gaze but

56. Nietzsche, *The Will to Power*, pp. 428–429 (sec. 811).

57. Attention, of course, is inseparable from what Nietzsche called “the reality of our drives,” inseparable from the libidinal body of Freud’s work. John Rajchman has cogently reminded us that the “libidinal body is not the same thing as the anatomical or physiological body, and has another sort of relation to our living. Nor is the libidinal body the instinctual body. For ‘drives,’ unlike instincts are not tied to specific conditions of satisfaction, but are submitted to an open-ended ‘plasticity,’ ever susceptible to ‘substitutions’ in their objects and aims. Our drives are constantly missing their aims and deviating from their objects, and that is why our ‘desire’ is not a ‘need’ identifiable by what satisfies it.” Rajchman, *Truth and Eros* (New York: Routledge, 1991), p. 33.

58. Fere, *Sensation et mouvement*, pp. 66–68; Nietzsche, *The Will to Power*, pp. 420–421 (sec. 800). Following more recent translators, I have modified Kaufmann’s rendering of Nietzsche’s “Rausch” from “intoxication” to “rapture.”

was an interpretation made by the body, an instance of what Nietzsche described as our drives interpreting the world.⁵⁹ Experience for both Seurat and Nietzsche is never unified but always a multiplicity of conflicting impulses, and the quality of this experience is only a differential of the quantity of two forces. Seurat's elusive goal of Harmony was, in the late 1880s, a question of a relative equilibrium of forces, never a fixed set of formal or binary relations as is so often claimed. Of course the whole rhetorical terrain of stimulation, of dynamism, of Henry's and Fere's sensations of power and strength, seems alien and remote from the apparent serenity and "classicism" of so many of the paintings in question, whether *Parade de cirque* or the late seascapes from Gravelines.⁶⁰ But Seurat may well have sensed, as had Nietzsche, that there was an "extreme calm in certain sensations of rapture (more strictly the extreme retardation of the feelings of time and space). . . . The classical style is essentially a representation of this calm, simplification, abbreviation, concentration—the *highest feeling of power* is concentrated in the classical type. To react slowly; a great consciousness, no feeling of struggle. . . . Logical and geometrical simplification is a consequence of enhancement of strength."⁶¹

The question about the nature of the human subject presupposed by Seurat's practice remains unanswerable in any definitive form. To what extent can we characterize this subject, in Nietzschean terms, as merely *reactive*? On one hand Seurat is clearly comfortable working within a discourse derived from empirical research on what are essentially stimulus-response mechanisms, a set of related techniques for the external management of aesthetic response, that are ultimately a kind of quantifiable emotional engineering. Is Seurat's spectator a being that is acted upon, that in a sense "obeys" a predetermined program of effects? Or is this physiological subject a body that creates, invents, and affirms? But these questions presuppose a subject that is a unity, with a conscious will to be overcome. Is a work like *Parade de cirque* merely an activation of forces whose effects depend on the

59. Nietzsche, *The Will to Power*, sec. 481.

60. At the same time it is hardly a question of a literal setting in motion of the body that would be evident externally. The "motricity" of Seurat's spectator is closely related to Christian Metz's account of the filmic spectator for whom the "institutional situation of the spectacle inherently prevents motor conduct from following its normal course very far." For Metz, the conditions of attentive filmic spectatorship are related to both dreaming and sleep in that motor activity, instead of being directed out into the world, has "a greater tendency to flow back towards the perceptual outlet. . . . It will turn back in the direction of the perceptual agency, to take the regressive path, to busy itself with hypercathecting perception from within." Metz, *The Imaginary Signifier*, trans. Celia Britton et al. (Bloomington: Indiana University Press, 1982), pp. 116–118.

61. Nietzsche, *The Will to Power*, p. 420; emphasis in original.

particular and shifting balance of physical responses within each individual observer? And was part of that free play the production of “intensified life, an enhancement of the feeling of life”?⁶²



Alongside the hypothetical individual observer who is the object of Seurat’s method, *Parade de cirque* contains a schematic figuration of a collective subjectivity, seemingly characterized by automatic behavior and whose attentiveness is inseparable from the vacancy of spectacle. In this sense the onlookers at the bottom of the painting are much more than simply pictorial surrogates for an external spectator; they stand here as potential objects of techniques for the control and management of perception and attention. Most of Seurat’s major works make this clear: how a sensory world is dismantled, resynthesized, and represented is inseparable from the problem of how a world of objects, individuals, and social relations organizes itself. His paintings are collections of hypotheses about how elements or things can be combined, of how various aggregates are produced (or dissolved) by different formal operations. What concerns Seurat, whether in terms of individual touches of color or images of human figures, is a tension between cohesion and disintegration. This is evident whether it is a question of how diverse stimuli become tentatively “bound” into a coherent constellation or how contents referring to a social world are fused or integrated into a network of relations. The effectiveness of *Parade de cirque* is inseparable from the movement between these two diagrammatic levels.

Seurat was one of many at this time whose work investigated the connection between the relative unity of subjective experience and the integrity of social institutions and processes. For figures like Charles Henry and Charles Fere, the phenomena of reflex responses and the operation of the nervous system were hardly just a matter of physiological knowledge. The paramount consideration was the maintenance of social order and equilibrium, and an excess of sensory stimulation was potentially disruptive or pathological. Thus for Henry and others, a scientific aesthetic suggested the possibility of producing “agreeable” nervous and psychic states compatible with social tranquillity and economic productivity. Fere was one of many preoccupied with the contemporary social fantasy of “solidarity,” and he cautioned against the dangers of collective overstimulation, sociopathic exhaustion and ultimately of degeneration, which threatened the health and functional

62. Ibid., p. 422 (sec. 802).

unity of solidarity.⁶³ Another influential figure in these issues was Jean-Marie Guyau, who in the late 1880s studied how the physiological nature of individual perception affected the functioning of social collectivities. Féré in fact cited Guyau's work as confirmation of the social significance of a dynamogenic explanation of aesthetic pleasure: for Féré and many others, individual pleasure ought not to exceed limits beyond which the long-term evolutionary interest of the collectivity were threatened.⁶⁴ Recent scholarship has shown how a significant body of French aesthetic theory, beginning in the 1880s and throughout the 1890s, increasingly addressed the nature of mass subjectivity and the relation between aesthetic perception and social integration.⁶⁵

Seurat, then, was working within a set of ideas that were as much social in their resonance as they were either "physiological" or aesthetic. But it would be a major misunderstanding to suggest that his work is part of a calculated project of producing "agreeable" psychic states in his spectators in the interests of social cohesion. Perhaps it would be more useful to consider that Seurat's balancing of dynamogenic and inhibitory effects in *Parade de cirque* produced, at least in theory, a harmonious equilibrium of psycho-kinesthetic response that was in some way a utopian projection of a sensory wholeness and fulfillment impossible within the dissonance of contemporary European culture. Certainly much of his work from Port-en-Bessin and Gravelines seems aligned with such a possibility: the finely ordered harbor scenes, with their evocation of a premodern relation of nature and culture, might have some visionary social potency.⁶⁶ But even if there is

63. In 1894 Henry declared, "That which science can and must do is to expand the agreeable within and outside of us, and from this point of view its social function is immense in this time of oppression and senseless conflict." Cited in Arguelles, *Charles Henry and the Formation of a Psycho-physical Aesthetic*, p. 84. See Charles Féré, "Degenerescence et criminalité," *Revue philosophique* 24 (October 1887), p. 357: "The need for excitement increases inversely to the weakening of the individual or race. Each new excitation is followed by a proportional quantity of exhaustion, of a sort which in the end precipitates degeneration."

64. See Jean-Marie Guyau, *L'art au point de vue sociologique* (Paris: Félix Alcan, 1889). Féré quotes Guyau in his *Sensation et mouvement*, p. 69. Nietzsche was familiar with some of Guyau's work from the early 1880s and was obviously interested in his assertion that the highest life is about feelings of abundance, strength, and "expansibilité," as well as his affirmation that instinct is more powerful than consciousness. On Nietzsche's reading of Guyau, see the study by the latter's stepfather, Alfred Fouillee, *Nietzsche et l'immoralisme* (Paris: F. Alcan, 1902).

65. See Nina Lara Rosenblatt, "Photogenic Neurasthenia," *October* 86 (Fall 1998), pp. 47–62.

66. These harbor paintings by Seurat, taken in this way, recall the remarks by Claude Lévi-Strauss on the eighteenth-century seaport paintings of Joseph Vernet: "For me, their value lies in the fact that they allow me to relive the relationship between sea and land which still existed at that time; a port was a human settlement which did not completely destroy, but rather gave a pattern to, the natural relationships between geology, geography and vegetation and thus offered an exceptional kind of reality, a

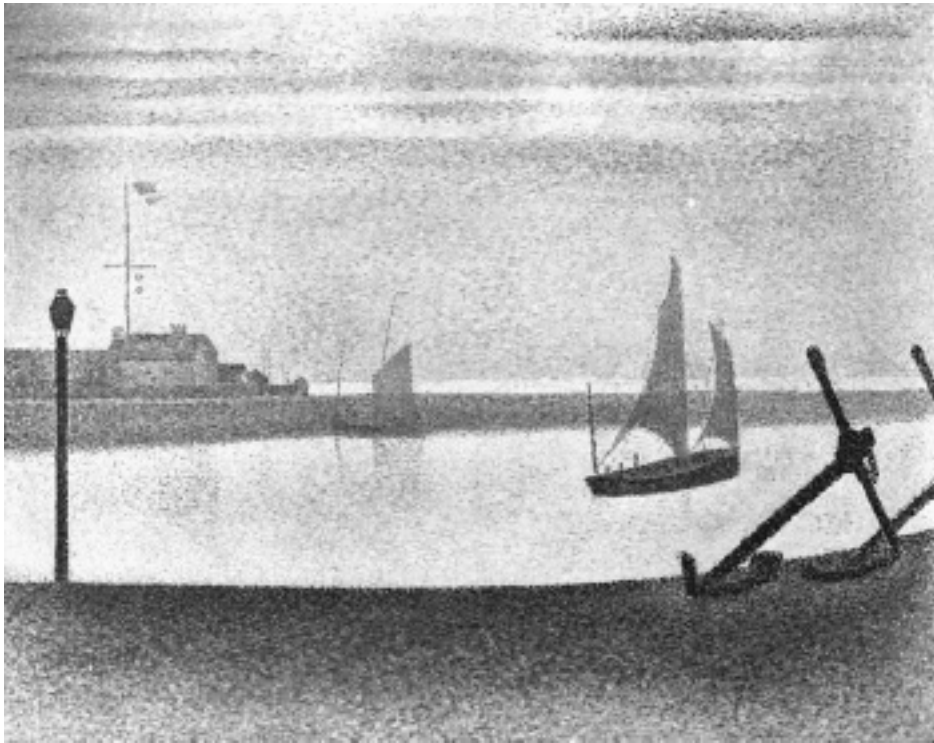

Georges Seurat, *The Channel at Gravelines, Evening*, 1890.

value in such an explanation, it cannot be reconciled with the problem of how the research on which Seurat relied was also fully part of institutional knowledge directed at the external control of subjective behavior and response. Nor does it suggest why such a figuration of harmony (“the analogy of opposites”) would overlap with the plainly ambiguous and even disturbing social content in *Parade de cirque* (and in *Cirque* as well).

This movement between the sensory and the social has affinities with the work of Seurat’s almost exact contemporary Emile Durkheim. No matter how ap-

dream world in which we can find refuge.” *Conversations with Claude Lévi-Strauss*, ed. G. Charbonnier, trans. John and Doreen Weightman (London: Grossman, 1969), p. 97. However, the rigorously depopulated ambience of Seurat’s paintings works against this reading. His one seaport image that includes human figures, *Port-en-Bessin: Le pont et les quais* (1888), is haunting for the starkness with which social isolation and distance is mapped out. See my remarks on these late marine paintings in my “Seurat’s Modernity,” in Ellen W. Lee, ed., *Seurat at Gravelines: The Last Landscapes* (Indianapolis: Indianapolis Museum of Art, 1990), pp. 61–65.

parently dissimilar their fields, both Seurat and Durkheim are related fabricators of powerful *imaginary* social figurations. They share a belief not only that science is a form of perception but that scientific procedures provide methods for the creation of new concepts and forms, and they stand for a shift in thinking from the study of elementary units to their rules of combination.⁶⁷ Both investigate how social and sensory elements combine or interact to form different sorts of aggregates, and both are concerned with how various syntheses produce *qualitative* transformations of the elements in question, whether these are social representations or sensory impressions. For both, it is a question of from what viewpoints significant manifestations of *organization* become apprehensible.

These questions, in relation to Seurat, are hardly new, and critics beginning with Meyer Schapiro and Ernst Bloch have looked at his paintings in these terms, evaluating the nature of the social aggregates that he assembles.⁶⁸ His handful of major works, including *La Grande Jatte* and *Cirque*, are diagrams of different kinds of social cohesion or dissolution, depending on one's political vantage point. *La Grande Jatte*, in particular, can be seen as an ambiguous puzzle, in Durkheimian terms, of the problematic nature of social *association*. Is the assemblage pictured here an image of harmony, to use a word privileged by both Durkheim and Seurat, the near-equilibrium state of solidarity, of individuals transformed into "social beings"? Or is it a statistical distribution of isolated and categorized units, the result of a merely additive principle of formal adjacency, in which depleted, anomic relations predominate beneath the spurious appearance of social concord?

67. Durkheim's own account of perception in the early 1890s shared some essential features with Seurat's dualistic dynamic model. Durkheim writes: "Every strong state of the consciousness is a source of life; it is an essential factor in our general vitality. Consequently all that tends to weaken it diminishes and depresses us. . . . In fact, a representation is not a simple image of reality, a motionless shadow projected into us by things. It is rather a force that stirs up around us a whole whirlwind of organic and psychological phenomena. Not only does the nervous current that accompanies the formation of ideas flow within the cortical centers around the point where it originated, passing from one plexus to another, but it also vibrates within the motor centers, where it determines our movements and within the sensorial centers where it evokes images." Durkheim, *The Division of Labor in Society* (1893), trans. W. D. Halls (New York: Free Press, 1894), p. 53. On science as a form of perception, see Paul Q. Hirst, *Durkheim, Bernard, and Epistemology* (London: Routledge and Kegan Paul, 1975), p. 104. For a recent discussion of Durkheim and perception, see Chris Jencks, "Durkheim's Double Vision," in Ian Heywood and Barry Sandywell, eds., *Interpreting Visual Culture: Explorations in the Hermeneutics of the Visual* (New York: Routledge, 1998), pp. 57–73.

68. See Meyer Schapiro, "Seurat and 'La Grande Jatte,'" *Columbia Review* 17 (November 1935), pp. 9–16; and Ernst Bloch, *The Principle of Hope*, vol. 2, trans. Neville Plaice et al. (Cambridge: MIT Press, 1986), pp. 813–817. See also Linda Nochlin, "Seurat's Grande Jatte: An Anti-Utopian Allegory," and Stephen F. Eisenman, "Seeing Seurat Politically," both in *Art Institute of Chicago Museum Studies* 14, no. 2 (1989), pp. 133–154 and 211–222; and T. J. Clark, *The Painting of Modern Life* (Princeton: Princeton University Press, 1984), pp. 263–267.



Georges Seurat, *Sunday Afternoon on the Island of La Grande Jatte*, 1884–1886.

Durkheim, in the 1890s, was concerned with new holistic models of association that would supersede those inflexible models of increasingly outdated associationist theories. His work entails a rejection of mere juxtaposition, and it poses synthesis as a dynamic and self-organizing process. It would not be unwarranted to link aspects of Durkheim's thought with early Gestalt theory: "A whole is not identical with the sum of its parts. It is something different and its properties differ from those of its component parts. . . . On the contrary, [association] is the source of all the innovations which have been produced successively in the course of the general evolution of things."⁶⁹ He developed analogies between physiological perception and the perception of social objects, insisting that each level was directed toward aggregates and wholes rather than atomized elements.⁷⁰ Durkheim's

69. Emile Durkheim, *The Rules of Sociological Method* (1895), trans. Sarah Solovay and John Mueller (New York: Free Press, 1964), pp. 102–103.

70. This is the central theme of his essay "Individual and Collective Representations" (1898), in which Durkheim engages the work of Janet, Wundt, and especially William James; in Durkheim, *Sociology and Philosophy*, trans. D. F. Pocock (Glencoe, Ill.: Free Press, 1953), p. 30: "The whole is only formed by the grouping of the parts, and this grouping does not take place suddenly as the result of a miracle. There is an infinite series of intermediaries between the state of pure isolation and the completed state

method involved a reorientation of attention, away from isolated or individual units toward the apprehension of larger aggregates, and his rejection of a psychology of individuals in favor of a “science of society” is implicit in this shift.

For Durkheim modernity is a qualitatively new phase in the history of human existence, but what specifically distinguishes it is the emergence of new kinds of human aggregates, in a sense new manifestations of complexity.⁷¹ Durkheim attempts, as Seurat in his own fashion also does, to characterize modern forms of social cohesion—by asking what it is that holds together the diverse elements of a society given the absence of relatively inflexible traditional forms such as religion, myth, and consanguinity. The answers to this question are inseparable from the way in which both *Parade de cirque* and *Cirque* are historically meaningful. “Organic solidarity” has the flexibility of a living system (in contrast to the “mechanical solidarity” of traditional society) in which vast numbers of differentiated individuals, composing many subsystems, cohere into one intricately functioning organism. Alienation and isolation are overcome by individuals understanding their necessary integration into self-regulating, interlocking feedback loops. Yet Durkheim’s work presents a fraudulently harmonious vision of industrialized society when high capitalism was taking shape in the late nineteenth century, and it attempts to validate a relatively stable and domesticated image of the dynamism and destructiveness of capital. Although insisting on growth and development as fundamental features of a social organism, Durkheim’s account of modernity is about a state of “equilibrium.” His postulation of the “organic solidarity” of modernity was just such a state of harmonious equilibrium in which, through legal rules, social conventions, professional organizations, and ultimately the state, human beings interact in relations of agreement and mutual sacrifice, a stable temporal order that Auguste Comte had earlier begun to outline. As François Ewald has shown, the

of association. But as the association is formed it gives birth to phenomena which do not derive directly from the nature of the associated elements, and the more elements involved and the more powerful their synthesis, then the more marked is this partial independence.” Recently it has been noted that “this whole essay underlines the great interest Durkheim took in the debates and developments in psychology in the 1890s; indeed that he taught courses in psychology at Bordeaux is often forgotten or overlooked. Far from adopting ‘crude’ or ‘naive’ views on the nature of the individual, Durkheim’s position was abreast of the major developments at the decisive moment of the formation of modern psychology.” Mike Gane, *On Durkheim’s Rules of Sociological Method* (New York: Routledge, 1988), p. 31.

71. Some of Durkheim’s “organicist” formulations (i.e., positing a continuity between biological and social entities) seem less retrograde than they might have several decades ago. His description of the evolution of human societies is very much as a self-organizing process, defined by threshold moments in which constellations of previously disconnected elements unexpectedly begin to interact to form a new higher-level entity or organism. This is especially the case in his account of the shift from the segmented societies characterized by “mechanical solidarity.”

notion of “solidarity” implied a new set of moral imperatives, the duty to become a “social being,” to become *socialized* in relation to a wide range of institutions.⁷²

In the 1890s Durkheim sought to explain how the division of labor which he believed essential to social vitality and moral order could at the same time be the cause of dissipative and pathological effects. The division of labor was a process that could not “be pushed too far without being a source of disintegration.”⁷³ Durkheim returned to Comte for a vocabulary to elaborate the effects of anomie—decomposition, dispersion, dissolution—all of which describe how certain patterns and networks of social organization are disrupted.⁷⁴ Anomie, in this sense, is a *formal* concept. That is, anomie designates a breakdown of an organized set of connections and adjacencies and deranges a normally regulated flow of communication and feedback. “A state of anomie is impossible wherever organs solidly linked to one another are in sufficient contact.” Durkheim insisted that “if the division of labor does not produce solidarity it is because the relationships between the organs are not regulated.”⁷⁵ Anomie, in a celebrated passage, is when the individual worker “is no longer the living cell of a living organism, moved by continual contact with neighboring cells, which acts upon them and responds in turn to their action, extends itself, contracts, yields and is transformed according to the needs of the circumstances. He is no more than a lifeless cog, which an external force sets in motion and impels always in the same direction and in the same fashion.”⁷⁶

Of course Durkheim tried hard to portray such social dissolution as part of a *transitional* phase, rather than as a permanent feature of a system that would, by its very nature, always be in transition. Because the transformations of modernization had occurred with such rapidity, “the conflicting interests have not had time to strike an equilibrium.”⁷⁷ His model of modern organic solidarity is linked both

72. See François Ewald, *L'Etat providence* (Paris: Grasset, 1986), pp. 364–367. Charles Fere, for example, had written in 1887: “A society can have no other durable foundation than solidarity.” Fere, “Degenerescence et criminalite,” p. 337.

73. Durkheim, *The Division of Labor in Society*, p. 294.

74. *Ibid.*, p. 295. Jean Duvignaud emphasizes the creative possibilities that are opened up by states of anomie: “The facts of anomie constitute a passage from one phase to another, from the systematic structure of language to a condition of non-structure that momentarily abolishes all established congruence and opens up a chasm, an illumination at the heart of established discourses. And this is independent of the disorder that inevitably provokes the collision, confusion and short-circuiting between different languages and series.” Duvignaud, *L'anomie: Heresie et subversion* (Paris: Editions Anthropos, 1973), p. 86.

75. Durkheim, *The Division of Labor in Society*, p. 304.

76. *Ibid.*, pp. 306–307.

77. *Ibid.*, p. 306.



Georges Seurat, Solitary Figure, 1883.

to the healthy complexity of a higher organism and to the near-equilibrium of a thermodynamic system. Within a thermodynamic framework, anomie and solidarity can be posed as two different kinds of statistical information about large aggregates of elements. Just as James Clerk Maxwell rejected a dynamical or “historical” account of the activity of individual molecules, so Durkheim renounced the individual as a unit of study in favor of collective regularities.⁷⁸ Anomie then describes a statistical distribution of elements in which insufficient contact or adjacency prevents the flow of messages or information within the system as a whole.⁷⁹ Without pushing this comparison too far or developing the homologies between anomie and entropy, it could be said that Durkheim saw the transmission of messages as

78. See P. M. Harman, *Energy, Force and Matter: The Conceptual Development of Nineteenth Century Physics* (Cambridge: Cambridge University Press, 1982), pp. 131–134.

79. This general formulation recurs throughout the twentieth century; for example, in the urban thinking of Christopher Alexander: “In any organized object, extreme compartmentalization and the dissociation of internal elements are the first signs of coming destruction. In a society, dissociation is anarchy. In a person, dissociation is the mark of schizophrenia and impending suicide.” Alexander, “A City Is Not a Tree, Part 2,” *Architectural Forum* 122, no. 2 (May 1965), p. 61.

a measure of the relative organization or disorganization of society.⁸⁰ If anomie, as a systemwide increase in local zones of dissociation and disintegration, is related to a failure of feedback processes, the anomic individual, described above, closely resembles in its functioning an automaton, in which the resilient adaptability of a living organism is supplanted by the repetitive pattern of machinic behavior.⁸¹ It is here that modern forms of attention, isolating and quasi-automatic, are intertwined with what Durkheim sought to explain as “anomie.”

Durkheim’s diagnosis of a crisis of social “disaggregation” reinforced his preoccupation with forms of binding and cohesion, just as Pierre Janet and others were studying psychic disaggregation and the mechanisms of cognitive and perceptual synthesis. But Durkheim’s palatable vision of a smoothly functioning (future) society of individuals working cooperatively within state-dominated corporate entities had little to do with the actual pseudo-solidarities that were taking shape in those years. Behind this phase of Durkheim’s work was the need to conceal or repress the omnipresent separations and segmentations produced by modernization.⁸² In a certain way Durkheim’s claim that he is writing about a crisis of social cohesion within a transitional period was correct, but one of the actual systemic responses to this crisis was only just taking shape within his lifetime (a response we see foreshadowed in several of Seurat’s major works)—the making of a society whose effective unity was founded on the ubiquity of spectacular consumption through mass media and technologies of illusion. If religion was the key “collective representation” within Durkheim’s premodern mechanical solidarity, the spectacle, as “a specious form of the sacred,” was to become the primary simulation of cohesion and unification within twentieth-century modernity.⁸³ De-

80. Traditional accounts of Durkheim often conflate the ethical and economic effects of “message transmission,” thus naturalizing the intensification of circulation under capitalism. See, for example, Raymond Aron, *Main Currents in Sociological Thought*, vol. 2, trans. Richard Howard and Helen Weaver (New York: Basic Books, 1967), p. 23: “Moral density, it seems to me, is roughly the intensity of communication between individuals, the intensity of intercourse. The more communication there is between individuals, the more they work together, the more trade or competition they have with one another, the greater the density.”

81. On the relation between organism and automaton, see Norbert Wiener, *The Human Use of Human Beings: Cybernetics and Society*, 2d ed. (Garden City, N.Y.: Doubleday, 1954), pp. 25–36.

82. According to Michel Foucault, Durkheim’s thought does not admit the existence of social mechanisms of *exclusion*. Durkheim’s sociology can only ask: “How can society hold individuals together? What is the form of relationship, of symbolic or affective communication that is established among individuals? What is the organizational system which permits society to constitute a totality?” “Michel Foucault on Attica: An Interview,” *Telos* 19 (1974), p. 156.

83. Debord, *The Society of the Spectacle*, p. 20. See Daniel Dayan and Elihu Katz, “Articulating Consensus: The Ritual and Rhetoric of Media Events,” in Jeffrey C. Alexander, ed., *Durkheimian Sociology: Cultural Studies* (Cambridge: Cambridge University Press, 1988), pp. 161–186.



Georges Seurat, Place de la Concorde, Winter, 1882-1883.

bord's *Society of the Spectacle* can stand for the final implosion and dismantling in the 1960s of the sociological tradition that issued from Durkheim, in Debord's insistence that the only solidarity produced by capitalism is a unity of subjects in their very separateness.

Surveying Seurat's entire visual output, both paintings and the much larger body of drawings (especially ones that are not obviously studies for larger works), it is impossible not to be struck by the endless and even systematic movement between the large engineered representations of social collectivities (or crowds) and the far more numerous images of isolation and separation. In the same way that the unity of his optical aggregates was always an ephemeral subjective construction that never objectively modified the abstract and segmented status of his dots, so his assembling of provisional social aggregates never alters the obdurately insular character of their individual human components. But even if Seurat's "sociology" is embedded within certain technical and rule-governed procedures, he nonetheless stakes out a darker and more skeptical position than Durkheim about

the possibility of positive knowledge of “social reality.” Thus, more than representations of anomie or class conflict, his works are determined by a sense of the impalpability and evanescence of the social itself.

As many have suggested, the emergence in the 1890s of a “science” of sociology, especially in France, is a sublation of the great social catastrophes of the nineteenth century and a compensatory product of the accumulated bourgeois anxiety over the disorders of the Revolution, the events of 1848, the 1871 Commune, and other upheavals. Seurat’s response to this legacy of turmoil is disturbingly revealed in a drawing from around 1883, *Place de la Concorde, Winter*. Here this bleak depopulated night world becomes a piercing negative image of the revolution so closely associated with this Parisian site. No architectural facades are visible amid the wintry desolation, and the actual obelisk at the center of this urban space, with all its mnemonic resonances, is decisively excluded from view. Instead, the banality of a lamppost anchors the scene, and only a partial silhouette of one of the two Hittorff fountains, at the left of the drawing, suggests the north-south axis on which the monumental obelisk stands. The carriage at the right, a ubiquitous fiacre, with its physical separation of driver and passenger, marks the class division on which the unbearable emptiness of the scene is founded. *Place de la Concorde* discloses the actual nightmare, the disorientation of a present in which the collective dreams of *egalite*, of *bonheur*, can no longer even be remembered. A decade or more after the Commune, it is not only a question of the repression of a field of hopes and anticipations but of the evacuation of the terrain on which they might once have been symbolically enacted.⁸⁴ *Place de la Concorde* points back to an earlier model of political theater, which is displaced by the modernized forms of spectacle that emerge in the last years of Seurat’s brief life.⁸⁵



The conceptual, technical, and representational strategies of Seurat’s late work are anticipations of the objects and forces that would become key compo-

84. See Denis Hollier, *Against Architecture*, trans. Betsy Wing (Cambridge: MIT Press, 1989), p. xxii: “For the first half of the nineteenth century, this esplanade was a source of uneasiness for developers and city planners. Should it be made into a place of memory and expiation or one of laughter and forgetting? How should one walk, with what sort of tread, where blood—including the king’s—had run? Taking advantage of this indecision, fairs and festivals temporarily set themselves up on this quasi-wasteland.” See also the account of the tangled symbolic uses of the Place de la Concorde during the Second Empire, in Matthew Truesdell, *Spectacular Politics: Louis-Napoleon Bonaparte and the Fete Imperiale, 1849–1870* (Oxford: Oxford University Press, 1997), pp. 17–26.

85. See the discussion of “theatrical depoliticization” in Andrew Hewitt, *Fascist Modernism: Aesthetics, Politics, and the Avant-Garde* (Stanford: Stanford University Press, 1993), pp. 164–172.



Georges Seurat, *Parade de cirque*, 1887–1888.

nents of new operations of social power in the early twentieth century.⁸⁶ Seurat discloses ways in which individuals, in their status and capacities as observers, can be assembled into new pseudo-solidarities, whether as crowds or audiences, even while maintaining their effective isolation. The painting reiterates on the level of content what it produces through its technical system: the work is a solicitation of attention. The sideshow, with its musicians and performers, is a device of *attraction*, meant to focus the attention of urban strollers and to persuade them to buy a ticket for access to the “main” attraction in the tent in front of them. But it is an attraction that will forever be withheld from them, from us, for this is a painting fundamentally designed around the cancellation and suspension of what it

86. On Debord and the “origins” of the society of the spectacle, see my “Spectacle, Attention and Counter-memory,” *October* 50 (Fall 1989), pp. 97–107.



Photograph of circus tent with sideshow platform, Paris, late 1880s.

promises to reveal. The spectator of this painting, both as individual and as part of a collective subjectivity, is inescapably implicated in its perpetual play of attraction and absence.

One of the most important features of *Parade de cirque* is how its formal organization destabilizes the position and identity of its presumed spectator. At the heart of this organization is Seurat's obliteration of the *scenographic* conditions of the work even as he simulates their persistence. The ostensible subject of the work is potentially *scenic* in more than one way: not only does it show a quasi-theatrical performance, but it positions its viewer as part of an audience before an apparently stagelike space.⁸⁷ It mimics a classically represented theatrical space while in fact withholding the essential elements of that signifying model: a model which, in principle, establishes an illusory world extending away from the spectator at the divide of the proscenium, yet a world reciprocally related to the viewer's own point of view. One of the most obvious structural features of *Parade de cirque* is the radical elimination of orthogonals and the resultant breakup of the painting

87. One of the exemplary accounts of the "cubical, unitary framework of classical scenography" in Renaissance painting is in the work of Pierre Francastel. See, for example, his *Etudes de sociologie de l'art: Creation picturale et société* (Paris: Denoel, 1970), pp. 191–197.

F. 12.

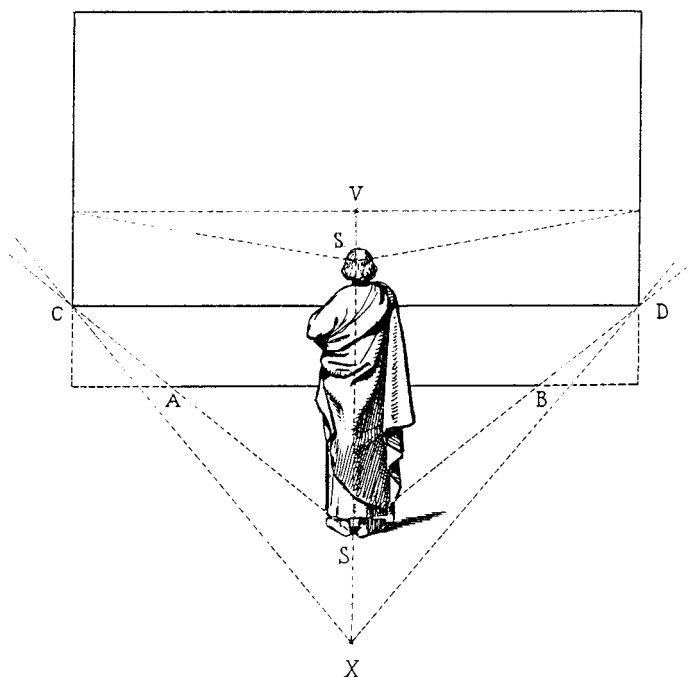

Illustration from David Sutter, *Nouvelle théorie simplifiée de la perspective*, 1859.

into an assemblage of disjunct planar elements.⁸⁸ Seurat's refusal of any orthogonal guides, of almost any foreshortening or recession indicators to aid us in construing spatial relations within the painting, has the effect of collapsing the "stage" area above the spectators into a single patchwork screen and of dramatically sealing off possible avenues of entry into the work for our eye. It is as if, in *Parade de cirque*, he simulated David Sutter's 1859 diagram of the perspectival relation between spectator and a rectangular tableau, but obliterated the determinate system of orthogonals on which its intelligibility depended.⁸⁹ At the same time this formal decision prevents the appearance of any planes or surfaces perpendicular to the picture plane. Thus we are denied one of the key elements that determined the

88. I have discussed certain forms of nineteenth-century imagery as aggregates of dissociated planar elements, in particular the stereoscope, in my *Techniques of the Observer: On Vision and Modernity in the Nineteenth Century* (Cambridge: MIT Press, 1990), pp. 124–126.

89. Sutter, *Nouvelle théorie simplifiée de la perspective*.

coherence of classical scenography: we cannot see the literal location of figures on the surface of the stage or on the “checkerboard” ground of perspectival painting. None of the figures in *Parade de cirque* are “grounded” in any visibly legible way. This is especially true of the central trombone player, whose feet are disturbingly hidden from view.

One of the very few elements in the painting that recall a transversal of classical representation is the diagonal line at the lower center of the work, behind the trombone player. It represents the bannister of a stairway leading up from street level allowing access to the interior of the circus. The entryway into the unseen interior is situated, from our point of view, where two flat planes seem to abut each other on the same surface just to the right of the central figure, effectively negating the possibility of a visual “entrance” from our point of view. This diagonal, as a residual fragment of a lost schema of transversals, is redeployed as a unit of a surface, characterized not so much by flatness as by impenetrability and opacity. The surface becomes a *tabular* field with rows and columns, making impossible a punctual, or point to point, relation between spectator and image.⁹⁰ At issue here is the subversion of the essential expectations of a classical theatrical plan: the collapsing of depth and the closing off of the very site to which the sideshow beckons us. *Parade de cirque*, then, hovers ambiguously between two scopic regimes, to use Martin Jay’s phrase: between the metric and homogeneous tableau loosely synonymous with classical space, and a decentered and destabilized perceptual regime with its mobile and embodied observer.⁹¹ The evocation of a scenographic setup is a veil over the dissociated, nonhomogeneous, and additive

90. For a concise account of the significance of the point, and of punctuality, within classical epistemology, see Michel Serres, *La distribution* (Paris: Minuit, 1977), pp. 17–28. See also the discussion of punctual systems in art in Gilles Deleuze and Felix Guattari, *A Thousand Plateaus: Capitalism and Schizophrenia*, trans. Brian Massumi (Minneapolis: University of Minnesota Press, 1987), pp. 294–298. Jacques Derrida discusses Husserl’s phenomenology in terms of the punctuality of vision and the indivisibility of an experience of a pure temporal present, in *Speech and Phenomena, and Other Essays on Husserl’s Theory of Signs*, trans. David B. Allison (Evanston: Northwestern University Press, 1974), pp. 60–69. Because of the regularity with which *Parade de cirque* has been situated as an anticipation of twentieth-century flatness, I am reluctant to characterize it structurally as a “grid,” except in the terms of this problem discussed in Rosalind E. Krauss, *The Originality of the Avant-Garde and Other Modernist Myths* (Cambridge: MIT Press, 1985), pp. 13–17: “By its very abstraction, the grid conveyed one of the basic laws of knowledge—the separation of the perceptual screen from that of the “real” world. Given all of this, it is not surprising that the grid—as an emblem of the infrastructure of vision—should become an increasingly insistent and visible feature of neo-impressionist painting, as Seurat, Signac, Cross and Luce applied themselves to the lessons of physiological optics” (p. 15).

91. See the chapter on “The Crisis of the Ancien Scopic Regime,” in Martin Jay, *Downcast Eyes: The Denigration of Vision in Twentieth-Century French Thought* (Berkeley: University of California Press, 1993), and Jay, “Scopic Regimes of Modernity,” in Hal Foster, ed., *Vision and Visuality* (Seattle: Bay Press, 1988), pp. 3–28.

construction of the work.⁹² But this is not the same thing as saying that *Parade de cirque* is an anticipation of various twentieth-century manifestations of flatness in painting. Instead, one might associate this strategy with features of early cinema. Film historian Tom Gunning has argued convincingly that in spite of the frontality and unity of framing in so-called “primitive” cinema, this work has less to do with a perpetuation of theatrical traditions or the frame of the proscenium arch than it does with a countertradition of magical display and behind-the-scenes manipulation of optical appearances.⁹³ This closed-off, antiscentic space is also related to forms of popular display like shadow figures, puppet theaters, and other forms that only simulate or evoke the “cube” of a theatrical stage. In this sense the particular distribution of figures across this shallow space is a deliberate archaism, recalling less a friezelike model derived from classical antiquity than the processional organization of medieval religious theater and mystery plays.⁹⁴

Given what I’ve said about the antiscentographic character of *Parade de cirque*, I want briefly to compare it with a painting which for the nineteenth century was an exemplary model of those very scenographic values, and which also has a few significant affinities with the Seurat: Leonardo’s *Last Supper*.⁹⁵ I juxtapose these two works not simply because the *Last Supper* had long seemed to be a consummate demonstration of one-point perspective but also because of specific ways in which Seurat’s work, also a technical set piece, is a relentless, even satirical negation of the assumptions underpinning Leonardo’s work.⁹⁶ Also, it would be

92. Aspects of this disjunct organization of *Parade* were sensitively noted in Robert J. Goldwater, “Some Aspects of the Development of Seurat’s Style,” *Art Bulletin* 23 (June 1941), pp. 117–130.

93. See, for example, Tom Gunning, “Primitive Cinema: A Frame Up or the Trick’s on Us,” in Thomas Elsaesser, ed., *Early Cinema: Space, Frame, Narrative* (London: BFI, 1990), pp. 95–103.

94. See George R. Kernodle, *From Art to Theatre: Form and Convention in the Renaissance* (Chicago: University of Chicago Press, 1944), pp. 13–15. Kernodle’s text is discussed and qualified in Hubert Damisch, *The Origin of Perspective*, trans. John Goodman (Cambridge: MIT Press, 1994), pp. 394–401. Damisch notes the relatively brief historical existence of “a theater whose apparatus facilitated changes of scenery and spectacular effects, all the while satisfying, in an illusionist mode, the principle of unitary organization of the scenic space.” Robert Herbert associates *Parade de cirque* with the “processional isolation” of figures in Egyptian art, in his *Neo-Impressionism* (New York: Guggenheim Museum, 1968), p. 119.

95. It should be noted that nineteenth-century knowledge of the *Last Supper* had little to do with the actual disintegrating painting in Milan; instead, most critical response to the work was based on several widely known copies of the work, such as an engraving by Raphael Morghen or prints of the 1807 “reconstruction” by Giuseppe Bossi.

96. Mary Mathews Gedo has argued that Seurat’s interest in older art was concentrated heavily on great religious works, and she makes a case that “he conceived the *Grande Jatte* as a modern icon, the secular equivalent of a great religious altarpiece. . . . The religious aspects of the composition became increasingly important as the picture progressed, and by the time Seurat applied the topmost layer of

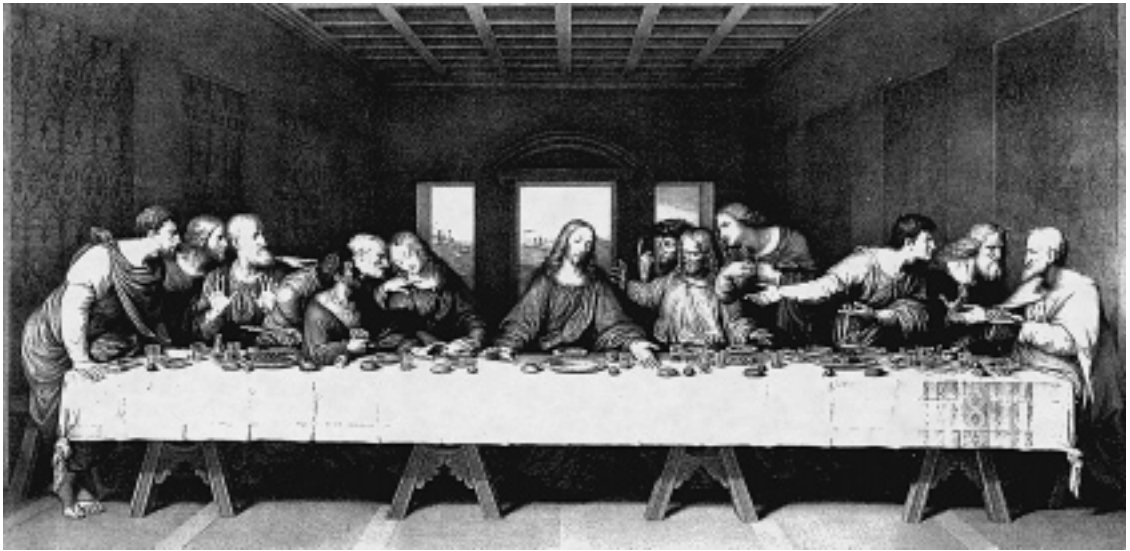

Raphael Morghen, engraving of Leonardo's *The Last Supper*, 1800.

difficult to consider more fully the relationship between art and science in the 1880s without some attention to the major revival and reorientation of interest in Leonardo beginning in that decade.⁹⁷ The point is not whether Seurat may have identified his own vocation as artist-scientist with that of Leonardo but that his own intellectual development paralleled the modern discovery of the full scope of Leonardo's interests (specifically the translations into French of his notebooks during the 1880s and a wide range of new analysis and commentary).⁹⁸ During these

Pointillist dots to the painting, each stroke had assumed the character of a ritualistic gesture imbued with a holy quality." Gedo, "The *Grande Jatte* as the Icon of a New Religion: A Psycho-Iconographic Interpretation," *Art Institute of Chicago Museum Studies* 14, no. 2 (1989), pp. 223–237.

97. *The Last Supper* is the first artwork discussed by David Sutter in his "Les phenomenes de la vision," *L'Art* (1880). This article was one of the few "sources" of his art theory that Seurat disclosed in his anxious 1890 letter to Feneon, where he is deeply concerned about the public record of his intellectual and aesthetic formation. Sutter's account of the *Last Supper* in terms of the relation between "le point de vue" and "les lignes fuyantes" (orthogonals) illustrates precisely what Seurat dismantles in *Parade de cirque*. Reiterating a comparison that had become formulaic by the mid-nineteenth century, Sutter contrasts Leonardo's painting with Veronese's more explicitly theatrical *Marriage at Cana* (1562); the latter is a work which, at least in its central section, can be affiliated with *Parade de cirque*, in that it is composed of compressed planes, such as railings and different architectural levels, whose spatial legibility is not clarified by any orthogonals. The *Last Supper* is also the primary work in the discussion of "point de vue" in Charles Blanc, *Grammaire des arts du dessin*, pp. 510–513. Blanc also uses the *Marriage at Cana* to exemplify an alternate pictorial organization, in which the unity of a single point of view and single horizon line is broken up.

98. Seurat's friend Charles Henry had been directly involved in some of the Leonardo translation and publication projects in the mid-1880s. Some influential work on Leonardo included Charles Ravaillon-

years Leonardo's cultural valence took on many conflicting forms that mirror some of the paradoxes of Seurat's own career. Certainly, Seurat would not have disagreed with Gabriel Seailles's 1888 paraphrase of Leonardo: "Art is not, as some imagine it, a mechanical or mere technical process; rather it is a mental thing, *cosa mentale*."⁹⁹

Each of these paintings, it could be said, concerns the revelation of a mystery: in one the mystery of Christian sacrifice as it coincides with a lucid apprehension of infinite extension; in the other, the making visible of the "mystery" of the disenchanted and quantitative order of capitalist exchange, and its overturning of both the homogeneity and legibility of space. As in the *Last Supper*, *Parade de cirque* has a row of thirteen figures stretching across a horizontal surface, but there is no redemptive figure in this grouping. Instead their attention, for the most part, seems casually dispersed among themselves and toward the sideshow performers. This motley crowd is witness not to holy communion but to rituals intrinsic to modernity. One of the key elements of *Parade de cirque* is the marginal vignette at the right side: we see two figures, perhaps a mother and daughter, buying tickets in order to attend the spectacle promoted by the musicians which is occurring, or about to occur, behind the backdrop that extends the length of the painting. There is a full correspondence here between the role of consumer and of attentive spectator. This relationship of exchange, this movement of abstract quantities exposes the *transactional* dimension of the work and makes the question of *value* central to its effects. The shallow little cashier's window, which is the only opening penetrating the planar screen behind the performers, is a sardonic reminder of a lost transparency, of the breakdown of the classical model of picture plane as window. One of Georg Simmel's early insights was how the uses of money within modernity transformed the social character of exchange from something interpersonal to an anonymous transaction, and to exchange at a

Mollien, "Les écrits de Leonard de Vinci," *Gazette des Beaux-Arts* 23 (1881), pp. 225ff, 331ff, 514ff; H. De Geymüller, "Derniers travaux sur Leonard de Vinci," *Gazette des Beaux-Arts* 34 (1886), pp. 143–164; Gabriel Seailles, *Leonard de Vinci: L'artiste et savant. Essai de biographie psychologique* (Paris: Perrin, 1892). One of the conclusions made by Ravaisson-Mollien concerns the centrality of geometrical proportions in Leonardo's thought: "He says, in effect, that proportion can be discovered not only in numbers and measurements but also in sounds, weights, time, locations, and in all kinds of forces" (p. 237). Earlier Hippolyte Taine, a close friend of Seurat's teacher Henri Lehmann, wrote on Leonardo with particular attention to the element of androgyny in his artwork, in "Leonard de Vinci" (1865), in Taine, *Derniers essais de critique et d'histoire* (Paris: Hachette, 1894), pp. 340–374. On the general cultural impact of Leonardo in late nineteenth-century France, see A. Richard Turner, *Inventing Leonardo* (New York: Knopf, 1992), pp. 132–149.

99. Gabriel Seailles, "Peintres contemporains: Puvis de Chavannes," *Revue bleue: revue politique et littéraire* 6 (February 11, 1888), p. 183.



Seurat, Parade de cirque, detail.

distance.¹⁰⁰ Seurat's depiction of the ticket seller's window becomes a concentrated image of the accumulated social experience of separation, of depersonalized exchange. Finally, that act of exchange is what supplants the miracle of transubstantiation in Leonardo's work: here it is the convertibility of any object, experience, or perception into a form of universal equivalence.¹⁰¹

100. Georg Simmel, *The Philosophy of Money* (1900), trans. Tom Bottomore and David Frisby (London: Routledge, 1978), pp. 297–303, 460–461. “The a priori equivalence of prices for all commodities will eliminate the numerous deliberations and examinations of the buyer, the numerous efforts and elucidations of the seller, so that the economic transaction will very quickly and indifferently pass through its personal channels” (p. 461). It should be remembered that Simmel began work on this project in the late 1880s, first publishing his paper “On the Psychology of Money” in 1889.

101. As Jean-Joseph Goux has shown, capitalism is a system in which “the libidinal, the intersubjective, and the semantic are completely divorced from economic relations, which are henceforth *uncovered* as such.” He describes a general “disaffection” of value, a draining away of the personalized and signifying dimensions of exchange and the emergence of a fully autonomous economic sector that resists seman-

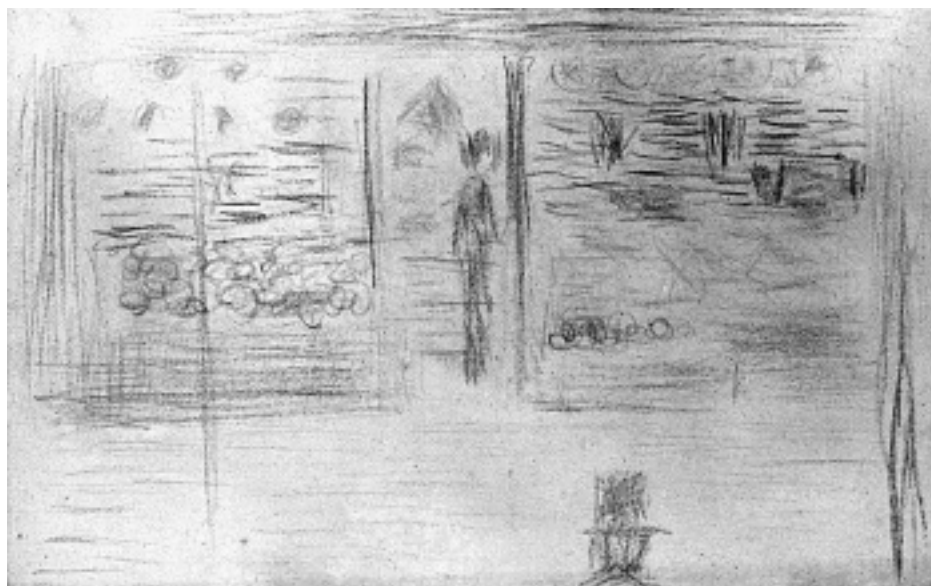

Georges Seurat, *A Shop and Two Figures*, c. 1882.

Five years or so earlier, Seurat had worked on a related image in which we also see the implied transparency of an apparent attraction, of a window, closed off to become an opaque luminous screen. This remarkable color drawing from around 1882, *A Shop and Two Figures*, has a general structural similarity to *Parade de cirque*. It too is “scenic” in that it is determined by the position of an observer, the head of a man, occupying the bottom of the frame like a single representative of the spectators in the later painting. He too is facing a plane composed of rectangular elements, which here are the facade and glass windows of a store. But Seurat withholds any legible information about the objects offered up for sale, and instead diagrams the formal conditions of exhibition and attraction in which the specific identity of the commodity form is irrelevant. Devoid of orthogonals, its symmetrical format is broken by the inclusion of a vertical on the left, much like the effect of the tree in *Parade de cirque*. I note this drawing as support for the idea that *Parade de cirque* is another (though obviously fully developed) meditation on the emptiness of a modern relation of display and consumption. *Parade de cirque* also represents the explicitly economic milieu of *A Shop and Two Figures*, the

tic or affective investment. Goux, *Symbolic Economies after Marx and Freud*, trans. Jennifer Gage (Ithaca: Cornell University Press, 1980), pp. 125–129.

ubiquity of the subjective experience of “shopping” and its construction as spectacle.¹⁰² The distribution of color in this drawing is especially interesting: the two figures, the window frames, and the sketchy indications of street and surrounding area are uniformly done in dark violet. The content of the shop windows, however, are fields of vivid color contrasts—of blue-yellow, of orange-blue—and touches of pure yellow. A stark opposition is thus set up between the monochromatic world of the street and spectators and the flickering multicolored screen of the windows themselves as bright zones of attraction.

If at the center of the *Last Supper* the head of Jesus is aligned with the vanishing point and central window opening onto infinite celestial space, what occupies the related area of *Parade de cirque* may be equally significant. This is the large sign indicating the cost of admission, at two different rates, in centimes, but it is partially obstructed by the central figure so that all we see of it are two zeros (and a fragment of the digit next to the upper zero, perhaps a “3” indicating 30 centimes). In its cancellation of any transcendent resonances, it is what might be called one of the vanishing points of modernity—the price tag exhibited in all its abstraction, the price tag as the draining away of the illusion of reference or stability.¹⁰³ It indicates a new limit of rationalization and disenchantment in art practice. The immobile appearance of the image is set off against the very process of circulation and convertibility that is represented. At the same time the simulation inherent in the literal spectacle is inseparable from the “semblance” which is the price tag. For Marx, the price is “the symbol of itself,” it is “only fleeting, a

102. It might be valuable, however, to consider the relation between the two figures: the figure at the lower right, clearly male, observes another of uncertain gender standing just beyond the threshold of the doorway to the shop. This arrangement has some of the structure of an early detective story: the covert surveillance of one individual by another. I mention this feature to associate it with such a narrative: Edgar Allan Poe’s “The Man of the Crowd,” in which the narrator trails a particular stranger “whithersoever he should go” and “so as not to attract his attention.” Although the tale was written around 1840, stores are a crucial part of this stranger’s itinerary: “At no moment did he see that I watched him. He entered shop after shop, priced nothing, spoke no word, and looked at all the objects with a vacant stare.” It is precisely that kind of vacant stare which becomes part of Seurat’s vision of the store windows here, and subsequently in *Parade de cirque*. Beyond this specific content, Poe’s brief text, in its paradigmatic articulation of modern loneliness, also corresponds to the proto-sociology informing Seurat’s oscillation between images of isolated figures and social collectivities. The narrator of Poe’s tale recounts how his “electrified” intellect “first took an abstract and generalizing turn. I looked at the passengers in masses, and thought of them in aggregate relations. Soon, however, I descended to details, and regarded with minute interest the innumerable varieties of figure, dress, air, gait, visage, and expression of countenance.” Edgar Allan Poe, *Poetry and Tales* (New York: Library of America, 1984), pp. 388–396. Charles Henry indicated the way in which Poe might well have been of interest to Seurat, as a poet who celebrated the importance of science, in his “Introduction a une esthetique scientifique,” *Revue contemporaine* (1885), p. 444.

103. A vanishing point in a perspectival construction has no necessary connection with the mathematical center of a painting.

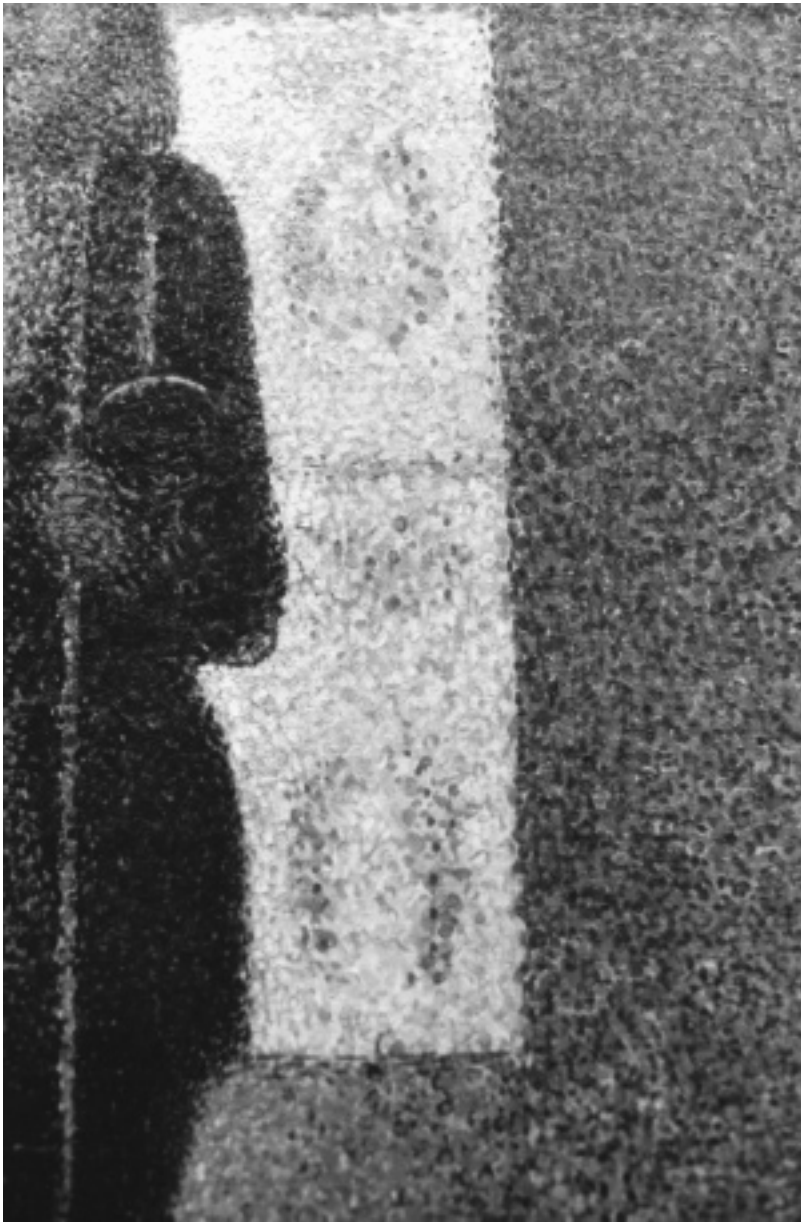

Seurat, *Parade de cirque*, detail.

reality destined constantly to disappear, to be suspended, not to count as a definitive realization but always only as an intermediate, mediating realization. . . . It exists, therefore, in so far as it remains in this constant movement . . . its reality is not that it is the price but that it *represents* it, is its representative—the materially present representative of the price, thus of itself, and as such, of the exchange value of commodities.”¹⁰⁴ The literal ambivalence of the price tag here in *Parade de cirque* becomes a key to a general problematizing of symbolic practices in the painting as a whole.¹⁰⁵ Whether it is color or money, Seurat situates his own practice within a regime of signs that are symbols of value rather than possessed of any intrinsic value themselves. It is within this problematic that his work is crucial to any consideration of the question of “symbolism” in late nineteenth-century culture.

In addition to being a price tag (in which the two digits hover as reminders of the stratified class character of consumption), it is also, and perhaps more importantly, a calculated positioning of the mathematical sign of zero at the core of the work. This placard declaring the price of admission (an admission which, as I have shown, is impossible visually) becomes a sign about a sign, a sign that assumes a crucial importance in the painting. Brian Rotman has indicated how it is the “double aspect of zero, as a sign inside the number system and as a meta-sign, a sign about signs outside it, that has allowed zero to serve as the site of an ambiguity between an empty character (whose covert mysterious quality survives in the connection between ‘ciphers’ and secret codes), and a character for emptiness, a symbol that signifies nothing.”¹⁰⁶ In the context of my reading of the work, it is difficult to avoid its essentially nihilistic force, its announcement of the vacancy and absence that suffuse the entire painting. Rotman argues convincingly that there is an isomorphism between the vanishing point in visual representation, the use of zero in computation, and abstract money in economic exchange as these forms emerge in the Renaissance. However, his account does not address Erwin

104. Karl Marx, *Grundrisse*, trans. Martin Nicolaus (New York: Random House, 1973), pp. 211–212.

105. Seurat’s preoccupation with the idea of the price is evident in his rationalization of the cost of his own artworks. See Schapiro, “Seurat and ‘La Grande Jatte,’” p. 16.

106. Brian Rotman, *Signifying Nothing: The Semiotics of Zero* (New York: St. Martin’s Press, 1987). See Sergei Eisenstein’s remarkable analysis of another painting from the late 1880s in which the presence of a “zero point” is the decisive element in a composition structured in terms of the golden section. Eisenstein insists that in Vasily Surikov’s *The Exile of the Boyarina Morozova* (1887) the viewer’s attention is deliberately directed to a point “that is the most important” but which is “unportrayable plastically.” Sergei Eisenstein, *Nonindifferent Nature*, trans. Herbert Marshall (Cambridge: Cambridge University Press, 1987), pp. 23–26. Surikov (1848–1916) was, like Seurat, a late nineteenth-century painter committed to exploring “the mathematics of painting.”

Panofsky's insistence that the vanishing point was a figuration of the coincidence of the transcendent and the empirical. Panofsky describes "true central perspective with its infinitely extended space centered in an arbitrarily assumed vanishing point" as resulting in "the concept of an infinity, an infinity not only prefigured in God, but indeed actually embodied in empirical reality."¹⁰⁷ *The Last Supper* is one of the clearest examples of Panofsky's claim that even though "perspective seals off religious art from the realm of the magical . . . it opens it to something entirely new: the realm of the visionary, where the miraculous becomes a direct experience of the beholder, in that the supernatural events in a sense erupt into his own, apparently natural visual space."¹⁰⁸

All of these effects of the vanishing point, of the orthogonals, of a postulated infinity are absent and nullified in *Parade de cirque* (even though they were still implicit in the loosely trapezoidal structure of *La Grande Jatte* or the quattrocento allusions in *Une baignade, Asnieres*).¹⁰⁹ If, according to many accounts, classical representation is a system of fixed relations in which subjectivity is imagined in terms of its coincidence with a quantifiable point of view, here we have a release from the binding order of that regime. But for Seurat it is always to be an ambivalent liberation, and the zeros disclose an organization of signs and values in which identity and reference are marginalized in favor of exchangeability and flux, an organization that also governs the molecular strata of the painting's composition.¹¹⁰ As Levi-Strauss and others have noted, zero effectively functions as a "floating signifier" even as it affirms the existence of the structure in which effectively

107. Erwin Panofsky, *Perspective as Symbolic Form* (1924), trans. Christopher S. Wood (New York: Zone Books, 1991), p. 65. This book also contains a detailed discussion of the Vitruvian account of scenography.

108. Panofsky, *Perspective as Symbolic Form*, p. 72. "Perspective, in transforming the *ousia* (reality) into *pbainomenon* (appearance), seems to reduce the divine to a mere subject matter for human consciousness; but for that very reason, conversely, it expands human consciousness into a vessel for the divine."

109. In Leo Steinberg's brilliant analysis of *The Last Supper*, "the trapezoid—the form produced wherever orthogonals meet a transversal—is the single most characteristic figure in fifteenth-century painting. For the Quattrocento painter building one-point perspective with rectilinear elements, it is the ineluctable modality of the visible. In the *Cenacolo* it is the form-giving cause, the visual principle that reconciles the phenomenal world with the manifestation of God." Steinberg, "Leonardo's Last Supper," *Art Quarterly* 36, no. 4 (1973), pp. 297–410.

110. Friedrich Engels, writing in the late 1870s, elaborated the usefulness of zero within the ongoing development of the sciences: "Zero, because it is the negation of any definite quantity, is not therefore devoid of content. On the contrary, zero has a very definite content. As the border line between all positive and negative magnitudes, as the sole really neutral number, which can be neither positive nor negative, it is not only a very definite number, but also is itself more important than all other numbers marked off from it. In fact, zero is richer in content than any other number." Engels, *Dialectics of Nature*, trans. Clemens Dutt (New York: International Publishers, 1940), p. 251.

“meaningless” signs circulate. In *Parade de cirque* this structure then still bears within it a locus for a transcendental signifier, but that place can now be occupied by a substitutional chain of empty signs. According to Kojin Karatani, “No matter how radical this reversal may be, it must be noted that the floating signifier, or zero sign, guarantees the structurality of structure and, thus, exists merely as a proxy for God or the transcendental ego.”¹¹¹ There is a reciprocal relationship between Seurat’s “dot” or atomized mark which in itself carries the meaning of sheer presence and nothing else, and these central graphic signs—loops, rings, circles—that depict absence through the division of space into an inside and outside.¹¹² Seurat notably refrains from displaying a single zero, which might have suggested a more primal image of nothingness, like the mystical letter of the Kabbalah, the egg, the Uroboros of other traditions. Instead, the doubling or repetition of the zero demystifies and disperses it within a logic of mechanical repeatability, like two successive frames of film or like the row of musicians at the left, arrayed as if indistinguishable workers on an assembly line. Within a system in which even nothingness can be duplicated, these signs cannot be the figuration of a point of origin. Also, it might be possible to think of the two zeros as potential components of the mathematical symbol for infinity (about which Charles Henry had already written) of two adjacent loops, a symbol here dismantled and dispersed into traces of its negation and loss, abandoning what Derrida calls “the positive plenitude of classical infinity.”¹¹³

The thematic of absence and exchange signaled by the zeros is inseparable from the overall content of the image: it is the evocation of a spectacle to which we are emphatically denied visual access but to which we are nonetheless attracted and enticed. Even the virtuality and abstraction of a vanishing point are negated.¹¹⁴ The painting is another disclosure of the irremediable vacancy that Mallarmé noted at the London exposition, and which is finally the primary object of

111. Kojin Karatani, *Architecture as Metaphor: Language, Number, Money*, trans. Sabu Kohso (Cambridge: MIT Press, 1995), p. 43. See also Claude Lévi-Strauss, “L’introduction à l’œuvre de Marcel Mauss,” in Marcel Mauss, *Sociologie et anthropologie* (Paris: Presses universitaires de France, 1950), pp. ix–lii; and Jacques Derrida, “Structure, Sign and Play in the Discourse of the Human Sciences,” in *Writing and Difference*, trans. Alan Bass (Chicago: University of Chicago Press, 1978), pp. 278–294.

112. Charles Henry wrote a two-part article in which he discussed the historical origins of various mathematical signs, including zero and the sign for infinity, in “Sur l’origine de quelques notations mathématiques,” *Revue archéologique* 37 (1878), pp. 324–333; 38 (1879), pp. 1–10.

113. See Jacques Derrida, “Violence and Metaphysics,” in *Writing and Difference*, pp. 112–113.

114. It should be remembered that Marshall McLuhan characterized Seurat’s work as a crucial historical threshold that “reversed traditional perspective by making the viewer the vanishing point,” in *Through the Vanishing Point: Space in Poetry and Painting* (New York: Harper and Row, 1968), pp. 24–25.

spectacular attentiveness. If the *Last Supper* symbolically opens onto a noumenal world, *Parade de cirque* obliterates that opening and replaces it with a facade of appearance and semblance. *Parade de cirque*, first exhibited while Nietzsche wrote his *Twilight of the Idols*, is also, on its own terms, a meditation on the evaporation of a true world, on its unknowability, its unattainability, its undemonstrability. Perhaps most significantly, *Parade de cirque* insists that the foreclosure of that true world is inseparable from the fragility and insubstantiality of the apparent world.¹¹⁵ At the same time it is a laying bare of the opacity and deception implicit in classical representation, of the obsolescence of the legible position presumably assigned to the observer by that system.¹¹⁶

Of course it is not just the zeros that are crucial to the operation of the work. The enigma of the central figure is important in this respect. For over a hundred years the model or source for this ominous trombone player has been consistently identified by art historians, critics, and others as premodern—whether Egyptian priest, medieval magus, Babylonian snake charmer, headsman or executioner, or other type of esoteric, cultic initiate or magician.¹¹⁷ In whatever imprecise way, then, this iconic and ambiguous figure has stood for a residue of an earlier social world in which the sacred, the occult, and artmaking were much more closely tied together but that survives merely as debasement or parody, the figure now a kind of clown. But the suggestion of magician also becomes emblematic of a modernized order of spectacle, of the mass management of attentiveness and its commodification. It is the rationalized magic of a technology of attraction that conceals its

115. See Nietzsche, *The Twilight of the Idols* (1889), in *The Twilight of the Idols; and, The Anti-Christ*, trans. R. J. Hollingdale (Harmondsworth: Penguin, 1968), pp. 40–41.

116. See Andre Green, “The Psycho-analytic Reading of Tragedy,” in Timothy Murray, ed., *Mimesis, Masochism, and Mime: The Politics of Theatricality in Contemporary French Thought* (Ann Arbor: University of Michigan Press, 1997), p. 138: “The theatrical space is bounded by the enclosure formed as a result of the double reversal created by the exchanges that unfold between the spectator and the spectacle, on either side of the stage. We may try to eliminate this edge; it is only reconstituted elsewhere. This is the invisible frontier where the spectator’s gaze meets a barrier that stops it and sends it back—the first reversal—to the onlooker, that is, to himself as source of the gaze.”

117. For example, the figure is likened to a headsman in John Russell, *Seurat* (New York: Praeger, 1965), p. 218; Richard Thompson suggests similarities with Rembrandt’s *Christ before Pilate* and its associations with impending execution and sacrifice in his *Seurat* (Oxford: Phaidon, 1985), p. 155; Françoise Cachin describes the scene as “a solemn, quasi-sacerdotal ritual . . . a mysterious ceremony of initiation,” in *Seurat: Le reve de l’art-science* (Paris: Gallimard, 1991), p. 96; Robert Herbert proposes both “magician” and, arguing for Egyptian sources, an Osiris figure, with its hints of the underworld and sacrifice, in “‘Parade de cirque’ de Seurat et l’esthétique scientifique de Charles Henry,” p. 18. For a literary background to some of these iconographic possibilities, see E. M. Butler, *The Myth of the Magus* (Cambridge: Cambridge University Press, 1948). The figure of “le Mage,” as the authentic artist who creates “harmonie” out of “la vraie Science,” is associated with Leonardo, Beethoven, and Wagner in Teodor de Wyzewa, “Le pessimisme de Richard Wagner,” *Revue wagnerienne* 6 (July 8, 1885), pp. 167–170.



Seurat, Parade de cirque, detail.

own synthetic construction and its fleeting insubstantiality. In this sense the central figure stands as a paradoxical overlapping of Weber's opposition of charismatic and bureaucratic domination. It suggests the way in which the prophetic or oracular individual, and the "unstable" domination implied by it, becomes assimilated into the administered and rationalized order of a money economy. Weber in fact uses the phrase "the castration of charisma" to describe its inevitable decline and "routinization" within the rise of permanent institutional structures.¹¹⁸ In a more general way, the painting elides the effects of religion and spectacle in that both operate through processes of isolation and symbolization. The "priestly" status of the trombone player (within the hierarchical and pseudo-scenic structure of the work) implies a pathos and metaphysics of *distance*, while at the same time the essential separation between reality and appearance, on which a priestly order depended, is dismantled by the painting itself. Yet it is impossible to detach the unsettling effects of this sideshow from its liminal position—between the activation of a broken collective memory on one hand and the imposition of modern oblivion on the other.

"Routinization" is especially appropriate for this bleak image of a collective experience of music, making it difficult to believe that the notion of harmony here for Seurat was anything but ironic.¹¹⁹ He is presenting music as a socialized activity, indicating the superficial appearance of a collective reception, now drained of any socially redemptive or utopian possibilities, and the immediacy of an audience of privatized and isolated consumers. The four musicians at the left are like the degraded and mocking remnants of what once might have been the living Dionysian reality of the antique chorus. Their grim monotony is equally remote from an earlier nineteenth-century ideal of musical performer as a quasi-sexualized virtuoso. Now fragmented into individual producers, they labor dronelike within a larger ensemble, with the boredom of a third-rate military band.¹²⁰ According to Jacques

118. Max Weber, *Max Weber: Selections in Translation*, ed. W. G. Runciman, trans. E. Matthews (Cambridge: Cambridge University Press, 1978), pp. 247–248. For a discussion of Weber's account of charismatic domination, and his distinctions between magical, religious, and rational charisma, see Wolfgang Schluchter, *The Rise of Western Rationalism: Max Weber's Developmental History* (Berkeley: University of California Press, 1981), pp. 118–128.

119. See the discussion of painterly representations of musical performance in the nineteenth century in Richard Leppert, *The Sight of Sound: Music, Representation, and the History of the Body* (Berkeley: University of California Press, 1993). One of the problems Leppert pursues is how "vision focuses on the physicality of music making itself (the sight of the body's labor to produce sound). . . . Music, despite its phenomenological sonoric ethereality, is an embodied practice, like dance and theater" (pp. xx–xxi).

120. The modern era of the trombone begins around 1800, when it was rediscovered not only for use in the orchestra but more specifically for music associated with public ceremony and especially as a

Attali, the organization of music in Europe shifted significantly after 1850 as it became more aligned with the rationalizing imperatives of industrial production. “The musicians—who are anonymous and hierarchically ranked and, in general, salaried productive workers—execute an external algorithm, a ‘score’ [*partition*] which does what its name implies: it allocates their parts. Some among them have a certain degree of freedom, a certain number of escape routes from anonymity. But they are the image of programmed labor in our society. Each of them produces only a part of the whole having no value in itself.”¹²¹ Of course this idea of the isolated part drained of value or sense corresponds to the empty combinatorial logic of the displayed zeros, and also to the operation of Seurat’s chromatics in which the individual mark or unit of color has no intrinsic meaning.

But clearly the effects of the painting are inseparable from its historical sedimentation, that it preserves the resonance of scenic space even as it annihilates it, that it retains a suggestion of rite and collective participation even as it discloses their vacancy, that it evokes the harmonic relationships and premodern mysteries implicit in music and in geometrical forms even as they are collapsed into modern abstraction and the image of a fully administered world.¹²² In a larger sense, the painting suggests the ambivalent fate of the category of the sacred within industrial society: according to Georges Bataille, “it is in just such a society (or any society with a tendency to reduce itself to homogeneity) that the sacred elements generally acquire a subversive value . . . within an aggregate that is no longer founded on social bonding but on personal interest it tends, on the contrary, toward its destruction.”¹²³ Already in the 1870s Gustav Fechner had attempted to rationalize the aesthetic appeal of the golden section by demonstrating that its ratios were merely those statistically determined to appeal to a majority of spectators.¹²⁴ More immedi-

part of the fast-growing phenomenon of the military band, according to Anthony Baines, ed., *The Oxford Companion to Musical Instruments* (Oxford: Oxford University Press, 1992), pp. 342–345.

121. Jacques Attali, *Noise: The Political Economy of Music*, trans. Brian Massumi (Minneapolis: University of Minnesota Press, 1985), p. 66.

122. Several art historians and critics have attempted to demonstrate that the proportions of the golden section are embedded throughout *Parade*. See, for example, the well-known and now generally discredited diagram in Henri Dorra, “The Evolution of Seurat’s Style,” in Henri Dorra and John Rewald, *Seurat* (Paris: Les Beaux-Arts, 1959), pp. lxxxix–cvii.

123. Georges Bataille, “The Moral Meaning of Sociology,” in *The Absence of Myth*, trans. Michael Richardson (London: Verso, 1994), p. 108.

124. Gustav Fechner, *Vorschule der Aesthetik*, vol. 1 (Leipzig: Breitkopf und Hartel, 1876), pp. 184–202. For a withering assessment of Fechner’s text and a general attack on positivist models of “physiological” aesthetics, see Benedetto Croce, *Aesthetic* (1901), trans. Douglas Ainslie (London: Peter Owen, 1953), pp. 390–398.

ately relevant to Seurat were Charles Henry's claims that the proportions of the golden section had particular dynamogenic properties.¹²⁵ Yet if we can speak of Seurat's "Pythagoreanism" (an enduring art historical commonplace about this artist), it is a deeply ambivalent characterization. The particular figuration of measurement, quantities, and ratios in *Parade de cirque* diagrams a crisis of value, a crisis that corresponds to Nietzsche's contemporary diagnosis of a devaluation of life and the world. If Seurat did in fact remark in 1888 to Gustave Kahn that he sought to make a modern-day equivalent of Phidias's Panathenaic procession, it makes sense more in terms of negation and inversion, a bitter rebuttal of the kind of neo-antique work that Puvis de Chavannes and others had been doing. However, the question of Pythagoreanism is also a potentially rich avenue into a painting that is centrally linked to both music and mathematics.¹²⁶ Charles Henry was one of many in Seurat's circle who were preoccupied with the contemporary relevance and value of Pythagorean thought.¹²⁷ Certainly, one of Seurat's most provocative declarations about his own work (from the 1890 letter to Maurice Beaubourg) has unmistakable Pythagorean implications: "Art is Harmony. Harmony is the analogy between opposites."¹²⁸

125. Charles Henry, *Cercle chromatique, présentant tous les compléments et toutes les harmonies de couleurs* . . . (Paris: C. Verdin, 1888), p. 52.

126. A monumental source for these ideas in Seurat's time was Anthelme Edouard Chaignet, *Pythagore et la philosophie pythagoricienne*, 2 vols. (Paris: Didier, 1873). Seurat's friend Charles Henry frequently buttressed his own work with references to Pythagoras. See, for example, "Le contraste, le rythme, la mesure." Henry conceived of his lifework as the groundwork and preparation for "the renewal, in the near future, of Ontology, utilizing the immense progress of science, and for the instituting of Pythagoreanism and the Kabbala on scientific foundations," according to Francis Warrain, *L'oeuvre psychobiologique de Charles Henry* (Paris: Hermann, 1938), p. 491.

127. It's possible that Seurat and Henry were aware of at least superficial similarities between contemporary theories of dynamogeny and elements within Pythagorean tradition: "Even more immediately evident is the undeniable influence of Number on our psychic state through the medium of music, depending as it does on numerical proportion. Certain musical proportions express a sense of cheerfulness; others, such as the minor third, possess a bittersweet quality that can make us sad. The fact that number can influence a person's emotional state is indeed mysterious and points toward a dimension of qualitative Number which transcends the merely quantitative." K. S. Guthrie, *The Pythagorean Sourcebook*, ed. David Fideler (Grand Rapids, Mich.: Phanes Press, 1987), p. 34.

128. Seurat, letter to Beaubourg, in Broude, ed., *Seurat in Perspective*, p. 18. The key source for the Pythagorean doctrine of opposites was Aristotle's *Metaphysics*. See *The Complete Works of Aristotle*, vol. 2, ed. Jonathan Barnes (Princeton: Princeton University Press, 1984), pp. 1559–1562. Another text, widely referred to in the 1880s, was the account by the fourth-century A.D. Neoplatonic mystic Iamblichus. This work certainly suggested the notion of Pythagoreanism as a social project of reconciliation through the use of aesthetic form: "He thought that the training of people begins with the senses, when we see beautiful shapes and forms and hear beautiful rhythms and melodies. So the first stage of his system of education was music: songs and rhythms from which came healing of human temperments and passions." Iamblichus, *On the Pythagorean Life*, trans. Gillian Clark (Liverpool: Liverpool University Press, 1989), p. 26.

It might be possible to specify the painting's evocation of disenchantment, of the loss of transcendent signifiers, as part of a deliberate negation or degradation of Pythagorean values. *Harmonia* and number, which Aristotle identified as the constituents of the Pythagorean cosmos, and both central to Seurat's thought, are deployed in a world of mere empirical relations, cut off from the infinite (loss of the vanishing point) and from the light of either sun or moon (gaslight illuminates the scene).¹²⁹ If, in the Pythagorean tradition, music had healing powers and was an instrument for enhancing social cohesion, music in *Parade de cirque* seems at once anesthetic and an element of modern anomie.¹³⁰ At the same time, any speculation about Seurat's political leanings, about his "anarchism," could only be enriched by one of the key contemporary characterizations of Pythagorean social doctrine, what the Platonic tradition had referred to as "the peculiar mode of life" of the Pythagoreans. Quite simply, in the context of post-1871 France, this is an anxious euphemism for primitive communism, for various accounts that his followers all "held their goods in common."¹³¹

But most significant for this possible reading is the central trombone player and the precise location of the musical instrument. The lefthand tube of the trombone is the central vertical axis of the painting, that is, it mathematically bisects the rectangular image, and thus reverberates with the accumulated historical significance of this pictorial partitioning.¹³² At this pivotal site in the work, then, is a

129. Philosopher Charles Renouvier had insisted that the most relevant element of Pythagoreanism for modern thought was its opposition of "number" and "the infinite," and he asserted that "for the Pythagoreans, the infinite was the void [le neant] of knowledge," the limitless and undetermined against which number was both rational limit and determination. Renouvier, *Essais de critique generale. Premier essai* (Paris: Ladrangue, 1854), p. 381. But by conflating zero (which has no limiting or determinate function) with site of the vanishing point, Seurat operates outside the moral dualism at the foundation of this system.

130. It would be misleading simply to equate Pythagoreanism with premodern, mystical values when in fact some of the great "disenchanters" at the origins of modern Western science are deeply Pythagorean in their outlook. "Nevertheless, the major thesis of the Pythagoreans, namely, that nature should be interpreted in terms of number and number relations, that number is the essence of reality, dominates modern science. The Pythagorean thesis was revived and refined in the work of Copernicus, Kepler, Galileo, Newton and their successors, and is represented today by the thesis that nature must be studied quantitatively." Morris Kline, *Mathematics in Western Culture* (Oxford: Oxford University Press, 1953), p. 78. Michael Polanyi insists that Descartes's universal mathematics is a manifestation of Pythagoreanism: "his hope of establishing scientific theories by the apprehension of clear and distinct ideas, which as such were necessarily true." *Personal Knowledge* (Chicago: University of Chicago Press, 1958), p. 8.

131. Charles S. Peirce in 1892 insists on the "undeniable political character" of the original Pythagorean community and refers to Pythagoras as "one of the greatest names in the history of science" in his Lowell Lectures on the History of Science, in *Charles Sanders Peirce: Selected Writings*, ed. Philip P. Wiener (New York: Dover, 1958), pp. 239–246.

132. For an exemplary discussion of the theological deployment of a central vertical axis, see David Rosand, "Raphael and the Pictorial Generation of Meaning," *Source: Notes in the History of Art* 5, no. 1 (Fall 1985), pp. 38–43.

line that links the mouth of the figure with its crotch and which designates a device fundamentally dependent on breathing. In Pythagorean thought, breath was a primal cosmogonic principle: respiration with its binary rhythm of inhaling and exhaling was the original generative force, like the literal sexual act, the mutual interaction of contraries, the union of the limited and the unlimited. Thus this unsettling figure can bear a large but not unwarranted interpretive burden. Its location has a mathematically determined identity, making it a figure for the congruence of music, number, and harmony. In its literal operation the trombone stands for an overlapping of the cosmic procreative powers of numbers (as musical relations), breath, and sexual intercourse.¹³³ The question, though, remains: are these elements deployed parodically, ironically, or despairingly?

It is also important to note the uncertain gender of the trombone player: the strange mix and blurring of conventional male and female attributes, the ambiguous articulation of thighs, legs, and hips and the hauntingly nebulous features of its face, of sockets with no eyes.¹³⁴ Its imperious centrality seems strangely at odds with its attenuated, even spindly silhouette. The primordial Orphic intuition of the double but unified nature of human existence (which Pythagoreanism transformed into male and female numbers) is expressed here as a single sexually ambiguous figure.¹³⁵ The apparent androgyny of this figure is all the more striking given the highly legible and socially coded gender identity of almost every other individual in the painting. This disquieting object of fascination in the center of the painting at the lost vanishing point is evidence of the work's ambivalence: of both its destabilizing sexual confusion and its will to a reunification of what has been divided

133. On the problem of generation and procreation in Pythagorean thought, see Jonathan Barnes, *The Presocratic Philosophers*, vol. 2 (London: Routledge, 1979), pp. 76–81.

134. Sideshows, such as the one depicted in *Parade de cirque*, sometimes featured hermaphroditic performers. See Paul Smith, *Seurat and the Avant-Garde* (New Haven: Yale University Press, 1997), p. 191, n. 2, for reference to contemporary accounts of the *foires* that Seurat frequented, which describe the display of “des monstres qui sont a la fois homme, femme [of freaks who are both male and female].”

135. On the persistence of Pythagorean dualities in Western philosophy, see Michele LeDoeuff, “Women and Philosophy,” in Toril Moi, ed., *French Feminist Thought* (Oxford: Blackwell, 1987), p. 196. On the notion of an “original” bisexuality, see Judith Butler, *Gender Trouble: Feminism and the Subversion of Identity* (New York: Routledge, 1990), p. 54: “From the start, however, the binary restriction on sexuality shows clearly that culture in no way postdates the bisexuality that it purports to repress: It constitutes the matrix of intelligibility through which primary bisexuality becomes thinkable. The ‘bisexuality’ that is posited as a psychic foundation and is said to be repressed at a later date is a discursive production that claims to be prior to all discourse, effected through the compulsory and generative exclusionary practices of normative heterosexuality.” For a lucid insistence that the original “prototype” for the Pythagorean contraries was sexual difference, see F. M. Cornford, *From Religion to Philosophy: A Study in the Origins of Western Speculation* (1912; New York: Harper, 1957), pp. 65–72.

(color into complementaries, sex into gender, vision into figure/ground).¹³⁶ But as many writers have shown, androgyny is not an objective condition; it exists as a subjective projection onto socially constructed perceptual contents.¹³⁷ Seurat's "staging" of a historical crisis of value and representation coincides with another staging of a subjective sexual conflict. The historical archaism (through its multiple premodern allusions) of the trombone player is aligned with a parallel psychic regression in terms of a self-sufficient figure prior to separation and division, an historically sedimented figure that is also inseparable from the undifferentiated autoeroticism of early childhood (the trombone itself a concretization of overlapping phallic and oral impulses). Specifying the particular psychic material here (whether Oedipal or whatever) is probably less important than simply acknowledging the image as a phantasmic production, and providing some stronger terms for the endlessly repeated characterizations of *Parade de cirque* as dreamlike. Laplanche and Pontalis argue for a sharp distinction between fantasy and dream, that fantasy is always in part a secondary, waking elaboration of unconscious contents. Fantasy for them consists in "restoring a minimum of order and coherence to raw material handed over by the unconscious mechanism of displacement, condensation and symbolism, and in imposing on this heterogenous assortment a facade, a scenario, which give it relative coherence and continuity."¹³⁸ Relevant here for a reading of *Parade de cirque* is the idea of the facade, both as a gridlike ordering principle and as a screen concealing another unarticulable, imperceptible scene. At the same time it's possible to consider the screen itself as part of the fantasy. The operations of psychic condensation implicit in the trombone player, in

136. Jacqueline Rose's influential discussion of Freud and Leonardo is clearly relevant here: "The uncertain sexual identity muddles the plane of the image so that the spectator does not know where he or she stands in relationship to the picture. A confusion at the level of sexuality brings with it a disturbance of the visual field." Rose, *Sexuality in the Field of Vision* (London: Verso, 1986), p. 226. Richard Wagner, in discussing the androgynous significance of the title role in his *Parsifal*, referred to the figure of Christ at the center of Leonardo's *Last Supper*. Christ, he insisted, "must be entirely sexless. Leonardo, too, in the *Cena*, attempted that, depicting an almost feminine face adorned with a beard." Quoted in *Cosima Wagner's Diaries*, trans. Geoffrey Skelton (New York: Harcourt, Brace, 1977), vol. 2, pp. 498–499.

137. See, for example, Francette Pacteau, "The Impossible Referent: Representations of the Androgyne," in Victor Burgin and Cora Kaplan, eds., *Formations of Fantasy* (London: Methuen, 1986), pp. 62–84. See also the extended political and cultural survey in A. J. L. Busst, "The Image of the Androgyne in the Nineteenth Century," in Ian Fletcher, ed., *Romantic Mythologies* (London: Routledge, 1967), pp. 1–96.

138. Jean Laplanche and Jean-Bertrand Pontalis, "Fantasy and the Origins of Sexuality," *International Journal of Psychoanalysis* 49, part 1 (1968), pp. 1–18. See the assessment of recent French analyses of phantasmic constructions in Herman Rapaport, *Between the Sign and the Gaze* (Ithaca: Cornell University Press, 1994), pp. 17–90.

its multiple resonances of seduction, authority, or exhibitionism, establish another important stratum on which the image diagrams an anxious uncertainty, both social and individual, about mastery, attraction, and power.¹³⁹

Attention here is organized very differently from in Manet's *In the Conservatory*, where its simultaneous bindings and scatterings are determined by the equivocal positions and relations of the male and female couple. That dispersal and wandering of attention would have been incompatible with the perceptual logic of *Parade de cirque*. Its phantasmic qualities in large measure derive from this figuration of an undifferentiated being which in turn hierarchizes and immobilizes the entire composition. It is part of an attempt to recover a perception prior to any "divisionism." The imaginary rebinding of male and female characteristics is fully related to the quest for a luminosity of an irreducible integrity, for what Seurat called a "spectral purity," which would transcend the chromatic division and decomposition on which the work is founded.¹⁴⁰ As Victor Burgin and others have argued, fantasy operates through a stabilization or an "arrest" that domesticates the unruly movements of desire. It thus takes on hieratic and tableau-like forms, such as we see in *Parade de cirque*, which organize "the otherwise formless indeterminacies, dispersions, displacements of desire of the individual subject."¹⁴¹

What is involved here is more than the rigidity of a geometrical composition serving as a "striated" psychic constraint. Rather, we must begin to think through the interdependence of this phantasmatic figuration and Seurat's attraction to the binary scheme of dynamogeny/inhibition; to see the operation of a larger strategy

139. I believe that the *psychological effects* (though not the iconographical background) of Seurat's trombone player have important links with the figures Thomas Elsaesser identifies in silent cinema (and in Syberberg's films) as "the monstrous, uncanny redeemers, tyrants, scapegoats, sorcerer's apprentices—Dr. Caligari, Mabuse, Nosferatu, the Golem." Elsaesser associates them with the persistent romantic figure of the Double whose appearance is always greeted "with the shock of recognition followed by an equally violent disavowal of such dangerous self-knowledge. It keeps in suspension just what the relationship is between self-image and object-choice, once this becomes a question of political self-realization and manifest destiny. . . . They make visible the extent to which the ambiguous feelings of love and hate, binding the subject to his alter ego, are in fascism repressed, displaced and 'streamlined' into the cult of the charismatic leader, via what, after Freud, is 'secondary narcissism.'" Elsaesser, "Myth as the Phantasmagoria of History: Syberberg, Cinema, and Representation," *New German Critique* 24–25 (Fall–Winter 1981–1982), pp. 108–154.

140. In a June 1890 letter to Felix Fénéon, Seurat makes the declaration: "The purity of the spectral element being the keystone of my technique." Reprinted in Broude, ed., *Seurat in Perspective*, p. 16.

141. Victor Burgin, "Diderot, Barthes, Vertigo," in Burgin and Kaplan, eds., *Formations of Fantasy*, p. 98. Part of Burgin's discussion engages Roland Barthes's claim that the contents of a tableau "function in the name of a transcendence, that of the *figure*, which receives the full fetishistic load and becomes the sublime substitute of meaning." Barthes, *Image, Music, Text*, trans. Stephen Heath (New York: Hill and Wang, 1977), p. 72.

of immobilization and control. This means considering why this system is so intrinsic to *Parade de cirque*, even more so than the obviously “dynamogenic” demonstrations of *Chabut* and *Cirque*. It means understanding the importance to Seurat of a table of opposites, of dualities which, through his consummate adjustments, would at least point to the utopian possibilities of harmony. (And in the 1880s, Pythagoreanism was simply one historically exhausted name for such thinking). Seurat’s art must be evaluated less in terms of the particular “opposites” or “contraries” with which he worked (colors, lines, forces, sexes, numbers) than of the abstract functioning of such a binary logic and its relation to the formal idea of *reconciliation*, even if *Parade de cirque* simultaneously dissolves its own reconciling aspirations. Seurat’s Pythagoreanism is unavoidably complicit with the technocratic dream of a quantifiable harmony that a machinic world installs or restores.

Within the larger problem of Seurat’s disavowal of desire, what is in question is the attraction of a physiologically based theory of excitation that posed at least the possibility of a conceptual mastery of the inchoate pulsings of his own subjectivity. By intellectually grounding affect (or desire) in the mechanical economy of the nervous system, in a topographical distribution of energy, it offered a rationalization of otherwise unbearable desires that were in fact constructed elsewhere and were utterly irreducible to such a fraudulent dualistic scheme.¹⁴² Crucial in *Parade de cirque* is the congruence between the apparent reunion of opposites in the central figure and the specific formal deployment of the dynamogenic/inhibitory system. The insistent horizontals and the almost complete absence of diagonals, as well as the “neutral” chromatic organization, announce that in this work *neither* a dynamogenic (gay) nor an inhibitory (sad) effect is sought, but rather a *neutralization* of those poles. This is how the two zeros must also be read—as a quantitative expression of the affective operation of the system. Zero over zero, $\frac{0}{0}$: this stunning, stupefying quotient is finally the most powerful evocation of the inert “harmony” Seurat seeks. The nullification of the constructed categories of male and female, and the canceling out of two opposing modes of nervous energy, are parallel indications of “calmness,” the word Seurat used to designate the resolution of opposites. Calmness (or the Greek-derived *ataraxie*) is emphatically a

142. See Butler, *Gender Trouble*, p. 71: “The phantasmic nature of desire reveals the body not as its ground or cause, but as its *occasion* and its *object*. The strategy of desire is in part the transfiguration of the desiring body itself. Indeed, in order to desire at all it may be necessary to believe in an altered bodily ego which, within the gendered rules of the imaginary, might fit the requirements of a body capable of desire. This imaginary condition of desire always exceeds the physical body through or on which it works.”

reduction of tensions, a reduction even to a zero threshold, to what Freud called the “Nirvana principle,” or the cessation of all drives. The semantic and economic nihilism of these ciphers is adjacent to another perhaps more powerful operation of dissolution, which Freud so consequentially described: “The dominating tendency of mental life, and perhaps of nervous life in general, is the effort to reduce, to keep constant or to remove internal tension due to stimuli . . . and our recognition of that fact is one of our strongest reasons for believing in the existence of death instincts.”¹⁴³ To invoke this layer of fatality in *Parade de cirque* is certainly not to anchor the significance of the work in the abyssal resonances of Freud’s problematic concept, but rather to suggest the disturbing multivalence of the “homeostasis” that Seurat establishes.¹⁴⁴ The ideal of a diminution of tension, of a “constancy” of affect operates here both as a regression to a preindividuated unity and as the utopian projection into the future of a social harmony in which division and separation have been overcome, even if it is the quiescent harmony of a neopolis. The implicit effect of this “theater” of equilibrium is the erasure of both individual and historical temporality. It is a dream that begins, at least in its nineteenth-century guise, with Schopenhauer—the dream of an attention absolved of the play of difference, of flux—of a perception that becomes a suspension of will, a submission to the frozen phantasmic logic of unification. As Jean-Jacques Nattiez has concluded, it is a question of the illusion that “humanity could reach a stable point at which contradictions no longer exist and time can be arrested. . . . It is for this reason that androgyny and death so often appear together,

143. Sigmund Freud, *Beyond the Pleasure Principle*, trans. James Strachey (New York: Norton, 1961), pp. 49–50. See the remarkable critique of Freud’s text in Jean Laplanche, *Life and Death in Psychoanalysis* (Baltimore: Johns Hopkins University Press, 1976), pp. 103–124. Laplanche discusses the problematic nonidentity between a “zero principle” and a “constancy principle.” For Freud, he writes, “it is the whole of the biological domain, its history as well as its contemporary manifestations, which are infested by the immanence of a tendency to zero, working obscurely but ineluctably within” (p. 117). Some of Jean Baudrillard’s reflections from the mid-1970s are relevant to an analysis of this highly charged area of the painting: “In the capitalist mode, everyone is alone before the general equivalent. It is no coincidence that, in the same way, everyone finds themselves alone before death, since *death is general equivalence*. From this point on the obsession with death and the will to abolish death through accumulation become the fundamental motor of the rationality of political economy. Value, in particular time as value, is accumulated in the phantasm of death deferred, pending the term of a linear infinity of value.” Baudrillard, *Symbolic Exchange and Death* (1976), trans. Iain Hamilton Grant (London: Sage, 1993), p. 146; emphasis in original.

144. In her reevaluation of Freud’s *Beyond the Pleasure Principle*, Kaja Silverman provides a framework for understanding Seurat’s obsession with maintaining intellectual control over his work: “Masculinity is particularly vulnerable to the unbinding effects of the death drive because of its ideological alignment with mastery. The normative male ego is necessarily fortified against any knowledge of the void upon which it rests, and—as its insistence on an unimpaired bodily ‘envelope’ would suggest—fiercely protective of its coherence. . . . Disintegration constantly halts the subject’s attempts to effect a psychic synthesis.” Silverman, *Male Subjectivity at the Margins* (New York: Routledge, 1992), p. 61.

that social utopias end in massacres and that the structuralist utopia of an all-embracing explanation of mankind reducible to torrents of binary oppositions results in ‘nothingness.’”¹⁴⁵

But this projection of the neutralizing of drives in *Parade de cirque* hardly operates according to a seamless internal logic, any more than does the simulated *excitation* of response in *Cirque* and *Cbabut*. The central figure, the zero over zero equilibrium, the geometrical organization—all of these finally are neither static nor stabilized in *Parade de cirque*.¹⁴⁶ Just as was the case on its molecular level, there is no Gestalt capable of ordering the work. The androgynous significance of the central figure is bound up in a literally “crucial” feature of the painting: Seurat has carefully calculated his/her position to overlap with the hypothetical cruciform created by the horizontal and vertical bisection of the painting rectangle. If the shaft of the trombone coincides with the vertical midpoint, the related horizontal intersects it in the middle of the lower torso of the figure. This formal center of the painting coincides with where the phallic (though also double-sexed) trombone overlaps the anatomical position of the womb. In a more abstract sense, this highly charged site within the work is the symbolic representation of a matrix.¹⁴⁷

The idea of matrix here may seem remote from the generative cosmogony of a pre-Socratic imagination. The zeros adjacent to the figure hardly seem like signs of a mythical world egg but rather emblems of a sterility and impotence,

145. Jean-Jacques Nattiez, *Wagner Androgyne*, trans. Stewart Spencer (Princeton: Princeton University Press, 1993), p. 300.

146. Jacques Lacan insists on the “finiteness of desire” in terms of, or in spite of, the zero function: “Everyone knows that if the zero appears in the denominator, the value of the fraction no longer has meaning, but assumes by convention what mathematicians call an infinite value. In a way, this is one of the stages in the constitution of the subject. In so far as the primary signifier is non-sense, it becomes the bearer of the infinitization of the value of the subject, not open to all meanings, but abolishing them all, which is different. . . . What, in effect grounds, in the meaning and radical non-meaning of the subject, the function of freedom, is strictly speaking this signifier that kills all meanings.” Lacan, *Four Fundamental Concepts of Psycho-analysis*, p. 252. Kaja Silverman explains that for Lacan, the zero is the antithesis of a transcendental signifier. The nonmeaning of the zero “initiates the process of endless displacements and substitutions which comprise signification. . . . At the same time, it deprives the subject of any autonomy. As a consequence of the central part played by the unary signifier in the organization of the subject, the latter has no meaning of its ‘own,’ and is entirely subordinated to the field of social meaning and desire.” Silverman, *The Subject of Semiotics* (New York: Oxford University Press, 1983), pp. 172–173.

147. “The growth of the cosmos is described in the manner of the pre-Socratics, as the growth of a living being, and embryological concepts form a part of the background. The One begins to breathe and as the breath flows in, it assumes a more complicated structure.” Walter Burkert, *Lore and Science in Ancient Pythagoreanism*, trans. Edwin L. Minar (Cambridge: Harvard University Press, 1972), p. 37. See the discussion of the problem of procreation and the symbols of maternity and paternity in the political context of the French Third Republic in Julia Kristeva, *La révolution du langage poétique* (Paris: Seuil, 1974), pp. 441–508.

much like the barren tree at the left, at the core of this bleak and archaized cityscape, in a way that anticipates some themes of early twentieth-century modernism.¹⁴⁸ The slide trombone remains sexually charged but as an unproductive and mechanized autoeroticism. More importantly, however, the zeros are only the visible part of the admission price sign; when the unseen integers of the sign are considered as well, it makes up a square configuration of single numbers, with the two zeros constituting a right-hand column and the unseen numbers a left-hand column. This is a basic mathematical “matrix” (which first nominally entered modern computational practice in the 1850s), and as such stands for a quantitative conception of the entire structure of the painting. That is, a matrix is “a rectangular array of mathematical elements that can be combined to form sums and products with similar arrays having an appropriate number of rows and columns”—also “something resembling a mathematical matrix, esp. in rectangular arrangement.”¹⁴⁹ Even if all its constituent elements were zeros, it still would subsist as a functional matrix.¹⁵⁰ It’s possible, then, to see the matrix-like structure of *Parade de cirque* not simply as a grid (which modernist criticism has repeatedly suggested) but as a tabular field that is inseparable from its *enumerative* components with specifically generative possibilities. It becomes a modernized version of Durer’s magic square, but the creative capacities of that square have been remade into a purely functional significance in which the realm of the merely quantitative is never exceeded, in a modernized logic of capitalist accumulation. The matrix, then, is also what relocates Seurat’s system of drives out of both figuration and scenography into the

148. In support of Wagner, the youthful Nietzsche formulated what would be a standardized late romantic notion of a lost matrix, which is relevant to assessing Seurat’s own historical eclecticism: “And now the mythless man stands eternally hungry, surrounded by all past ages, and digs and grubs for roots, even if he has to dig for them among the remotest antiquities. The tremendous historical need of our unsatisfied modern culture, the assembling around one of countless other cultures, the consuming desire for knowledge—what does this all point to, if not to the loss of myth, the loss of the mythical home, the mythical maternal womb?” Nietzsche, *The Birth of Tragedy* (1872), trans. Walter Kaufmann (New York: Vintage, 1967), p. 136.

149. *Merriam-Webster’s Collegiate Dictionary*, 10th ed. (Springfield, Mass.: Merriam-Webster, 1993), p. 717. “The term ‘matrix’ was first assigned to a rectangular array of numbers by James Joseph Sylvestre in 1850. . . . But it was Arthur Cayley, in his paper ‘A memoir on the theory of matrices,’ in 1858, who first considered $m \times n$ matrices as single entities subject to certain laws of combination.” Howard Eves, *Elementary Matrix Theory* (New York: Dover, 1966), p. 10. See also Dirk J. Struik, *A Concise History of Mathematics*, 4th rev. ed. (New York: Dover, 1987), pp. 32–33. A matrix is described as “basically, a very simple way of organizing the numbers used to describe the various kinds of information that come to our attention every day,” in Paul Horst, *Matrix Algebra for Social Scientists* (New York: Holt, Rinehart and Winston, 1962), p. 5.

150. “A matrix in which all entries are zero is a *null matrix*, generally denoted by 0 or by the Greek letter θ (theta).” See Jan Gullberg, *Mathematics: From the Birth of Numbers* (New York: Norton, 1997), pp. 637–670.

formless, abstract flux of capitalist exchange. As both Rosalind Krauss and Jean-François Lyotard have shown, the concept of matrix, inflected by psychoanalytic discourse, designates not an intelligible organization of stable positions and values but rather processes beyond the threshold of visibility in which identities and meanings are converted into their opposites.¹⁵¹ Perhaps now it is clearer why the elimination of orthogonals is so decisive here; it establishes a powerfully modern ordering of desire and exchange in which any geometrical semblance of stability is a mask over a more powerful dispersal and circulation of affect. The “annulment” of difference figured in the columns of this matrix, rather than grounding our attention in a timeless, suspended presence, opens onto the vertigo of ceaseless differentiation. The congruence of signifier and the money-form discloses the perpetual deferral of desire, of immediacy, of presence. Perception becomes fatally caught up in the annihilating temporalities and substitutions of capitalist representation. It is, as Marx knew, a system in which appearance can only be thought as disappearance.¹⁵²

I have been attempting to indicate how the collapse of scenic space in *Parade de cirque* is inseparable both from a new organization of economic exchange and from a regressive fantasy of a primal immediacy. To achieve its aims, each of these requires an overcoming of a classical separation of subject and object, in which the two are defined in terms of stable and spatializable positions. One feature of the painting seems particularly significant in this regard: the tree at the left. I want to propose that, in addition to its obvious referential status, it could well indicate something else: a sign of a full commingling of eye and world, of an imaginary fusion of subject and object. To explore this possibility, however, requires a brief glance at scientific discourse on the eye in the mid-nineteenth century. As I have detailed elsewhere, a decisive shift occurs between 1810 and 1830 from the geometrical optics, based on the properties of light and its refraction and reflection, of the seventeenth and eighteenth centuries to a physiological optics, first outlined in the work of Goethe, Purkinje, Johannes Muller, and others.¹⁵³

151. See Rosalind E. Krauss, *The Optical Unconscious* (Cambridge: MIT Press, 1993), pp. 220–222; and Jean-François Lyotard, *Discours, figure* (Paris: Klincksieck, 1971), pp. 333–339.

152. Marx, *Grundrisse*, p. 209. See the discussion of how capitalism operates “by difference even before representation can arise,” thus producing “the dead time of difference as such,” in Gayatri Chakravorty Spivak, “Speculations on Reading Marx: After Reading Derrida,” in Derek Attridge, Geoff Bennington, and Robert Young, eds., *Post-Structuralism and the Question of History* (Cambridge: Cambridge University Press, 1987), p. 41.

153. See my *Techniques of the Observer*, pp. 67–96.

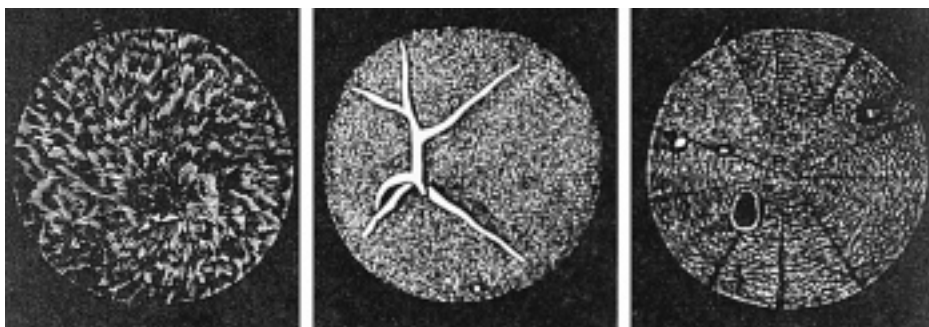

Entoptical phenomena, from Helmholtz's Physiological Optics.

The culmination of this shift was the publication between 1856 and 1866 of the three volumes of Hermann Helmholtz's *Treatise on Physiological Optics*, which not only presented Helmholtz's own extensive studies of human vision but also summarized the collective achievements of other researchers up to that time.¹⁵⁴ One of the effects of Helmholtz's widely read work was to undermine with finality any sense of the eye as a transparent organ and to put forth a comprehensive account of human vision in all its anatomical and functional complexity. The eye emerges in this text not only as a marvelous apparatus but as one with built-in aberrations, proneness to error, and inconsistencies in its processing of visual information. Helmholtz emphatically embeds the eye within the thickness and opacity of the body.

One of the ways in which Helmholtz overthrows the notion of the eye's transparency is his discussion of how under certain conditions objects *within* the eye itself become visible. These perceptions are what he and other researchers termed *entoptical* phenomena, of which he describes several categories. The most obvious type, noted incidentally by writers on vision for centuries, were the particles, specks, and other tiny aggregations suspended in the fluid medium of the vitreous humor of the eye, often called *mouches volantes*.¹⁵⁵ For William

154. The French translation of Helmholtz's work appeared in 1867 as *Optique physiologique*, trans. Emile Javal and N. Th. Klein (Paris: Victor Masson).

155. Arthur Rimbaud, in his "Les poètes de sept ans" (1871), describes such phenomena: "and he would see specks on his closed eyelids." Rimbaud, *Oeuvres complètes* (Paris: Gallimard, 1972), pp. 43–45. Another account of entoptical phenomena is in the work of the British scientist Sir Francis Galton: "When in perfect darkness, if the field of view be carefully watched, many persons will find a perpetual series of changes to be going on automatically and wastefully in it. I have much evidence of this. . . . Before I thought of carefully trying, I should have emphatically declared that my field of view in the dark was essentially of a uniform black, subject to an occasional light-purple cloudiness, and

James, entoptical phenomena are a key example of how selective attention excludes from consciousness sensations that are nonreferential, that are irrelevant to knowledge about the world. “The deepest inattention is to subjective optical sensations, strictly so called, or those which are not signs of outer objects at all.”¹⁵⁶ Helmholtz had articulated much the same pragmatic position: “We only attend with any ease and exactness to our sensations in so far as they can be utilized for the knowledge of outward things.”¹⁵⁷ To become aware of the subjective components of perception involved a conscious retraining of attention, in addition to specific techniques.

However, the most dramatic instance of an entoptical phenomenon is Helmholtz’s account of how an observer can see the blood vessels of his or her own retina. Researchers in the mid-nineteenth century discovered that the retinal blood veins were in a position to cast shadows on the rear surface of the retina, if certain luminous conditions were created. Helmholtz describes three methods of controlling the entrance of light into the eye that will render *visible to itself* its own retinal blood vessels. After detailing these instructions Helmholtz writes: “Now when the eye looks at a dark background, the latter will appear illuminated with a reddish yellow glow, and against this will be seen the dark retinal blood vessels ramifying in various directions like the branches of a tree. . . . As the focus of the lens is moved to and fro over the sclerotica, the branched figure accompanies the motion proceeding always ‘with’ the illumination. By such movements the vascular ‘tree’ is more clearly visible than with the light kept stationary on one spot.” This arborescent vocabulary was a pervasive feature of scientific and medical literature on the eye in the 1880s and remains so up to the present day.¹⁵⁸

other small variations. Now, however, after habituating myself to examine it with the same sort of strain that one tries to decipher a signpost in the dark, I have found that this is by no means the case, but that a kaleidoscopic change of patterns and forms is continually going on, but they are too fugitive and elaborate for me to draw with any approach to truth; I am astonished at their variety, and cannot guess in the remotest degree the cause of them; they disappear out of sight and memory the instant I begin to think about anything, and it is curious to me that they should be so certainly present and yet be so habitually overlooked.” Galton, *Inquiries into Human Faculty and Its Development* (London: Macmillan, 1883), pp. 158–159.

156. James, *Principles of Psychology*, vol. 2, p. 241.

157. Hermann von Helmholtz, *Treatise on Physiological Optics*, ed. James P. C. Southall (New York: Dover, 1962), pp. 431–432.

158. See, for example, a standard text, R. L. Gregory, *The Eye and Brain: The Psychology of Seeing*, 4th ed. (Princeton: Princeton University Press, 1990), p. 64, in which the blood vessels are described as a tree with many branches. Illustrations of the vascular “tree” appear three times in the 1867 French translation of Helmholtz’s work (*Optique physiologique*, pp. 31, 215, 254). Ernst Mach used the terms “sight phantasms,” borrowed from Johannes Muller, to describe entoptical phenomena, including the retinal blood vessels, and recounted: “On a number of successive days, a bright red capillary net (simi-

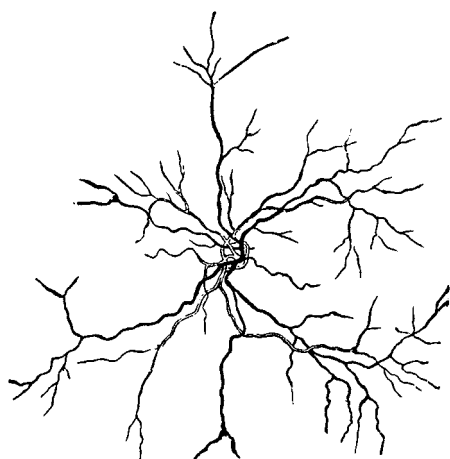

*Retinal blood vessels, or vascular “tree,”
from French edition of Helmholtz’s
Physiological Optics, 1867.*

Thus it might be possible to read an additional significance onto the tree at the left in *Parade de cirque*; that is, it could be both a tree and an allusion to the retinal tree as a sign of the body’s own inscription of itself onto a perceptual field, a binding of the physical eye to the structure of a visible world. Helmholtz’s book would have provided Seurat a map of a vision never detached from its own subjective corporeal conditions (and it would be difficult to reject the possibility of Seurat responding creatively to the most celebrated and influential book on vision available in 1887).¹⁵⁹ It allows another problematization of what the work “represents”: the eye’s self-perception of its own operation, the schematic contents of an objective world, or both. The study of physiological optics made clear that the photoreceptors in the human eye are placed at the back of the retina, behind the blood vessels; that is, the blood vessels literally intervene between the organ of seeing and what we see. It is another dramatization of the distinction between this new

lar to a so-called enchanted net), shone out upon the book in which I was reading, or on my writing paper. . . . When we withdraw the retina from outward excitations and turn the attention to the field of vision alone, traces of phantasms are almost always present.” Mach, *Contributions to the Analysis of the Sensations*, pp. 87–88.

159. By 1887, when Seurat planned and began *Parade de cirque*, this aspect of Helmholtz’s work had already penetrated mainstream cultural circles in France. See, for example, the discussion in Alfred Fouillee, “La sensation et la pensee selon le sensualisme et le platonisme contemporains,” *Revue des Deux Mondes* 82 (July 15, 1887), pp. 398–425: “Helmholtz has shown, in his *Physiological Optics*, how there are visual sensations which we do not perceive—blind spots, *mouches volantes*, afterimages, irradiations, chromatic fringes, marginal changes of color, double images, astigmatism, movements of accommodation and convergence, retinal antagonism, etc.” Also, the widely read work of Hippolyte Taine incorporated a wide range of Helmholtz’s observations. Taine’s claim that the apparent external world was in fact the play of “internal visual phantasms” referred directly to *Physiological Optics*. See Taine, *On Intelligence* (1869), trans. T. D. Haye (New York: Holt and Williams, 1872), pp. 285–337.

diagram of the eye and the model it displaced—the ideal, unobstructed functioning of the camera obscura. *Parade de cirque's* granular microstructure of divided color corresponds to the productive activity of the rods and cones within the retina, which Helmholtz indicated to be a highly dense “mosaic” of sensitive receptors, and the evocation of the vascular tree would be a figuration of the physical thickness of the eye that requires light to pass through a network of blood vessels and layers of nerve fiber in order to reach the optic nerve. *Parade de cirque*, I believe, has to be engaged as an inseparable mix of an abstract mathematically constructed space *and* a physiological perception more subjectively determined than anything Riegl might have been able to imagine. This plural surface of *Parade de cirque* is a fusion of opposites, an audacious attempt at overcoming the division of subject and object, at approximating that primordial (or infantine) dream of unification, of an unassailable immediacy.¹⁶⁰ We could thus read the tree's branches as “the veins through which the domain of vision has been integrated into the field of desire.”¹⁶¹ It is one more way in which *Parade de cirque* abandons a *scene* of representation and affirms phantasmic events that occur on the surface of bodies.¹⁶²

According to Jean-François Lyotard, it would be a mistake to attribute to the scenographic model of representation a distinct historical identity that has somehow been superseded. He maintains that the figure of the cube, the theater, the volumetric closure of representation has an enduring function within the economy of instinctual life. This cube or box can emerge anywhere, anytime, as a result of a particular (reactive) configuration of libidinal energy, or of a particular immobilization and objectification of the body. For Lyotard, the effective truth of the body is that it is a surface, what he calls a “band,” with a variable geometry, a Mobian skin

160. The dream of immediacy in Seurat's work is the fantasy of a theater without representation. In this sense the refusal of scenography, the nondisclosure of *Parade de cirque* also constitutes the imaginary conditions for the primordial event of festival. In Derrida's account of Rousseau's affirmation of political self-sovereignty, festival is “*a stage which presents nothing to the sight*. It is the place where the spectator, presenting himself as spectacle, will no longer be either seer or voyeur, will efface within himself the difference between the actor and the spectator, the represented and the representer, the object seen and the seeing subject. With that difference, an entire series of oppositions will deconstitute themselves one by one. . . . Presence will be full as the intimacy of a self-presence, as the consciousness or the sentiment of self-proximity, of self-sameness.” Derrida, *Of Grammatology*, trans. Gayatri Spivak (Chicago: University of Chicago Press, 1976), p. 306; emphasis added.

161. Lacan, *Four Fundamental Concepts of Psycho-analysis*, p. 85.

162. For Deleuze, the phantasm is an effect that “transcends inside and outside, since its topological property is to bring its internal and external sides into contact, in order for them to unfold onto a single side.” Deleuze, *The Logic of Sense*, trans. Constantin V. Boundas (New York: Columbia University Press, 1990), p. 211.

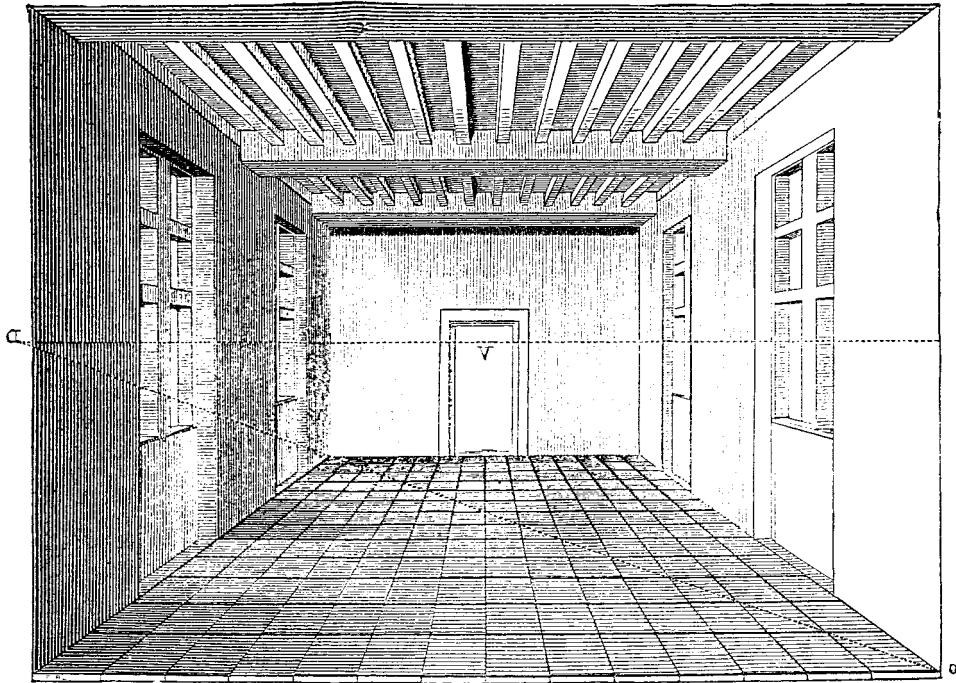

Perspectival cube, from 1880 edition of Charles Blanc, *Grammaire des arts du dessin*.

with no inside or outside, on which it is impossible to assume *a position*.¹⁶³ Yet it is this band or surface that is continually susceptible to being reshaped into a representational schema of presence and absence, interiority and exteriority.¹⁶⁴

163. Lyotard describes the band or the bar as “intensities running here and there, setting up, escaping, without ever being imprisoned in the volume of the stage/auditorium. Theatricality and representation, far from having to be taken as libidinal givens, *a fortiori* metaphysical, result from a certain labor on the labyrinthine and Moebian band, a labor which prints those particular folds and twists, the effect of which is a box closed upon itself, filtering impulses and allowing only those to appear on the stage which come from what will be known as the *exterior*, satisfying the conditions of interiority. The representative chamber is an energetic dispositif.” Jean-François Lyotard, *Libidinal Economy*, trans. Iain Hamilton Grant (Bloomington: Indiana University Press, 1993), p. 3. See also Lyotard’s discussion of “theatrical” space in *Des dispositifs pulsionnels* (Paris: Christian Bourgeois, 1973), pp. 95–102.

164. The Möbius strip, a nineteenth-century invention, is a crucial theoretical model for analyzing constructions of embodied subjectivity in Elizabeth Grosz, *Volatile Bodies: Toward a Corporeal Subjectivity* (Bloomington: Indiana University Press, 1994), p. xii: “The Möbius strip has the advantage of showing the inflection of mind into body and body into mind, the ways in which, through a kind of twisting or inversion, one side becomes another. This model also provides a way of problematizing and rethinking the relations between the inside and outside of the subject, its psychical interior and its corporeal exterior, by showing not their fundamental identity or reducibility but the torsion of one into the other, the passage, vector, or uncontrollable drift of the inside into the outside and the outside into the inside.”

Within Lyotard's particular revision of a Freudian schema, the inner theater takes shape as the result of excitations slowing down and becoming "bound," thus acquiring fixed positions and identities. The destruction of the trapezoidal semblance of the cube in *Parade de cirque* is inseparable from the postulation of the body as a surface, as a retina that is a heterogeneous field of sensitivities, as a nervous system circulating intensities and forces, reverberating through all different organs, a system with the possibility of states of relative equilibrium but more importantly a system in transition and oscillation. And for Seurat it is through the currents and surfaces of this body that there will be temporary coalescences of energy into images and phantasms, into the deceptive semblance of a theater of representation as in *Parade de cirque*.¹⁶⁵

But if it's possible to read *Parade de cirque* through Helmholtz's work, it is not merely that the painting outlines the effects or operation of a subjective vision, of a vision determined by the physiological limits of the body. It is more that the knowledge of a whole range of subjective conditions and limitations becomes part of a reorganization of the status of epistemological "objectivity." In the 1885 publication of Mach's *Analysis of the Sensations* an illustration depicts the author's visual field as seen through one eye, a field that includes his nose, moustache, eyelashes, and lower body. Just as one very rarely is aware of entoptical phenomenon, like retinal blood vessels, in ordinary visual experience one is seldom conscious of the ways in which the body is continually present but effectively deleted out of one's visual perceptions. Classical representation, from Alberti onward, defines itself by the fundamental subtraction of the body from the constitution of a visual field and by the related intellectual distinction between observer and object.¹⁶⁶ Mach was trying to highlight how certain visual habits correspond to particular philosophical prejudices, and in his enduring attacks on philosophical dualism he sought to overcome classical distinctions between "inner" and "outer"

165. For Lyotard, the theater of representation is always occupied by an exchangeable figure for what is exterior to that interior space: he calls it Zero. This is the sign that occupies "the empty center, the place where everything is supposed to be visible and intelligible, the place of knowledge." Zero becomes the figure for God, the organized body, society, capital, the ego, Platonic forms, and so on. See Lyotard, *Libidinal Economy*, pp. 1–16.

166. Erwin Panofsky discusses Renaissance perspective in terms of its effacement of the body. "For the structure of an infinite, unchanging and homogeneous space—in short, a purely mathematical space—is quite unlike the structure of psychophysiological space. . . . In a sense, perspective transforms psychophysiological space into mathematical space. It negates the differences between front and back, between left and right, between bodies and intervening space so that the sum of all the parts of space and all its contents are absorbed into a single 'quantum continuum.' It forgets that we see not with a single fixed eye but with two constantly moving eyes, resulting in a spheroid field of vision." Panofsky, *Perspective as Symbolic Form*, pp. 30–31.

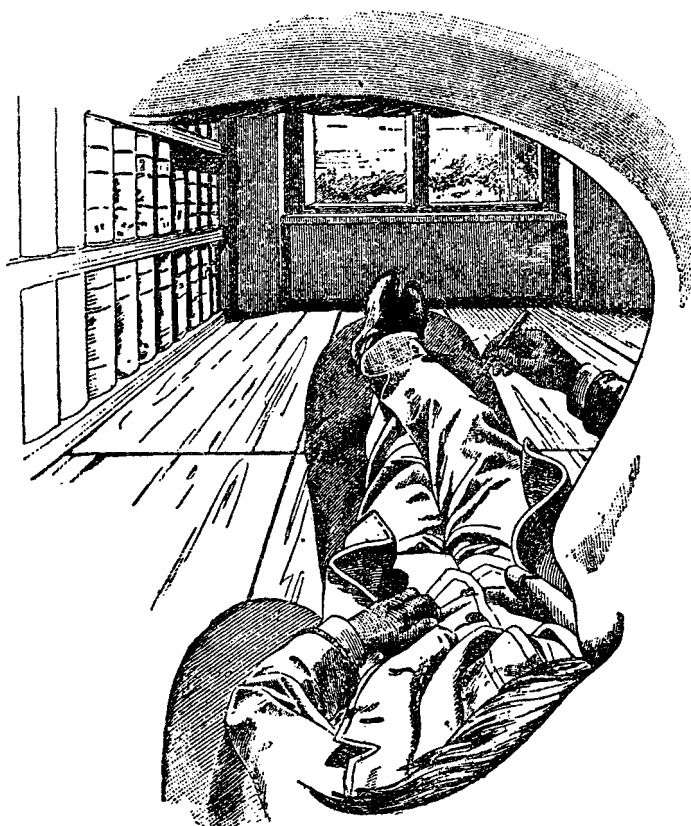

Ernst Mach, illustration from The Analysis of Sensations, 1885.

phenomena, between the physical and the psychic. The data of physiological experience were of crucial importance for him in demonstrating the interpenetration of these spheres. Though he shunned a monistic stance, any given phenomenon for Mach was an irreducible composite of properties belonging to the observer and features of the object observed, and certainly much the same could be asserted about Seurat's work after the mid-1880s: for both, the world was "one coherent mass of sensations."¹⁶⁷

167. Mach, *Contributions to the Analysis of the Sensations*, p. 23. "Mach's work constituted an effort to rescue the efficacy of science as a universal construct by retreating, so to speak, to the exclusive legitimacy of the act of perception. He generated a kind of legitimate, functional scientific impressionism." Leon Botstein, "Time and Memory: Concert Life, Science and Music in Brahms's Vienna," in Walter Frisch, ed., *Brahms and His World* (Princeton: Princeton University Press, 1990), p. 17.



How then to situate Seurat after the preceding speculations? It means rethinking my earlier remarks about the instrumentality of his method in relation to the “antiquarian” components of his project. Clearly Seurat must be considered as an artist deeply preoccupied with the modernization and rationalization of perceptual and aesthetic response, in the same way that this could be said of figures as diverse as, for example, Sergei Eisenstein, László Moholy-Nagy, and Arnold Schoenberg. One of the most suggestive summations of Seurat’s importance by an art historian is from the unlikely André Chastel, who associated him with the fictional composer Adrian Leverkühn in Thomas Mann’s novel *Doctor Faustus*, about the cultural crisis out of which National Socialism emerged. Seurat’s method, he writes, was “a research into archetypal forms (lines, colors, directions) which answered to a double and deliberately compounded ambition, at once archaic regression and scientific reduction. The painter’s operations set up a meeting point between an ancient hieratic art and the rationalized discipline of the future.”¹⁶⁸ This affiliation is important because it relocates the problem of Seurat into the midst of the most disturbing questions about modernity and rationalization. In hinting at a culturally reactionary component of Seurat’s project, it challenges those accounts that have dutifully and reductively identified his interest in science as inevitably allied with progressive political and social positions, as Meyer Schapiro began to do in the 1930s. Mann’s Leverkühn is far closer to the truth of Seurat in saying, “Most interesting phenomena probably always have this double face of past and future, probably are always progressive and regressive in one. They display the equivocalness of life itself,” as he defends his desire to fulfill the ancient aspiration of “resolving the magic essence of music into human reason.”¹⁶⁹ According to Chastel, in the domain of forms and colors Leverkühn’s ambition “bears the name Seurat.”¹⁷⁰ So it is not just that Seurat aligned himself with the scientific research of his own time

168. André Chastel, “Le ‘système’ de Seurat,” in *Seurat* (Paris: Flammarion, 1973), pp. 5–8. See the insistence that no notion of the modern “can in fact be constituted without reinventing its relation to the ancient. Indeed the modern consists wholly in such an invention,” in Philippe Lacoue-Labarthe, *Heidegger, Art and Politics*, trans. Chris Turner (Oxford: Blackwell, 1990), p. 58.

169. Thomas Mann, *Doctor Faustus*, trans. H. T. Lowe-Porter (New York: Knopf, 1948), p. 193.

170. Certainly Chastel is no Adorno, but his brief reflections that I’ve cited here contain more useful ideas with which to evaluate Seurat than some of the influential conclusions of Meyer Schapiro, to which I have already alluded. Who in fact is Schapiro’s Seurat? An enlightened, politically progressive artisan-artist embracing science and technological paradigms in the interests of forging an image of a nonhierarchical social world. Schapiro’s uncritical stance toward “science” and “technology” is obviously the product of a specific political and intellectual moment, but it is nonetheless regrettable that he approached “the rationality of method” in Seurat as a final locus of meaning rather than as the site of powerful and unresolved contradictions.

but that he sought confirmation anywhere (whether in the theories of Henry or those of Humbert de Superville, in the art of Egypt, Greece, or Delacroix) for the idea of a universal formula that would make rational and controllable the effects of color and form. In this sense, Ernst Bloch justifiably insisted on the “troublesome” ambivalence of Pythagoreanism: he understood that it was part of an animistic, premodern magical world view and yet deeply embedded in the essential assumption of modernity that all of nature is understandable in terms of number: “There is not even a sharp distinction between this mythical heritage and the new mathematical quantitative calculus” of modern thought.¹⁷¹ Similarly, all of Seurat’s late paintings, but especially *Parade de cirque*, must be seen in terms of his unresolvable problem—to think simultaneously the idea of universality in terms of aesthetic absolutes *and* the inescapable universality of modern exchange and circulation. It means stepping outside of an opposition between a social legacy of symbolic practices on one hand and the economic imperatives of high capitalism, and moving toward some of the proposals of Norman O. Brown and other historians. For Brown, “the money complex, archaic or modern, is inseparable from symbolism; and symbolism is not, as Simmel thought, the mark of rationality but the mark of the sacred. . . . At any rate, the historian must conclude that the ideal type of the modern economy retains, at its very heart, the structure of the archaic sacred. And once again the undialectical disjunction of sacred and secular is seen to be inadequate.”¹⁷² For too long, art historical work on Seurat consisted of empirical analyses in which his method was objectively interrogated and evaluated as either a success or failure. Much recent writing has engaged in pointless and often unreadable demonstrations that he “misunderstood” this or that scientific theory. Rarely articulated is the profound irrationality of his project, the excess, obsessiveness, sexual confusion, and paranoid secrecy that saturate the whole enterprise

171. The quotation is from a discussion of Kepler in Ernst Bloch, *The Utopian Function of Art and Literature*, trans. Jack Zipes and Frank Mecklenburg (Cambridge: MIT Press, 1988), pp. 60–61. Elsewhere Bloch’s assessment is somewhat different: “It was only in the modern era that the rift or schism began which, since Kepler at the latest, has opened between the *two sides of Pythagoreanism*. Between the quantitative side, on which metaphysics proper, which has been strictly scientific, developed, and the figural-qualitative, symbolic side on which so-called ‘holy mathematics’ was supposed to dwell. The latter had grown on a different social foundation than that which ultimately was interested solely in methods of calculation and the quality-less world corresponding to it.” Bloch, *The Principle of Hope*, vol. 3, p. 1350.

172. Norman O. Brown, *Life against Death: The Psychoanalytical Meaning of History* (Middletown, Conn.: Wesleyan University Press, 1959), pp. 247–248. For a different articulation of this problem, see John Brenkman, “Theses on Cultural Marxism,” *Social Text* 7 (Spring–Summer 1983), pp. 19–33: “Aesthetic experiences occur within, not above, the opposition of the symbolic and the economy, and within the lived conflict between self-activity and reification.”

and for which the surface of control, detachment, and logical rigor is merely a necessary mask.¹⁷³ (A rigid and unlikable person, he reminded Degas of a “notary,” while Emile Verhaeren compared him to a “silent reflective monk.”). What has put viewers off for over century, what is seen in his work as the graceless, mechanical assemblage of never quite integrated elements—this is not the result of an overly logical or merely misinformed application of theory. The unsettling (even if apparently bland) texture of the work derives from one thing above all else—an intuition of the loss of art’s immediacy; and Seurat’s relentless efforts to construct substitutes for that lost presence result from a parallel intuition of the shift of what might have been contemplation into mere attentiveness. We can certainly identify the instrumental character of Seurat’s art, but at the same time it cannot be understood in terms of some easy model of ascendant technocratic imperatives in the late nineteenth century. Seurat stands for that tragic subsumption of ends within the demands of a technical system whose rational extension becomes perpetually self-justifying. Thus attention in Seurat is finally attuned only to its immanence within that operation or imposition of system, even as it masks itself in luminous or spectacular surfaces, even as attention might be indistinguishable from the fluctuating tensions and relaxations of the body.

To put it another way, Seurat’s work concretizes the modern dilemma of the disappearance of aura more acutely than any other art practice. It can be reason-

173. The delirious psychobiography of Seurat has yet to be written; but the paucity of documentary traces of his relation to his extraordinary father will probably never allow him to emerge as a modernist “case” to rival Kafka’s or others. Antoine-Chrysostome Seurat was a figure in whom the psychotic borderlines of bourgeois male social identity in the nineteenth century were approached if not actually crossed. To designate the father’s condition simply as an “extreme obsessive-compulsive disorder” does not adequately address the overlapping of juridical, familial, and religious derangement in the conduct of his life. He was a court functionary (the bailiff and a notary in the La Villette district of Paris), a husband and father who lived separately and only returned home every Tuesday, with absolute regularity, to perform his conjugal duties, and a religious fanatic who decorated the walls of his home floor to ceiling with popular prints of Jesus, the Virgin, and saints and who, to the dismay of local church authorities, styled himself a “priest,” performing mass in his wine cellar for local peasants with the help of his gardener. In the face of this formidable paternal “desiring machine,” various reports reiterate the same predictable refrain: that Seurat was doted on by his mother, and that his own investment in the maternal bond was considerable. To add to the interpretive plenitude, Seurat’s father had lost part of his arm as a young man and been fitted with a mechanical prosthetic device, which, ominously, as Mary Gedo relates, he could use so dextrously “that he could neatly carve and distribute a roast, slice by slice, impaled on his hook.” The phantasmic impact of this artificial hand could be part of an extended reading of Seurat’s own development of a “mechanized,” repetitive touch (not to mention the “prosthetic” quality of the metallic trombone in *Parade de cirque*). For some of the few attempts to work interpretatively with these elements of Seurat’s life, see Gedo, “The *Grande Jatte* as the Icon of New Religion”; and S. Hollis Clayson, “The Family and the Father: The *Grande Jatte* and Its Absences,” *Art Institute of Chicago Museum Studies* 14, no. 2 (1989), pp. 133–154. For biographical information, see the relevant sections in Henri Perruchot, *La vie de Seurat* (Paris: Hachette, 1966).

ably claimed that his paintings are the first attempt to rationally produce aura, and his “theories” an attempt to concoct its formula.¹⁷⁴ His immersion in the mechanics of vision was directed to the creation of a luminosity with no direct material substrate, of a chromatic unfolding existing apart from the mere objectivity of the work, that “appears” only in a subjective, even “interpersonal” relation to it. But even to attempt the creation of this luminous effect means bringing into the work the forms of rationalization that eradicated aura in the first place.¹⁷⁵ It is then no accident that his last major paintings are experiments in simulating different artificial forms of illumination, and that he situates both artist and spectator in a world bereft of “natural” white light, where the opposition of day and night is dissolved. The gas lighting across the top of *Parade de cirque* (to which its whole chromatic organization in principle refers) is itself a symbolic conjoining of all its luminous effects into larger networks of quantification and circulation, even as it simulates an acanthus motif from antique architecture.¹⁷⁶ The horizontal tubing connecting the lamps is a literalization of a line out of the nocturnal field of the image into the economic flows of urban space, leading finally to the huge squat gasometers on the outskirts of Paris, which Seurat well knew and which Paul Signac had painted a few years before.

Parade de cirque itself is a field of different kinds of artificial light: the gas lamps, the apparent aura or halo around the figures, and the photochemical

174. I use the word *aura* overlapping its literal meaning of “luminous radiation” with the associations loaded onto it in the work of Walter Benjamin. In *Parade de cirque*, the original sense of aura as “nimbus” is directly relevant to Seurat’s creation of glowing fields of light around his human figures.

175. This reversal, in which appearance is privileged over essence and technological rationality is deployed in the service of appearance, is, as we will see, one of the possible ways to associate Seurat with Richard Wagner. See the relevant discussion of Walter Benjamin’s notion of the “dialectical image” in Georges Didi-Huberman, “The Supposition of the Aura: The Now, the Then, and Modernity,” in Richard Francis, ed., *Negotiating Rapture* (Chicago: Museum of Contemporary Art, 1996), pp. 48–63. To produce a dialectic image “is to criticize modernity (the forgetting of the aura) through an act of memory and, at the same time, to criticize archaism (nostalgia for the aura) through an act of essentially *modern* invention, substitution and designification. Benjamin dismissed with the same gesture myth and technology, dreaming and waking, Carl Jung and Karl Marx” (p. 53).

176. As many have indicated, gas lighting in 1888 was somewhat outmoded in relation to new forms of electric arc lighting, which began to illuminate urban spaces by the early 1880s. But Wolfgang Schivelbusch has demonstrated that, even in 1890, the experience of nocturnal urban space was a patchwork of major central areas lit by incandescent light and a far more extensive area of secondary streets and spaces still lit by gas. Schivelbusch shows how a pedestrian experienced abrupt and disorienting optical shifts due to adjacent but radically different luminous environments: “The arc-light was, in fact, a small sun and the light it cast had a spectrum similar to that of daylight. In arc-light, the eye saw as it did during the day, that is with the retinal cones, while in gaslight, it saw as it did at night, with retinal rods. Stepping from an arc-lit into a gas-lit street fully activated the eyes’ mechanism for adapting to the dark.” Schivelbusch, *Disenchanting Light: The Industrialization of Light in the Nineteenth Century*, trans. Angela Davies (Berkeley: University of California Press, 1988), p. 118.

interaction of Seurat's pigments. It has been claimed many times, of course, that Seurat's divisionist technique resembles this or that technological innovation, from three-color printing processes in the 1880s to the mosaic of photoelectric cells in color television.¹⁷⁷ Regardless of the value of any such individual comparison, it is important to see that his experiments in search of a chromatically charged screen are part of a larger development described by Paul Virilio as the loss of direct vision, "the disintegration of a faith in perception," the reconfiguration of optical experience into synthetic and machinic operations that occur external to the observing subject.¹⁷⁸ One of the paradoxes of his decomposition of color is that it retains something of the attraction of an alchemical process. Seurat has to be understood outside of the now pervasive and misleading polarity between a romantic Goethean tradition of expressionistic color theory (northern and eastern European) and a modernizing quantitative color theory deriving from Chevreul, supposedly dominant in France. To characterize Seurat as representative of the latter is to miss how the methodical program of his technique is an attempt to conceal the parallel (even if hopeless) ambition of an alchemical transubstantiation, of overcoming the opacity and materiality of pigment to attain that archaic goal of, in Toulmin and Goodfield's phrase, "the redemption of matter."¹⁷⁹ One of the central questions about Seurat's work is the extent to which forms of synthesis (optical mixture) produce *qualitative* change. The purely additive and accumulative functions of industrialized procedures, which insinuate the most basic forms of modern social reproduction into the work, are haunted by the survival of what Bloch calls "a pre-bourgeois, non-quantitative connection to nature," for which color did not exist as an autonomous experience or as a separate and specialized science.¹⁸⁰ It must be recognized how Seurat's equivocal quest for an axiomatic of aura, and his

177. See, for example, Norma Broude, "New Light on Seurat's Dot: Its Relation to Photomechanical Color Printing in France in the 1880s," *Art Bulletin* 56 (December 1974), pp. 581–589, or Marshall McLuhan, *Understanding Media: The Extensions of Man* (New York: McGraw-Hill, 1965), p. 190.

178. Paul Virilio, *The Vision Machine*, trans. Julie Rose (Bloomington: Indiana University Press, 1994), p. 16.

179. Stephen Toulmin and June Goodfield, *The Architecture of Matter* (Chicago: University of Chicago Press, 1962), pp. 109–136. See the account of how premodern notions of transubstantiation remained influential in the nineteenth century and overlapped with the terms of both philosophical and scientific materialism, as well as thermodynamics, in Michel Serres, *Feux et signaux de brume: Zola* (Paris: Grasset, 1975), pp. 237–244.

180. Bloch, *The Utopian Function of Art and Literature*, p. 63. The complicated problem of Seurat's additive and "repetitive" technique (and its latent resistance to modernity) is suggested by Adorno: "It is impossible to consider the emphatic aesthetic idea of the new apart from the industrial procedures that increasingly dominate the material production of society. . . . Industrial techniques, however, the repetition of identical rhythms and the repetitive manufacture of an identical object based on a pattern,

desire for a luminous surface of fascination, are in fact the consequences of a colossal *disappointment* at the impossibility of immediacy and the historical inaccessibility of the dream of a ritual/magical practice of art. The work's exhaustive denial of presence incites the pursuit of another kind of immediacy: the fusing of eye and image as an attempt to overcome the absence figured in the work. Of course we can still situate Seurat within a familiar field of painters and their related aims and problems, as a member of what Paul Valéry called "the cult of light," but more importantly his work migrates toward a location outside some long-held assumptions about the arts, toward an abandonment of the idea that art is a medium for disclosing essential truths. There is also, in *Parade de cirque*, though I say this more conditionally, an abandonment of a redemptive optimism about art: it is a work in which the Apollinian veil, which Seurat sustained so tautly in some other works, is pitilessly pulled aside to reveal a void, glittering but menacing, behind it.



I want now to align my discussion of *Parade de cirque* more closely with some of the ways in which attention and perceptual response were being remade in institutional and social spaces. To do this, I return to the endlessly plural trombone player and its ambivalent construction. Having suggested its position within a desiring system dependent on operations of rebinding and immobilization, I want to examine the dissonance of this figure in terms of Seurat's language of unresolved opposites, and more specifically through his enduring preoccupation with the problem of *contrapposto*. His conceptual approach to the representation of the body, which developed in relation to this formal principle, was formed in the late 1870s both through his studies of antique works, studio models, and copies from Ingres and through his reading of various aesthetic and scientific treatises. As David Summers has shown, the Renaissance ideal of *contrapposto* invoked a metaphysical dualism that found expression in rhetorical devices of contrast and antithesis. Both the familiar notion of sculptural *contrapposto* and *chiaroscuro* (contrast of colors) were subsumed within the larger ideal of *opposition*. According to Summers, "*Contrapposto* could be decorative or structural. . . . Its final justification lay in its vividness, the clarity with which art by direct contrast could make opposites evident, or bring them into harmony. On this level antithesis touched

at the same time contain a principle antithetical to the new. This exerts itself as a force in the antinomy of the aesthetically new." Theodor W. Adorno, *Aesthetic Theory*, trans. Robert Hullot-Kentor (Minneapolis: University of Minnesota Press, 1997), p. 272.



Georges Seurat, Praxitolean Figure, early 1880s.

on basic principles and there was a continuous relation between nature, or our knowledge of nature, and art.”¹⁸¹ But just as Seurat demolished the structural conditions of classical scenography yet maintained a suggestion of its effects, he self-consciously negates the possibilities of classical contrapposto even as he presents the central figure in terms of a principle of “contrast”; for its discordant formation is remote from any notion of a harmonious continuity between nature and art.

The contrast set up in the trombone player elicits two seemingly incompatible modes of perceptual response. The top half of the figure, which clearly tends to dominate one’s apprehension of the work, is defined by the frontal and hieratic timelessness of archaic art.¹⁸² As such it presupposes a rapt, frozen attentiveness,

181. David Summers, “Contrapposto: Style and Meaning in Renaissance Art,” *Art Bulletin* 59 (September 1977). p. 357.

182. For an extended consideration of the formal characteristics of archaic or “primitive” Greek art, see Emanuel Loewy, *The Rendering of Nature in Early Greek Art*, trans. John Fothergill (London: Duckworth, 1907), pp. 5–75. For Humbert de Superville, the vertical axis of the human body had an originary and transcendent significance, in that an upright man was “turned toward heaven.” But he also identi-

caught up in the magical attraction of this object.¹⁸³ Yet the lower half of the body, in its willful yet almost careless deviation from a symmetrical relation to the central axis, in its casual shifting of the hips and distribution of weight onto the left leg, would seem to be an “awakening” out of the “archaic spell,” implanting the figure in the dynamic temporalities of autonomous movement. This at least was how contrapposto in classical art often came to be understood, as suggesting “a living organism controlled by an indwelling will, a person capable of acting spontaneously.”¹⁸⁴ But Seurat decisively repudiates that classical image of the body as an expression of a self-determining balance of internal forces. Instead, the lower half of the body seems severed from a sense of any unified autonomous will, and the legs seem as if swept by some external agency so far to the left of the vertical axis of the figure that there is no effective support for the impassive upper body. The lower legs, like wooden pegs, seem almost unanchored, as if the figure was a skillfully managed marionette, only tenuously abutting the ground.¹⁸⁵ In a more general sense, these limbs seem like parts of a mechanical apparatus rather than integrated components of human movement. Meyer Schapiro intuited something that remains essential for our understanding of Seurat when he pointed to his proximity to a range of modernizing technological practices, in particular to what Schapiro called “a taste for increasingly schematic movement.”¹⁸⁶ I would suggest that this could be specified further as movement both mechanical and automatic, which finally brings me back to the question of the *dissonance* of this figure. Rather than an incongruous composite of the frontality of archaic art and the harmonious oppositions of classical art, the figure suggestively elides the regressive immobility of trance with the machinic uncanniness of automatic behavior.¹⁸⁷

fied in the frontal verticality of archaic art “an innate and primitive expression of death.” See the opening paragraphs of his “Essay on the Unconditional Signs in Art” (1827), in *Miscellanea Humbert de Superville*, ed. Jacob Bolten (Leiden, 1997), p. 68.

183. Obviously the association of motionlessness with frontal, hieratic images is a qualified one. For example, in a discussion of twelfth-century icons, Hans Belting insists that “authentic images seemed capable of action, seemed to possess *dynamis*, or supernatural power. God and the saints also took up their abode in them, as was expected and spoke through them.” Belting, *Likeness and Presence: A History of the Image before the Era of Art*, trans. Edmund Jephcott (Chicago: University of Chicago Press, 1994), p. 6.

184. Denys Hayes, *Greek Art and the Idea of Freedom* (London: Thames and Hudson, 1981), p. 33.

185. During the late 1880s, there were several popular venues in Paris offering “theatrical” performances of marionettes, such as the “Maquettes animees” at the Alcazar d’Hiver theater where marionettes, three feet in height and made out of rubber, appeared as clowns, circus performers, and musicians. Jules Cheret designed a poster for this particular show.

186. Meyer Schapiro, *Modern Art, 19th and 20th Centuries: Selected Papers* (New York: Braziller, 1978), pp. 101–110.

187. Part of the dilemma presented by a more complete range of Leonardo’s notebooks in the late 1880s was how to reconcile his insights into “natural” movements and rhythms of living beings with

Seurat's late work is an exploration of subjective vision and its epistemological consequences, but also coincides with an understanding of perception and attention as inextricable parts of a social field of collective response. His representations of the crowd (or the crowd as a figure for the social) occur in a short-lived historical moment when hypotheses and statements about hypnosis, suggestibility, and automatic behavior (in terms of both individual and collective subjects) were not only permissible but widespread.¹⁸⁸ As I indicated earlier, the volatility of hypnosis as a cultural and scientific object was due to its dual status as a potential technique of control and a set of enigmatic phenomena that resisted intellectual mastery and dualistic conceptualizations. To historicize this ambivalent duality more fully, it is important to recall that the apogee of hypnosis as an object of institutional preoccupation may well have been in 1889, with the symbolic event of the First International Congress on Hypnotism held August 8–12 of that year in Paris.¹⁸⁹ It thus coincided with the great Universal Exposition of the same year, which is significant for several reasons. First, it aligned the public gathering of researchers on hypnosis (from all over Europe and North America) with the rationalizing ideological imperatives of the young Third Republic, imperatives that were concretized in the actual organization and layout of the Exposition and that had

his invention of diverse forms of repetitive mechanical motion. The impact of Leonardo's machinic studies in the late nineteenth century are discussed in Georges Canguilhem, "Machine and Organism," in Jonathan Crary and Sanford Kwinter, eds., *Incorporations* (New York: Zone Books, 1992), pp. 44–69. See the discussion of Leonardo in relation to the ambiguous history of automatons—of his production, on one hand, of the premodern machinery of court festivals and theater, and his conceptualization, on the other, of regularized proto-industrial forms of machinic processes—in Jean-Claude Beauce, *L'automate et ses mobiles* (Paris: Flammarion, 1980), pp. 76–88.

188. By the late 1880s, a huge amount of research and reflection on the problem of automatic behavior had been produced. Within psychology a key text was, as we have seen, Janet's *L'automatisme psychologique* (1889), in which he demonstrated the automatic components of perception, memory, and attention. Various philosophical debates still made reference to the "automata hypothesis" of Thomas Huxley, according to which consciousness was a mere epi-phenomenon, a superfluous addition to the operation of physiological processes. See Thomas H. Huxley, *Collected Essays*, vol. 1 (New York: D. Appleton, 1917), pp. 199–250. See, for example, the use of Huxley's hypothesis in relation to the study of automatisms in Alfred Binet, *On Double Consciousness* (Chicago: Open Court, 1890), p. 20. The larger historical resonances of this problem are implicit in Charcot's insistence that "the movements which exteriorly represent the acts of unconscious cerebration are distinguished by their automatic and purely mechanical character. Then it is truly that we see before us the *human machine* of De La Mettrie." Charcot, *Clinical Lectures on Diseases of the Nervous System*, p. 290.

189. On the proceedings at the Congress, and the open battle between the Nancy and Salpêtrière schools, see François Duyckaerts, "1889: Un congrès houleux sur l'hypnotisme," *Archives de Psychologie* 57 (1989), pp. 53–68. The exchange of ideas at the Congress is also discussed in Leon Chertok, "On the Discovery of the Cathartic Method," *International Journal of Psycho-analysis* 42, no. 3 (1961), pp. 284–287. Chertok emphasizes the almost simultaneous meeting in Paris of the first International Congress of Psychology (August 6–10, 1889), which had an important section devoted to hypnotism, and that many participants moved back and forth between the two events.

their “roots in the Enlightenment faith in man’s limitless potential for mastery of his environment.”¹⁹⁰ The Congress on hypnosis clearly paralleled these same objectives: hypnosis, for most of the participants, was optimistically seen as the most effective entryway into previously inaccessible territories and processes of human psychic life, and as a means of exploring, studying, and hopefully mastering this terrain, with the goal of new solutions and cures to both the mental and physical ills of human beings. Secondly, the Exposition of 1889 was unprecedented for its extensive presentation of colonial peoples and lifestyles as object of spectacle. Simulated “villages” inhabited by Congolese, Javanese, New Caledonians, Senegalese, and others became contents of an imaginary imperial space, contents that were supposedly assimilable into the rationalizing “taxonomy” of the exposition’s organizational schema.¹⁹¹

These events in the summer of 1889 were emblematic of a historical moment when both hypnosis and the material life of colonial peoples took on a public, and more specifically an *exhibitionary* existence at the threshold of their marginalization, assimilation, or disappearance. Obviously these are two very different historical objects, but both hypnosis (with its profoundly indecipherable trance states) and primitive cultures (with their singular forms of exchange, of value and power relations) were radically irreconcilable with dominant forms of Western rationalism. What was unassimilable in both was at least temporarily refigured as the survival (or simulation) of an earlier stage of development, as a lower, regressive, or childlike state of mind or culture. Hypnosis, as researchers disturbingly realized throughout the 1890s, placed familiar notions of individual identity in jeopardy. “Suggestion and hypnosis have always designated for Western rationality its own particular antithesis: influence without any logical foundation, and the production of an illusory relation with the world. . . . In other cultures, this is hardly the case; states of trance whether individual or collective are conceived as an opening up and a sharing.”¹⁹²

190. Deborah Silverman, “The 1889 Exhibition: The Crisis of Bourgeois Individualism,” *Oppositions* 8 (Spring 1977), pp. 71–91.

191. On the relation between the rise of anthropology as a discipline in the 1870s and the 1889 Exposition, see the discussion in Paul Greenhalgh, *Ephemeral Vistas: The Expositions Universelles, Great Expositions and World’s Fairs, 1851–1939* (Manchester: Manchester University Press, 1988), pp. 84–90. On the exposition’s “taxonomic” organization, see Silverman, “The 1889 Exhibition,” pp. 78–80.

192. Leon Chertok and Isabelle Stengers, *L’hypnose: blessure narcissique* (Paris: Les Empecheurs de penser en rond, 1990), p. 55. See the remarkable discussion of trance in various non-Western and premodern societies, where “trance constitutes a cultural model integrated into certain general representations of the world,” rather than simply a modality of individual experience, in Gilbert Rouget, *Music and Trance: A Theory of the Relation between Music and Possession*, trans. Brunhilde Biebuyck



Colonial village exhibition at Exposition Universelle, Paris, 1889.

In short, hypnosis, like the colonial villages at the 1889 Exposition, had its own *spectacular* identity. Well before Charcot's "performances" at the Salpêtrière in the 1880s, hypnosis had existed throughout much of the nineteenth century as a pervasive form of popular entertainment.¹⁹³ Frequently it would be the centerpiece of the quasi-scientific lecture or demonstration, a specifically nineteenth-century form of didactic entertainment. Just as often, however, the performance of a "magnetiseur" was itself a form of spectacle within a milieu of magic shows, of

(Chicago: University of Chicago Press, 1985). See also Paul Stoller, "Son et transe chez les Songhay du Niger," in Daniel Bougnoux, ed., *La suggestion: Hypnose, influence, transe* (Cerisy: Les Empêcheurs de penser en rond, 1991), pp. 145–161.

193. One of the most famous "magnetiseurs" was Charles Lafontaine, whose traveling show appeared across Europe between 1840 and 1852. Accompanied by music, subjects rendered insensible were pierced with hatpins and young working-class women were "ecstatically transfigured" into St. Theresa. See his *Memoires d'un magnetiseur* (Paris: Balliere, 1866). See also the discussion in Jacqueline Carroy, *Hypnose, suggestion et psychologie: L'invention de sujets* (Paris: Presses universitaires de France, 1991), pp. 89–96.

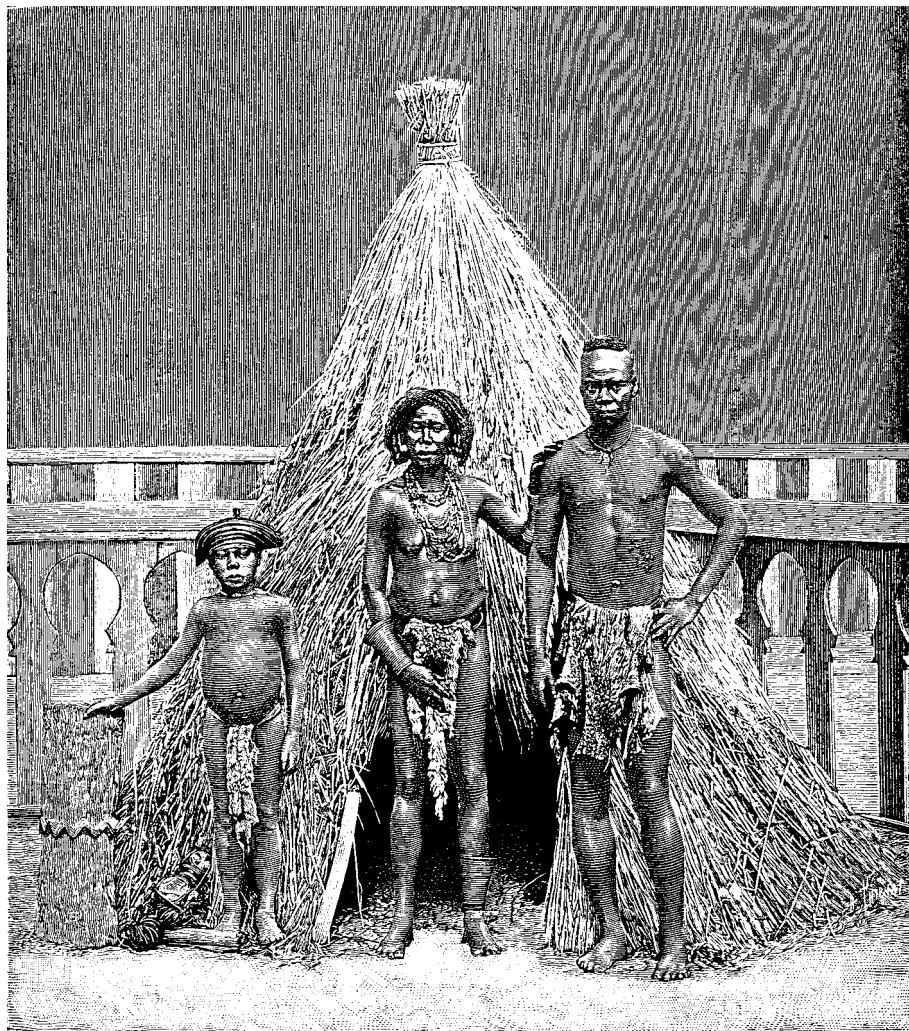

Illustration from La Nature, 1889. Original caption reads: "Man, woman, and child from the band of Angolans exhibited at the Paris Exposition."



Le gladiateur



Le mal de dents

Hypnotized subjects: one believes he is a gladiator; the other that he has a toothache. Late 1880s.

music hall and proto-vaudeville acts.¹⁹⁴ In fact, many of the important researchers associated with hypnosis in the nineteenth century, including Braid, Charcot, Freud, and the American psychologist G. Stanley Hall, were first exposed to hypnotic practices through such “theatrical” displays and, notably, were convinced by them that there was something important and authentic to study further.¹⁹⁵ One of the best-known hypnotist-showmen was the Dane Carl Hansen, whose performances were seen across Europe between 1879 and 1884, and his audiences at various times included Bernheim, Freud, Wundt, and Krafft-Ebing, among others.¹⁹⁶ Hansen’s entertainment included compelling his subjects to assume cataleptic postures, as well as “engaging in preposterous pantomimes, standing up and singing, eating a raw potato believing it to be a pear; and drinking imaginary champagne from real glasses and thereafter behaving as if intoxicated.”¹⁹⁷ Essential here is the incommensurability of a hypnotic transaction viewed externally *as spectacle*, a transaction in which domination over passivity seems implicit, and the inner or subjective reality of a psychic state which could in fact involve resistance and evasion of external authority.¹⁹⁸ Historically, the importance of public demonstrations

194. By the mid-1880s there was increasing debate about the suitability of hypnosis as a public entertainment. Note, for example, the ambivalence in this 1889 account: “Public exhibitions have called the attention of science to these states, though on the other hand the flavor of charlatanism in the matter has repelled many. For this reason it is a good thing that such public exhibitions have been forbidden in Prussia. Nothing now prevents our approaching the subject in a scientific manner. I do not wish to deprecate the services of those who have drawn attention to hypnotism by public exhibitions. Just as I refuse to join in the general condemnation of Mesmer, I try to judge men such as Hansen, Bollert and others, fairly. Though their motives may not have been purely unselfish, they have been of great service to science. . . . However, it must be added that, from the moral point of view, there is no justification for putting people in a condition which deprives them of their will for no higher object than the amusement of uncultured persons.” Albert Moll, *Hypnotism* (1889; New York: Scribner’s, 1899), pp. 391–392. A more denunciatory attitude toward traveling Mesmerists and hypnosis showmen, including a demand for legal restraint, can be seen in Georges Gilles de la Tourette, *L’hypnotisme et les états analogues au point de vue medico-legal* (Paris: E. Plon, 1887).

195. On Braid, Charcot, and Freud, see Leon Chertok and Raymond de Saussure, *The Therapeutic Revolution, from Mesmer to Freud*, trans. R. H. Ahrenfeldt (New York: Brunner/Mazel, 1979), p. 38. Hall “had been introduced to the subject [of hypnosis] in Germany by popular demonstrators claiming spiritualist powers”: Dorothy Ross, *G. Stanley Hall: The Psychologist as Prophet* (Chicago: University of Chicago Press, 1972), p. 149. Braid’s early exposure to Lafontaine’s seances is discussed in Carroy, *Hypnose, suggestion et psychologie*, pp. 91–92.

196. See Bernheim’s insistence on Hansen’s authenticity (even though he describes him as “a man unacquainted with medicine”) in *Hypnosis and Suggestion in Psychotherapy* (1884; New York: Aronson, 1973), pp. 120–121.

197. Alan Gauld, *A History of Hypnotism* (Cambridge: Cambridge University Press, 1992), p. 303. See also the account in J.-S. Morand, *Le magnétisme animal: Etude historique et critique* (Paris: Garnier, 1889), pp. 425–428.

198. For François Roustang, hypnosis is a radically other form of wakefulness that is incompatible with Western notions of consciousness. It is a wakefulness in which the loss of self-mastery, of the ability to make decisions and reflect, is a new modality of freedom. Of the thousands of characteristics of a

of “magnetization” is not whether they were staged or simulated, like some of Charcot’s exhibitions or others (evidence suggests that most were not fraudulent). Rather, they provided a set of powerful images of a hypnotic experience that defined it as an event or object from which a truth could be extracted objectively, from the outside. In the same way, various displays and representations of the “primitive” posed non-Western subjects as objects of fascination and objects susceptible to mastery and classification. The nineteenth-century exhibitions were part of a world in which people “were beginning to live as tourists or anthropologists, addressing an object-world as the endless representation of some further meaning or reality . . . but *reality*, it turns out, means that which can be represented, that which presents itself as an exhibit before an observer. The so-called real world outside is something experienced and grasped only as a series of further representations, an extended exhibition.”¹⁹⁹

Parade de cirque itself shows us another contemporary phenomenon of display and entertainment. Recent historians of art emphasize that the painting is most likely a representation of the Cirque Corvi as it was situated for several months in the fairgrounds at the Place de la Nation in 1887.²⁰⁰ To belabor this specific identity is to ignore the obvious: the thoroughness with which Seurat has abstracted specific references to any particular site into a generic image of the urban fairground and circus in the second half of the nineteenth century, a form of entertainment at the tail end of a long process of domestication and commodification. But the issue here is more than just the reification of popular culture. As some critics have insisted, carnival and popular festival did not simply disappear in the nineteenth century but rather were dispersed in various “fragmented, marginalized, sublimated, and repressed forms.”²⁰¹ In this sense, the site of *Parade de cirque* is highly

hypnotic experience, he says, some are the following: “the cohabitation or coidentity of contrary qualities, of hot and cold, of suppleness and rigidity, light and darkness, closed space and openness, hypersensibility and anesthesia, communication and closing off, concentration and relaxation, attention and distraction. An initial conclusion seems obvious: the hypnotic state has no use for the categories of space and time.” Roustang, *Influence* (Paris: Editions de Minuit, 1990), p. 84. See also the assertion that “hypnotic existence is formless,” in Jean-Luc Nancy, *The Birth to Presence*, trans. Brian Holmes (Stanford: Stanford University Press, 1993), pp. 19–23.

199. Timothy Mitchell, “The World as Exhibition,” *Comparative Studies in Society and History* 31 (1989), pp. 232–233.

200. The Cirque Corvi identification is due less to recognizable features in *Parade de cirque* than to remarks made by Gustave Kahn in his review of the work in “Peinture: Exposition des Independantes,” *Revue independante*, n.s. 7, no. 18 (April 1888), p. 161. Jean-Claude Lebensztejn insists on the irrelevance of such specificity and argues for the importance of an anonymous decontextualization in Seurat’s work, in *Chabut*, p. 31.

201. This is part of the important argument made in Peter Stallybrass and Allon White, *The Politics and Poetics of Transgression* (Ithaca: Cornell University Press, 1986), p. 178.



Hypnosis as theatrical exhibition, late 1880s.

“mixed”: on one hand it stands for the commercialization of what were once more nomadic and popular forms, but on the other it is an “enclaved environment for the controlled de-control of the emotions, where adults are given permission to behave like children again,” an arena of “ordered disorder.”²⁰² As such, *Parade de cirque* is a figuration of a social territory where techniques of fascination and attraction, of appearance and semblance, have the capacity to overpower an observer or audience, even as a psychological regression. Beginning in the late 1880s, also, fairgrounds and related spaces included new kinesthetic experiences such as ferris wheels, roller coasters, slides, and loop-the-loops. Within these “controlled” circumstances the inciting of dynamogenic bodily sensations, for example on a merry-go-round, was a fragmentary and mechanical recuperation of carnival energies.²⁰³ Needless to say, during the next decade and a half, it was on this same social terrain of the fairground that another kinematic form of visual fascination implanted itself. Cinema would radically displace survivals of premodern forms like the circus, but would also powerfully constitute itself as a related “enclave” for different modes of regression and fantasy.²⁰⁴

We can now begin to ask more specifically how the painting might be a figuration on a representational level of the very operations that it deploys (at

202. Mike Featherstone, “Postmodernism and Aestheticization,” in Scott Lash and Jonathan Friedman, eds., *Modernity and Identity* (Oxford: Blackwell, 1992), p. 284. Featherstone sees nineteenth-century fairs, music halls, spectacles and late twentieth-century tourism, theme parks, malls as related forms of “constructed otherness.”

203. See the valuable discussion on the late nineteenth-century shift from “viewing machines” to “vertigo machines” in Lieven de Caeter, “The Panoramic Ecstasy: On World Exhibitions and the Disintegration of Experience,” *Theory, Culture, and Society* 10 (November 1993), pp. 1–23. See also the account of a broad emergence of a kinesthetic material culture at the turn of the century in Hillel Schwartz, “Torque: The New Kinaesthetic of the Twentieth Century,” in Crary and Kwinter, eds., *Incorporations*, pp. 71–126.

204. The critical writings of Raymond Bellour have been important for me, in particular his outlining of interrelations between photography, hypnosis, cinema, and psychoanalysis in the nineteenth century: “These are the signs of a very strong epistemological configuration which assigned a rather new place to the subject in Western culture—a place that was increasingly linked to the formation of certain images of time, of the past and of memory. Throughout the nineteenth century, we can in fact see the gradual formation of a very important, very powerful image making tendency that became radicalized at the end of the century by two inventions which seem to have inherited, each on its own level, all of the elements that were crystallizing during those years around hypnosis, both medically and mythically. One was a mechanical invention that made possible for the first time the imaginary reproduction of movement and life; the other was a psychological theory which explained the destiny of the human subject in terms of the formation of a set of representations, of phantasies, and in terms of the subject’s attachment to certain images.” From Janet Bergstrom, “Alternation, Segmentation, Hypnosis: An Interview with Raymond Bellour,” *Camera Obscura* 3–4 (Summer 1979), p. 102. Also, Bellour’s essay on Jacques Tourneur’s masterpiece *Curse of the Demon* (1957) is a superlative meditation on cinema, hypnosis, and fascination; see Bellour, “Believing in the Cinema,” in E. Ann Kaplan, ed., *Psychoanalysis and Cinema* (New York: Routledge, 1990), pp. 98–109.

least in principle) on a molecular level through the psychomotor effects of certain chromatic and directional stimuli.²⁰⁵ I've already mentioned that one aspect of the quasi-system of dynamogeny and inhibition was its relation to hypnosis. Brown-Sequard explicitly insisted that the work of James Braid (with whom the modern study of hypnosis begins) was decisive in his own formulation of these concepts. What Braid described was the special power of the nervous system of hypnotized individuals to manifest very suddenly a heightening of motor activity in a certain localized part of the body.²⁰⁶ For Brown-Sequard, hypnosis was a major example of how dynamogenic effects inhibit large areas of an individual's functioning while only very circumscribed areas are stimulated.²⁰⁷ Hippolyte Bernheim cited Brown-Sequard's conclusion as important for his own work: "Hypnotism is then essentially only the collective effect of acts of inhibition and of dynamogeny"; and for Charles Henry hypnotism overwhelmingly demonstrated that perception was fundamentally unconscious, consisting of involuntary responses to stimuli.²⁰⁸ What is important here, and particularly in terms of Seurat's relation to these ideas, was a fundamental *indistinction* between the automatism of a hypnotized subject and the perceptual experience of a so-called "normal" subject.

The question then remains: what does it mean to read this image of audience and spectacle through the contemporary social phenomena of suggestion and somnambulism? Clearly *Parade de cirque* operates on several levels through "a bypassing of intellectual processes," such as reason and judgment, in an attentive spectator.²⁰⁹ Seurat's practice makes explicit a radical and *calculated* disparity between the rationalized construction of an image and the subrational response of its observer. Bergson, around the same time, was describing the proximity of art and hypnosis: "In the processes of art we shall find, in a weakened form, a refined and in some measure spiritualized version of the processes commonly used to induce the state of hypnosis. . . . The plastic arts obtain an effect of the

205. *Parade de cirque* is described as Seurat's "most thorough attempt to control the spectator's emotions subconsciously by the disciplined devices of his art," in Thompson, *Seurat*, p. 152.

206. James Braid, *Neurypnology, or the Rationale of Nervous Sleep Considered in Relation with Animal Magnetism* (London: J. Churchill, 1843). Brown-Sequard wrote a preface to the 1883 French edition of this work.

207. Brown-Sequard, "Dynamogenie" (1885), p. 757. The relation between dynamogeny and hypnosis is also discussed in Moll, *Hypnotism*, pp. 292–293.

208. Bernheim, *Hypnosis and Suggestion in Psychotherapy*, p. 138; and Henry, "Le contraste, le rythme, la mesure," pp 358–362.

209. Bernheim, *Hypnosis and Suggestion in Psychotherapy*, p. 137.

same kind by the fixity which they suddenly impose upon life, and which a physical contagion carries over to the attention of the spectator.”²¹⁰ In the late 1880s and 1890s many different discourses considered the ways in which external forces and procedures could influence or control both individual and collective subjects. As has been noted often, one common notion in French sociological thinkers as different from each other as Durkheim, Gabriel Tarde, and Gustave Le Bon is that the primal fact of social life is some system of control or coercion that is imposed on the individual. As discussed above, aspects of Seurat’s own practice were informed by physiological knowledge about the production of specific emotional responses. But in his last works, with their images of groups of spectators, the preoccupations with visual and chromatic mechanisms of stimulus and inhibition connect with an interest in the dynamics of social spaces in which other techniques of control could be exercised. Over a decade before Simmel published his famous essay on the metropolis and mental life, Tarde made observations about modern forms of attentiveness that are directly relevant to *Parade de cirque* and *Cirque*:

In this singular condition of intensely concentrated attention, of passive and vivid imagination, these stupefied and feverish beings inevitably yield themselves to the magical *charm* of their new environment. They believe everything that they see, and they continue in this state for a long time. It is always more fatiguing to think for oneself than to think through the minds of others. Besides, whenever a man lives in an animated environment, in a highly strung and diversified society which is constantly supplying him with fresh sights, with new books and music and with constantly renewed conversation, he gradually refrains from all intellectual effort; his mind, growing more and more stultified and, at the same time, more and more excited, becomes, as I have said, somnambulistic. Such a state of mind is characteristic of many city dwellers. The noise and movement of the streets, the display of the shop windows, and the wild unbridled rush of existence affect them like magnetic passes. Now, is not city life like a concentrated and exaggerated type of social life?²¹¹

210. Bergson, *Time and Free Will*, pp. 14–15.

211. Gabriel Tarde, *The Laus of Imitation* (1890), trans. E. C. Parsons (New York: Henry Holt, 1903), p. 84.

According to some, the audience in *Parade de cirque* has the signs of a distracted crowd, the crowd as a rootless urban phenomenon that finds itself briefly, almost by chance, before the sideshow. Certainly Seurat does not show us a group of spectators characterized by undivided attention, but at least six of these figures, whose silhouettes can be categorized as frontal, are presented fully facing the stage. Of these six possibly attentive figures, the most significant is the male figure fifth from the left. He is isolated somewhat from the rest of the crowd by his elevated position, which in turn emphasizes his rigid frontality. At the same time there is a general identity (if this can be said of figures so relentlessly characterless and generic) between this man and the musicians on the left of the stage, both in terms of dress and posture. It's possible to read this figure as immobile and deeply absorbed, as if in the grip of a silent private communion, as if some initiate in league with his counterparts on stage.²¹² It is a figure who imparts a sense of being elect even in the midst of urban anonymity, even a figuration of what Mikkel Borch-Jacobsen unsparingly describes as “homo democraticus or ‘man without qualities,’ without his own identity, brutally revealed by the retreat of the great transcendent political and religious systems, who is no longer a subject . . . the deeply panicked, de-individualized, suggestible, hypnotizable being of the lonely crowd.”²¹³ If such a reading of this figure is tenable, then there is no reason why it might not also apply to other adjacent members of the crowd, say the woman with the tall hat fourth from the right or even the man shown in profile in the bottom left corner.

But at the same time it's entirely possible to read the relation between this figure and the musicians as one of “imitation,” as this concept was developed in the work of Tarde in the 1880s. Tarde, as we know, posed a very different explanatory scheme for the understanding of social cohesion from that of Durkheim. At the heart of his work was the notion that “society could not exist or change or advance a single step unless it possessed an untold store of blind routine and slavish

212. In this sense, a new modernizing instrumentality is fulfilling here (at least superficially) the same functions that Michael Fried identified as part of anti-rococo French painting: “A painting, it was claimed, had first to attract (*attirer*, *appeller*) and then to arrest (*arreter*) and finally to enthrall (*attacher*) the beholder, that is, a painting had to call to someone, bring him to a halt in front of itself, and hold him there as if spellbound and unable to move.” Fried, *Absorption and Theatricality: Painting and Beholder in the Age of Diderot* (Berkeley: University of California Press, 1980), p. 92.

213. Mikkel Borch-Jacobsen, *The Emotional Tie: Psychoanalysis, Mimesis, and Affect* (Stanford: Stanford University Press, 1992), p. 26. Robert Herbert associates this figure with the visual types that were later to populate the paintings of Magritte, in his “Parade de cirque” de Seurat et l'esthétique scientifique de Charles Henry,” p. 18. See also the related discussion in Paul Smith, *Seurat and the Avant-Garde*, pp. 124–125.

imitation which was constantly being added to by successive generations.”²¹⁴ “Social self-organization” was propagated, according to Tarde, not by laws or civic institutions but by processes of imitative repetition: “society may be defined as a group of beings who are apt to imitate one another.”²¹⁵ The engine of this “social mystery” of imitation was, at a molecular level, the influence of one person on another, that is, the phenomenon of suggestion. Tarde unhesitatingly equated social existence with somnambulism, that is, with a state characterized by heightened receptivity to suggestion. Le Bon and others noted hypnotic aspects of the life of crowds, but Tarde went much further: “I shall not seem fanciful in thinking of social man as a veritable somnambulist. . . . The social, like the hypnotic state, is only a form of a dream.”²¹⁶ He details the historical development of different regimes of imitation and suggestion, from despotic authority which operated through effects of prestige, what he called “la suggestion prestigeuse,” to modern societies in which the operations of conformity and suggestion have multiplied and dispersed far beyond the single circuit of charismatic ruler and docile subject.²¹⁷ New media and means of mass communication were central to his investigations.²¹⁸

Tarde was constantly identifying functional parallels between individual subjective behavior and the actions of large social collectivities, but one of his most suggestive analogies was visual. He invoked Helmholtz’s account of entoptical phenomena to indicate how an individual was fundamentally inattentive to an enormous amount of sensory experience: “At each instant we are assailed and troubled by ocular sensations such as the *mouches volantes*, which if we always noticed them, if our ego [moi] received them into consciousness [elite], would prevent any judgment of location or systematic organization of retinal impressions.”²¹⁹ We also never hear the low-level buzzing that is continually in our ears, nor are usually aware that we are continually traversed by sensations of all kinds. Social consciousness, he insists, is much the same: it operates according to a related principle of narrowed attentiveness and exclusion, through which a vast amount of

214. Tarde, *The Laws of Imitation*, p. 75. The sections of this book I have cited were published in periodical form in 1884.

215. Tarde, *The Laws of Imitation*, p. 68.

216. *Ibid.*, pp. 76–77.

217. Gabriel Tarde, “Categories logiques et institutions sociales,” *Revue philosophique* 28 (August 1889), p. 123.

218. See Serge Moscovici, *The Age of the Crowd: A Historical Treatise on Mass Psychology*, trans. J. C. Whitehouse (Cambridge: Cambridge University Press, 1985), p. 158. One of Tarde’s basic arguments was “the primacy of the means of communication over all the instruments of social life.”

219. Tarde, “Categories logiques et institutions sociales,” p. 302.

social inventions, memories, discoveries fall into oblivion as they disappear from the foyer of “the social retina.”²²⁰

Tarde’s phrase is appropriate for *Parade de cirque*, where there is an overlapping of an individual physiological retina and a social one. Take, for example, the relation between the aforementioned attentive figure and the four musicians at the left: it is not simply a connection between audience and performers in which the latter are observed by the former. Rather it’s possible to read an *imitative* relation there as well: the outline of a simple mechanism of social conformity. Various imitative relations, for Tarde, were at the heart of social cohesion, relations founded on an innate tendency to mimicry in the nervous system. He sometimes called it “intercerebration,” to describe the relation between two brains “one of which fascinates the other”; “this relation consists of a special polarisation in the latter of the belief and desire which are stored up in each of its elements.”²²¹ One can examine other features of *Parade de cirque* for related operations of this “social retina,” such as the row of spectators at the bottom: the line of heads diagrams the diffuse nature of imitative social mechanisms, what Tarde called “fashion-suggestibility.” By this he meant to describe how half-conscious observation and mere physical proximity produce (even within the obvious diversity of this assemblage) a *functional* social homogeneity, indicated here by the looks exchanged by members of the crowd and by the redundancy of a limited number of hat styles, hairstyles, not to mention a loosely shared absorption in the spectacle.²²² At issue is how modern social cohesion was essentially a kind of mental cohesion resulting from countless “contagion-like” processes of transmission, for Tarde proposed the notion “that the progress of civilization renders subjection to imitation at once more personal and more rational.”²²³ This might also provide a way of reading the puzzling treatment of the audience in *Cirque* a few years later: the reductive, almost cartoonlike depiction of this audience may have been a way of sardonically revealing processes of imitation and mimicry that operate both within and beyond the distinctions of social class.²²⁴ It has long been noted that these figures are built

220. Ibid., p. 303.

221. Tarde, *The Laws of Imitation*, p. 88.

222. For an extended discussion of Tarde and the emergence of consumerism, see Rosalind Williams, *Dream Worlds: Mass Consumption in Late Nineteenth Century France* (Berkeley: University of California Press, 1982), pp. 342–384.

223. Tarde, *The Laws of Imitation*, p. 83.

224. “So-called popular wishes, the aspirations of a small town, for example, or of a single class, are composed exclusively, at a given moment, of tendencies . . . to ape in all particulars some richer town or some superior class. This body of simian proclivities constitutes the potential energy of a society.” Ibid., pp. 106–107.

up out of dynamogenic elements (the diagonals and V shapes of hair, clothing, eyes, moustaches): that is, Seurat has embedded into his representation of the crowd his own mechanisms for the production of “contagious” emotional effects. At the same time, the vertical layering of these seated spectators according to social class in *Cirque* might be similar to what Tarde called “terraces of consecutive magnetisations.” “If every society stands forth as a hierarchy,” he wrote, “it is because every society reveals the terracing of which I have just spoken, and to which, in order to be stable, its hierarchy must correspond.”²²⁵ Yet if in both *Cirque* and *Parade de cirque* there is an indication of a diffuse and reciprocal suggestibility operating within the crowd, both paintings also depend on the symbolic presence of a central, perhaps controlling figure, perhaps a “grand magnetiseur,” who would, according to Tarde, occasionally make an appearance within modern society. Tarde clearly believed in such “atavistic phenomena,” that is, the collective survival of archaic forms of social behavior, and that modern individuals were deluded to think themselves immune to the oldest “effects of obedience and imitation through fascination. Is not fascination,” he asks, “a genuine neurosis, a kind of unconscious polarization of love and faith?”²²⁶ Attention, Tarde had written, was fundamentally disconnected from an empirical act of vision, and instead he defined it as the transformation of sensation by effort and desire: attention “is the desire for an increase in present belief.”²²⁷

225. Tarde, *The Laws of Imitation*, pp. 84–85. The mixture of social and geological metaphors is one of the many reasons why Deleuze and Guattari championed Tarde in their *A Thousand Plateaus*, pp. 218–219. For these authors, Tarde was the inventor of microsociology, who, unlike Durkheim, “was interested instead in the world of detail, or the infinitesimal: the little imitations, oppositions, and inventions constituting an entire realm of subrepresentative matter.” Tarde, for whom “molecular” is a key term, understood that “beliefs and desires are the basis of every society, because they are flows and as such are ‘quantifiable’; they are veritable social Quantities, whereas sensations are qualitative and representations are simple resultants.” Oddly, in spite of their partisanship on his behalf, Deleuze and Guattari do not, to my knowledge, seem ever to have identified Tarde as one of the sources for their concept of the “plateau” (which they affiliate with the work of Bateson). Tarde uses “plateau” as a flexible figure for natural, social, and statistical processes and events, including the operation of “social desire.” See *The Laws of Imitation*, pp. 116–127.

226. Tarde, *The Laws of Imitation*, p. 80.

227. Gabriel Tarde, “Belief and Desire,” in *On Communication and Social Influence: Selected Papers of Gabriel Tarde*, ed. Terry N. Clark (Chicago: University of Chicago Press, 1969), pp. 197–198. This essay was originally published in *Revue philosophique* in 1880. In it Tarde suggests some of the epistemological problems that were to become crucial in Seurat’s work: “More important than making a definition of this type is to note that belief, no more than desire, is neither logically nor psychologically subsequent to sensation; that, far from arising out of an aggregate of sensations, belief is indispensable both to their formation and their arrangement; that no one knows what remains of sensation once judgment is removed; and that in the most elementary sound, in the most indivisible colored point, there is already a duration and a succession, a multiplicity of points and contiguous moments *whose integration is an enigma.*” (Ibid.; emphasis added.)

Le Bon's *La psychologie des foules* (1895) became the best known of a large body of work on crowd psychology in the late 1880s and 1890s, and it has been discussed at length by many commentators.²²⁸ Less frequently noted, however, is the way in which Le Bon portrays the crowd as a particular modality of perception, as a specific social arrangement that conditions the limits of perceptual experience. This interest in the boundaries of human perception was also part of his later amateurish investigation of X rays and other forms of radiation outside the visible wavelengths of the spectrum.²²⁹ Writing in the early 1890s, Le Bon posed the modern crowd as a viewing machine, capable of generating "collective hallucinations," either through its internal actions or at the prompting of an external manipulator. The crowd in Le Bon is a generalized site on which the accumulated dread and hope associated in the nineteenth century with social insurrection collapse into an abstract contentless mass onto which dream imagery of any sort can be projected. He reconceives the crowd as a place for the consumption of illusion.

One of the characteristics of the crowd, according to Le Bon, is that once an individual is subsumed in it, he or she becomes "incapable of observation . . . the faculty of seeing becomes destroyed."²³⁰ But he insists at the same time that a crowd "thinks in images. . . . It accepts as real the images evoked in its mind, though they most often have only a very distant relation with the observed fact."²³¹ Le Bon the political thinker intuits the essence of modern spectacular culture, which Guy Debord was to articulate seven decades later: "wherever representation takes on an independent existence, the spectacle reestablishes its rule."²³² For Le Bon "observation" refers to a cognitive model predicated on a workable notion of objective reality, essentially a classical epistemological model but one that begins to corrode within a field saturated by illusion, hallucination, and whole industries of simulation. Le Bon also proposes a flexible and far from literal notion of what

228. On earlier lesser-known studies on crowd psychology see Jaap van Ginneken, "The 1895 Debate on the Origins of Crowd Psychology," *Journal of the History of the Behavioral Sciences* 21 (October 1985), pp. 375–382.

229. See Mary Jo Nye, "Gustave Le Bon's Black Light: A Study in Physics and Philosophy in France at the Turn of the Century," *Historical Studies in the Physical Sciences*, ed. Russell McCormach, vol. 4 (Princeton: Princeton University Press, 1974), pp. 163–196. This article discusses, among other things, Le Bon's early medical training, his contentious exchanges with the Lumiere brothers, and his correspondence with Albert Einstein in the 1920s.

230. Gustave Le Bon, *The Crowd* (1895; New York: Viking, 1960), pp. 42–43.

231. *Ibid.*, p. 41.

232. "For one to whom the real world becomes real images, mere images are transformed into real beings—tangible figments which are the efficient motor of trancelike behavior." Guy Debord, *The Society of the Spectacle*, trans. Donald Nicholson-Smith (New York: Zone Books, 1994), p. 17.

constitutes a crowd. His concern is not the physical accumulation of large numbers of people in a single place but rather aggregations of people who in fact may occupy spatially remote locations but nonetheless constitute an effective *psychological* unity. His “law of the mental unity of crowds” certainly anticipates the collectivities that will be conjured up by all the telecommunicative and televisual apparatuses of the twentieth century. Le Bon writes that “thousands of isolated individuals may acquire at certain moments, and under the influence of certain violent emotions—such as a great national event—the characteristics of a psychological crowd.”²³³ But, he continues: “At certain moments half a dozen men might constitute a psychological crowd,” an observation clearly useful to an analysis of Seurat’s *Parade de cirque*. Le Bon reinvents the idea of the crowd as a way of identifying and accounting for new forms of social composition and, in contrast to Durkheim, indicating how unstable and potentially dangerous social aggregates are held together in order to manage them.²³⁴

Most significantly Le Bon emphasizes that a crowd, by definition, is “in a state of expectant attention, which renders suggestion easy.”²³⁵ Le Bon acknowledges here, as did many researchers during the late nineteenth century, the uncertain and fluid relation between hypnosis and attention. Important and unprecedented is the assumption that attention has no necessary connection to objective optical observation of the world, that attention can subsist outside of what Le Bon calls the faculty of seeing. Le Bon was an influential part of a tradition of crowd psychology that deployed an explanatory model of “regression,” that saw in the crowd a drift toward a more primitive order of consciousness, a shift to “lower” cerebral functions, analogous to infantilism or savagery. Part of this process is the withdrawal of one’s attention from one’s surrounding environment and its refocusing on some real or symbolic figure (for Le Bon and later for Freud, the charismatic figure of the leader or chief) with whom the individual establishes a fundamental

233. Le Bon, *The Crowd*, p. 24.

234. It should be noted that Le Bon’s notion of the crowd is remote from Durkheim’s ideas about social aggregates. Le Bon saw the crowd as an example of how groups could become completely detached from the social substrate of morality and cultural practices, which Durkheim felt were still present even in crowd situations. On the crowd in Durkheim, Tarde, and Le Bon, see Charles Lindholm, *Charisma* (Oxford: Blackwell, 1990), pp. 27–49. See also Catherine Rouvier, *Les idées politiques de Gustave Le Bon* (Paris: Presses universitaires de France, 1986), pp. 100–102; Susanna Barrows, *Distorting Mirrors: Visions of the Crowd in Late Nineteenth Century France* (New Haven: Yale University Press, 1981), pp. 162–188; and Patrick Brantlinger, *Bread and Circuses: Theories of Mass Culture as Social Decay* (Ithaca: Cornell University Press, 1983), pp. 154–183.

235. Le Bon, *The Crowd*, p. 39.

rapport (or surrender).²³⁶ But in the context of multiplying forms of spectacle in the 1890s, including early cinematic experience, it is interesting to consider Le Bon's identification of a theatrical configuration as the most powerful means for controlling a crowd: "Nothing has a greater effect on the imagination of crowds of every category than theatrical representations. The entire audience experiences at the same time the same emotions."²³⁷ Nietzsche had already made a related observation about the nature of a modern audience: "No one brings his finest senses of art to the theater, nor does the artist who works for the theater. . . . There the most personal conscience is vanquished by the leveling magic of the great number; there, stupidity has the effect of lasciviousness and contagion; the neighbor reigns, one becomes a mere neighbor."²³⁸ Le Bon's text, then, is merely one indication of how the image of theater exceeded its older place within models of mimetic relations and was used as spatial figure for new effects of subjectification. Seurat's paintings, too, use the notion of theater as a figure that can describe both collective public experiences, such as ones literally depicted in his paintings, and also individuated experiences produced by the management of perception in terms of a solitary subject.



Perhaps the most significant cultural phenomenon in the second half of the nineteenth century where problems of theater, spectacle, and techniques of psychological control come together is in the operatic work of Richard Wagner.²³⁹ Even after his death in 1883, Wagner's aesthetic legacy was inseparable from problems of both perceptual attentiveness and social cohesion.²⁴⁰ For any artist at that

236. Freud's extended discussion of Le Bon's "brilliant" and "deservedly famous" work is in his *Group Psychology and the Analysis of the Ego* (1921), trans. James Strachey (New York: Norton, 1959), p. 12: "And, finally, groups have never thirsted after truth. They demand illusions, and cannot do without them. They constantly give what is unreal precedence over what is real; they are almost as strongly influenced by what is untrue as by what is true."

237. Le Bon, *The Crowd*, p. 68.

238. Friedrich Nietzsche, *The Gay Science* (1882), trans. Walter Kaufmann (New York: Vintage, 1974), p. 326 (sec. 368). Nietzsche elsewhere remarked, "Our entire sociology does not know any other instinct than that of the herd, i.e., that of *the sum of zeroes*—where every zero has 'equal rights,' where it is virtuous to be zero." *The Will to Power*, p. 33 (sec. 53); emphasis in original.

239. The precise nature of Seurat's clear interest in Wagner's work has been a matter of much speculation. He associated with some of the most prominent Wagnerians in Paris, including the principals behind the *Revue wagnerienne*, which was published between 1885 and 1888. For accounts of Seurat's relation to contemporary Wagnerism, see Zimmermann, *Seurat and the Art Theory of His Time*, pp. 307–311, and Smith, *Seurat and the Avant-Garde*, pp. 123–140.

240. The indispensable work on Wagner and mass culture is Theodor W. Adorno, *In Search of Wagner*, trans. Rodney Livingstone (London: Verso, 1981). See also the valuable discussion in Andreas Huyssen, "Adorno in Reverse: From Hollywood to Richard Wagner," in *After the Great Divide: Modernism, Mass*

time, whether visual or literary, Wagner's work itself, as well as the extravagant claims that were being made on its behalf, posed what Mallarmé called a "singular challenge." Not only did the example of Wagner put in question the priority of the individual arts of poetry and visual representation, but it suggested the outlines of a collective cultural experience that Wagner himself compared with festival theater in Greek antiquity. Beginning in the 1840s and evolving confusedly for the rest of his life, Wagner's social critique had nothing particularly original about it within a broader field of nineteenth-century indictments of the effects of social and economic modernization. What remains singular about Wagner was the relative specificity of his cultural program for social reintegration and his belief in the transformative effects of the *collective* experience of music drama performed and produced as a ritual communal event.²⁴¹ In connection with the problems of social aggregates and solidarities in Durkheim and Seurat, it is important to understand how much Wagner's work was linked to the problem of community formation, of welding individuals into a social unity, by imposing a uniform mode of perception and response, even if it was in terms of *volksish* homogeneity.²⁴² As Marc Weiner has argued, vision had an extraordinary primacy for Wagner. Opera, emulating Greek tragedy, was for him a mirror in which a community could see itself reflected. "The optical metaphor of the theatrical experience is thus based upon the notion that the sense of vision serves to reinforce one's place within the social whole."²⁴³

By the middle of the century Wagner had already framed part of his cultural critique around the issues of attention and distraction. Prefiguring some early twentieth-century debates about the effects of mass culture which articulated distraction as a term opposed to a self-conscious contemplative perception, Wagner deplored the pervasiveness of distracted modes of cultural consumption.²⁴⁴ In the

Culture, Postmodernism (Bloomington: Indiana University Press, 1986), pp. 16–43; and Friedrich Kittler, "World Breath: On Wagner's Media Technology," in David J. Levin, ed., *Opera through Other Eyes* (Stanford: Stanford University Press, 1994), pp. 215–235.

241. One of Wagner's exemplary explanations of the degradation of contemporary theater and opera in terms of their disconnection from the life of a community is contained in "A Theater at Zurich" (1851), in *Judaism in Music and Other Essays*, pp. 25–57. The persistence of these Wagnerian social ambitions is described in the context of Gustav Mahler's circle in 1890s Vienna in William J. McGrath, *Dionysian Art and Populist Politics in Austria* (New Haven: Yale University Press, 1974), pp. 120–164.

242. For an important discussion of the problem of community formation in Wagner, see David J. Levin, "Reading Beckmesser Reading: Antisemitism and Aesthetic Practice in *The Mastersingers of Nuremberg*," *New German Critique* 69 (Fall 1996), pp. 127–146.

243. Marc Weiner, *Richard Wagner and the Anti-Semitic Imagination* (Lincoln: University of Nebraska Press, 1995), p. 36.

244. See, for example, Wagner's remarks on receptiveness and distraction in "Public and Popularity," in *Religion and Art*, trans. W. Ashton Ellis (Lincoln: University of Nebraska Press, 1994), pp. 62–64.

context of music he made a distinction between “higher” (deeply attentive) and “lower” (distracted) forms of listening and clearly advocated the former as purified and ethically superior perceptual engagement. His critique of French and especially Italian opera noted how works were composed around a few brilliant arias that would attract an audience’s attention for their brief duration, while for the balance of the performance this attention was distracted or engaged elsewhere. Wagner’s conception of a German opera postulated an audience capable of sustained and *continuous* attention through an entire performance.²⁴⁵ More specifically, one of Wagner’s frustrations with the experience of grand opera and theater in the mid-nineteenth century was the problem of spectators who were given multiple points of attraction.²⁴⁶ He was dissatisfied with traditional theater design, which had long allowed (or encouraged) audiences to look at each other, at the orchestra, at the diverse social texture of the theater (which was the case with the variety-show formats of early cinema as well).²⁴⁷ The physical plan of Bayreuth was, in part, the outcome of Wagner’s desire to exercise a fuller control over the

245. Richard Wagner, “Zukunftsmusik” (1861), in *Judaism in Music and Other Essays*, p. 332: “In the Opera-house of Italy there gathered an audience which passed its evenings in amusement; part of this amusement was formed by the music sung upon the stage, to which one listened from time to time in pauses of the conversation; during the conversation and visits paid from box to box the music still went on, with the same office one assigns to table music at grand dinners. . . . An opera must contain at least *one* aria to which one is glad to listen; if it is to have a success, the conversation must be broken, and the music listened to with interest, at least six times; whilst the composer who is clever enough to attract the audience’s attention a whole twelve times, is lauded as an inexhaustible melodic genius.” See also Wagner, *Opera and Drama*, trans. W. Ashton Ellis (Lincoln: University of Nebraska Press, 1995), pp. 128–129, where Wagner insists on the necessity of spectators who will give “continuous and undivided attention to a fascinating subject.”

246. Wagner’s critique was preceded by Schopenhauer’s even more thorough dismissal of nineteenth-century opera as a form synonymous with distraction: “Indeed, to be properly interpreted and enjoyed, the highest productions of music demand the wholly undivided and undistracted attention of the mind so that it may surrender itself to, and become absorbed in, them in order thoroughly to understand its incredibly profound and intimate language. Instead of this, the mind during highly complicated opera music is at the same time acted on through the eye by the means of the most variegated display and magnificence, the most fantastic pictures and images, and the most vivid impressions of light and color; moreover, it is occupied with the plot of the piece. Through all this it is diverted, distracted and deadened, and thus rendered as little susceptible as possible to the sacred, mysterious and profound language of tones.” Schopenhauer, *Parerga and Paralipomena* (1851), vol. 2, trans. E. F. J. Payne (Oxford: Clarendon Press, 1974), p. 432.

247. See the historical account of the behavior of French operatic audiences in the nineteenth century in James H. Johnson, *Listening in Paris: A Cultural History* (Berkeley: University of California Press, 1995). Johnson details the many factors that gradually led to an etiquette of relative silence in the opera house, to “ever more restrained and outwardly attentive audiences,” to the idea of “an attentive, absorbed public,” which would have been unthinkable in the eighteenth century. See also the broader discussion of the remaking of spectator conduct during the nineteenth century in Richard Sennett, *The Fall of Public Man: On the Social Psychology of Capitalism* (New York: Random House, 1978), pp. 205–218.

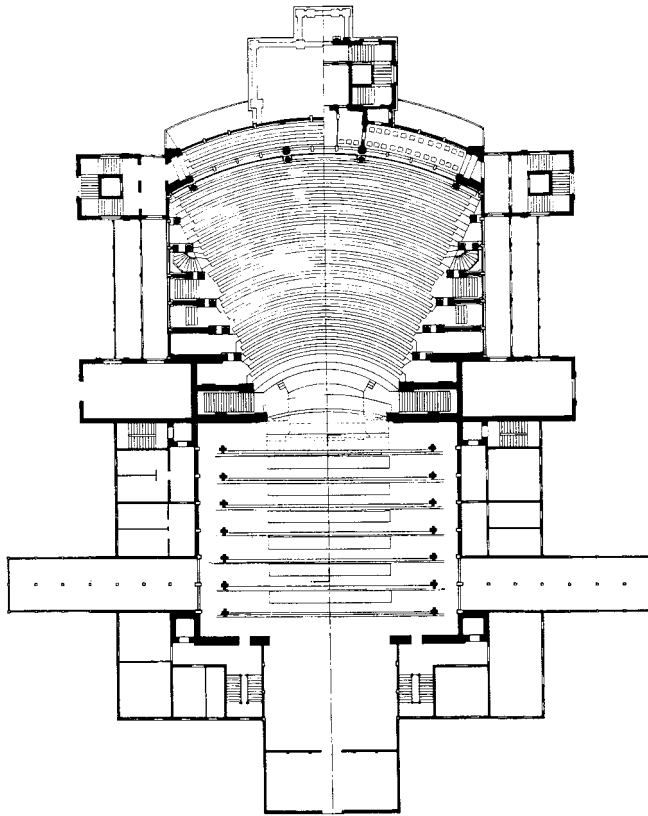

*Ground plan of
Festspielhaus at
Bayreuth, 1876.*

attentiveness of an audience, to subordinate it to the will of the artist and to generate a collective state of reception worthy of an art with such social aspirations.²⁴⁸

One of Wagner's "reforms," incarnated in the design of Bayreuth, involved the transformation of the nineteenth-century theater into a construction of visibility that more rigorously structured the spectator's perceptual experience. His aim was

248. Max Nordau, for whom Wagner was the foremost incarnation of degeneracy, denounced the composer for his subversion of traditional notions of attentiveness. He complains that Wagner's "unending melody" is a "product of degenerate thought; it is musical mysticism. It is the form in which incapacity for attention shows itself in music. In painting, attention leads to composition; the absence of it to a uniformly photographic treatment of the whole field of vision as with the Pre-Raphaelites. . . . In music, attention expresses itself in completed forms, i.e. in well-defined melodies; its absence, on the contrary, shows itself by the dissolution of form, the obliteration of its boundary lines, and thus by unending melodies as with Wagner." Nordau, *Degeneration*, p. 199. See also Nietzsche's association of decadence and "the deterioration of the melodic," in *Selected Letters of Friedrich Nietzsche*, ed. Christopher Middleton (Chicago: University of Chicago Press, 1969), p. 233.

to establish a “theatron,” a “place for seeing,” and it was through the collective act of seeing that the semblance of a community would come into being.²⁴⁹ First Wagner completely eliminated the lateral views of older theater design to achieve a frontal engagement with the stage for every spectator. He also initiated the idea of near-complete darkness as a way of heightening the intensity of lighting effects on stage and preventing peripheral distraction. The multiplication of proscenium arches combined with the extreme darkness of the theater was intended to detach the illuminated stage from any legible relation to the rest of the opera house. Wagner’s insistence on lowering the orchestra out of sight is another part of the phantasmagoric character of his work, discussed by Theodor Adorno and others, where “phantasmagoric” designates the systematic concealing and mystification of the processes of production. By making the orchestra invisible, Wagner made the source of the music unidentifiable and hence mystified.²⁵⁰

It is important not to completely separate these elements of Wagner’s illusion-making from a larger nineteenth-century history of visual display. For example, the lantern projections for the first performances of *Das Rheingold* in 1876 come out of a long tradition of magical and popular entertainment that had been widespread for decades. Wagner disdainfully looked on the diorama and panorama as the mass forms of verisimilitude he sought to avoid in his productions, but these were the kind of popular attractions with which he would have felt himself in competition. For the diorama, at its peak of popularity in the late 1830s and early 1840s, operates according to principles not unrelated to the effects produced subsequently at Bayreuth. In particular, the experience of the diorama (coming as it did out of Daguerre’s successful work as a theatrical designer) was based on a

249. In Wagner’s own words, the primary illusion at Bayreuth “is created by the fact that the spectators think that what is happening on the stage is far away, while they perceive it with all the clarity of actual proximity; this gives rise to a further illusion, namely that the people appearing on stage are of superhuman stature. The success of this arrangement alone should be enough to give some idea of the incomparable effect of the relationship thus created between spectator and stage. As soon as the spectators are sitting in their seats, they find themselves in a virtual ‘theatron,’ that is, a space designed solely for looking at what can be seen from its seats. Between the spectators and the scene to be observed nothing is clearly visible; there is only a ‘space,’ kept indeterminate by architectural mediation, between the two prosceniums, presenting the distanced image in all the inaccessibility of a dream vision.” Wagner, *Gesammelte Schriften und Briefe*, ed. Julius Kapp, vol. 12 (Leipzig: Hesse und Becker, 1914), p. 291, cited in Schivelbusch, *Disenchanted Night*, p. 219. In this text Schivelbusch discusses the similarities between effects produced at Bayreuth and Daguerre’s diorama from the 1820s.

250. The details of Wagner’s practical remaking of theatrical experience are available in many places. One valuable account, because of its focus on the continuity of Wagner’s work with cinema, is Jo Leslie Collier, *From Wagner to Murnau: The Transposition from Stage to Screen* (Ann Arbor: UMI Research Press, 1988), pp. 9–34. Adorno’s chapter on “Phantasmagoria” in his *In Search of Wagner* remains essential; see also note 270 below.

similar disruption of an intelligible relation of distance between viewer and illusory scene. Numerous firsthand accounts stressed the visual disorientation that confounded conventional pictorial cues about the relative proximity of near and far objects. The diorama also commanded visual attention through the disjunction between its illuminated imagery and the darkened space of the spectator. Despite his archaizing surfaces, Wagner stands for a will to mastery over all aspects of spectacle that would allow for the calculated production of states of regression, fascination, dream—the very attentiveness that would belong to cinema half a century later, with the introduction of synchronized sound. Nonetheless, Wagner's control over emotional response was effective enough to provoke Nietzsche's remark that Wagner furnished "the first example, only too insidious, only too successful, of hypnotism by means of music . . . persuasion by the nerves."²⁵¹ According to Nietzsche, it was a specifically modern "counterfeiting of transcendence."²⁵²

Soon after the first performances at Bayreuth, Wagner's concrete remaking of the spectator's experience was noted by French critics.²⁵³ Eugene Veron in 1878 wrote that Wagner disposed everything "in such a way that the spectator would be exclusively preoccupied with the spectacle and could not be distracted by foreign impressions . . . and nothing could divert their attention from the point on which it should be concentrated." It was, he maintained, the production of a dreamlike clairvoyance, unlike normal waking states.²⁵⁴ A decade later such assessments of

251. Nietzsche, *The Case of Wagner*, p. 171.

252. *Ibid.*, p. 183.

253. On Wagnerism in France, see the invaluable *Wagner et la France*, ed. Martine Kahane and Nicole Wild (Paris: Editions Herscher, 1983). See also Isabelle Wyzewska, *La Revue wagnerienne: Essai sur l'interprétation esthétique de Wagner en France* (Paris: Librairie Académique Perrin, 1934); Gerald D. Turbow, "Art and Politics: Wagnerism in France," in David C. Large and William Weber, eds., *Wagnerism in European Culture and Politics* (Ithaca: Cornell University Press, 1984), pp. 134–166; Christian Goubault, "Modernisme et décadence: Wagner et anti-Wagner à la musique française de fin de siècle," *Revue internationale de musique française* 18 (November 1985), pp. 29–46; Richard Sieburth, "1885, February: The Music of the Future," in Denis Hollier, ed., *A New History of French Literature* (Cambridge: Harvard University Press, 1989), pp. 789–797; Erwin Koppen, "Wagnerism as Concept and Phenomenon," in Ulrich Müller and Peter Wapnewski, eds., *Wagner Handbook* (Cambridge: Harvard University Press, 1992), pp. 343–353; L. J. Rather, *Reading Wagner: A Study in the History of Ideas* (Baton Rouge: Louisiana State University Press, 1990), pp. 59–77; and Elaine Brody, *Paris: The Musical Kaleidoscope, 1870–1925* (New York: Braziller, 1987), pp. 21–59. An entertaining account of the *Revue wagnerienne* is presented in Jacques Barzun, *Darwin, Marx and Wagner: Critique of a Heritage*, 2d ed. (New York: Doubleday, 1958), pp. 288–293. Also important is the discussion of Wagner in Jane Fulcher, *The Nation's Image: French Grand Opera as Politics and Politicized Art* (Cambridge: Cambridge University Press, 1988), including her reading of a Wagnerian subtext in Manet's 1862 painting *Music in the Tuileries*.

254. Veron, *L'esthétique*, p. 395.

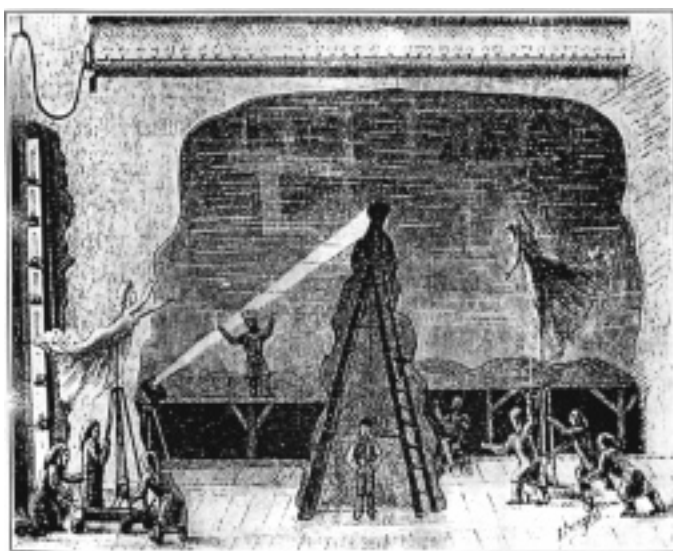

Rhinemaidens in Wagner's Das Rheingold: as seen by the Bayreuth audience and from backstage, late 1870s.

Wagner's attentional strategies were pervasive. In the March 1887 issue of the *Revue wagnérienne* a laudatory article by Charles and Pierre Bonnier astutely described Wagner's measures at Bayreuth for controlling attention and for provoking "the fullest possible perception." Notably, they insisted that the visual effects were more significant than acoustical ones.²⁵⁵ According to these writers, the basis of Wagner's "optics" begins with "doing away with the autonomy of the audience" by "absorbing and dominating it." They detail an approach that certainly confirms Nietzsche's reading of Wagner as a "master of hypnotic tricks": a means of "isolating attention and fixing the gaze" in order to impose the theatrical illusion more fully and intensify the effects of the music. Wagner's effects are in part achieved through a process of optical disorientation that disrupts conventional theatrical

255. Charles and Pierre Bonnier, "Documents et critique expérimentale: Parsifal," *Revue wagnérienne* 2 (March 1887), pp. 42–55. A year earlier, a related assessment was made in terms of the specific expectations of French audiences: "At Bayreuth, for the spectator plunged in darkness, all effects have a redoubled intensity, effects of daylight more brilliant, of night even blacker, and electric light more supernatural. If for us French, the theater is a place of pleasure, where everything is a distraction, where the gratification of seeing the opera is no greater than the pleasure of being seen oneself, this German system will seem shocking to us at first." Albert Soubies and Charles Malherbes, *L'oeuvre dramatique de Richard Wagner* (Paris: Fischbacher, 1886), p. 290.

space. Detailing the well-known features that produced Wagner's "mystic abyss"—the multiplication of proscenium arches, the convex curvature of the "roof" concealing the orchestra, and the darkness of the theater—the Bonniers describe a breakdown of standard perspectival expectations so that there is no rationalizable or metric relation between the position of a spectator and the events on stage. It is a calculated confusing of the distance separating the viewer from the spectacle, with the result of making figures seem larger than life and producing other distortions of scale.²⁵⁶ This dissociation between stage and audience is further enhanced by the extreme contrast between the brightness of the stage and the darkness of the rest of the theater, which make the stage seem like "a luminous detached rectangle." This isolated zone of brightness, they insist, produces a *fixation* of the eyes on the same points throughout, and the gaze of the viewer can be "easily dominated." The overall organization of this "theatrical apparatus," they conclude, "compels attention and controls sensorial perception."

A few years later, the art theorist Paul Souriau noted the "absolute illusion" produced by the invisibility of the orchestra at Bayreuth, and noted that the inability to localize the origin of musical sounds enhanced their magical and hypnotic effects.²⁵⁷ Souriau was one of the first critics to characterize Wagner's work specifically as "phantasmagoric," as situated in a lineage not only of opera and musical practice but also of illusion and suggestion, beginning with late eighteenth-century phantasmagoric displays and spectacles. At the same time, writing near the threshold of cinema's emergence, he foresees how the effects of Wagner's work have unrealized possibilities of technological expression:

The phantasmagoria ought to take its place in the rank of the arts, as one of the most suggestive of the arts. How often in listening to music we have images before our eyes as objects of contemplation, but they are light, mobile, almost immaterial images, having only a shadow of reality, as if they are the luminous projection of our reveries produced by the music. Perhaps a new Wagner will soon write an opera for the magic lantern—an opera of dreamlike music and fantastic and virtually imaginary tableaux.²⁵⁸

256. Nietzsche seems to have understood this Wagnerian illusion of increased size: "Ah, this old magician. How much he has imposed on us. The first thing his art offers us is a magnifying glass: one looks through it, one does not trust one's eyes, everything looks big." *The Case of Wagner*, p. 160.

257. Paul Souriau, *La suggestion dans l'art* (Paris: Felix Alcan, 1893), pp. 176–177.

258. *Ibid.*, p. 59.

Finally this leads us back to Seurat, who was well aware of this dimension of Wagner's practice, either through articles such as this one or from his friends who had been to Bayreuth.²⁵⁹ But what is most extraordinary is that Seurat, knowing of these explicitly theatrical effects, sought to emulate them in a radically different medium, by producing a related impression with the painted framing on the borders of his large canvases. His friend Emile Verhaeren wrote: "Seurat reflected on how at Bayreuth the theater was completely darkened before presenting the stage bathed in light as the solitary center of attention. The idea of this kind of stark contrast between brightness and darkness led him to adopt more somber frames, even while maintaining his practice of doing them in complementaries."²⁶⁰ This confirms not only that Seurat thought in terms of managing attention but that he was able to find models for his own practice in cultural arenas other than the visual arts, specifically in the visual and theatrical dimensions of Wagner's operas. And it is evidence of the weight of Wagner's reputation during these years that even indirect verbal accounts of the experience of Bayreuth could have had such an effect.²⁶¹

Seurat's relation to Wagner, like that of Mallarmé, was profoundly mixed. (Mallarmé also had little firsthand experience of Wagner's work yet produced one of the most important critical responses to it). While Seurat was clearly interested in many possible techniques of controlling and managing subjective response, his last major paintings are decisive subversions of the representational pretenses of any forms of verisimilitude, whether of Salon painting, photography, panoramas, or any phantasmagoric production. Seurat's work renders evident the constructed and artificial nature (on several levels) of illusion, making it part of the work itself—in a sense an anti-phantasmagoria. If there is a latent critique of Wagnerism

259. Descriptions, illustrations, and photographs of Bayreuth were widely available in France throughout the 1880s. See for the example the images of the Festspielhaus interior accompanying Adolphe Jullien, "Les Maitres Chanteurs de Nuremberg de Richard Wagner," *L'Art* 45 (1888), pp. 153–160.

260. Emile Verhaeren, "Georges Seurat," *La société nouvelle*, April 30, 1891, 429–438; reprinted in *Seurat: Correspondances, témoignages, notes inédites, critiques*, ed. Helene Seyres (Paris: Editions Acropole, 1991), 272–282. For a brief but provocative discussion of the relation between Seurat and music, see Lebensztein, *Chabut*, pp. 67–76.

261. The issue here clearly touches on the construction of a mythology of Bayreuth by converted enthusiasts. Seurat and others might well have been stunningly disappointed to see the actual stagecraft. For the early performances of the *Ring* "there had been so much talk beforehand about technological wonders that a let-down was inevitable. It was all the greater because the novel stage effects were what most often failed. The magic fire—gas jets in fact—seemed neither magic nor fire. The rainbow bridge put Hanslick in mind of a 'seven colored sausage.' The *Ring* zoo, especially the dragon, aroused embarrassment. The magic lantern slides portraying the ride of the Valkyries could be deciphered only by those close to the stage." Frederic Spotts, *Bayreuth: A History of the Wagner Festival* (New Haven: Yale University Press, 1994), p. 74.



Cartoon titled "The Modern Knights of the Grail," showing Liszt, Wagner, and von Bulow, 1882. Reprinted in Jullien, *Richard Wagner: Sa vie et ses oeuvres*, 1886.

in *Parade de cirque*, it is not that the painting is a counterimage of a popular, low-life urban street entertainment thrown up against the reverential pretensions of his Wagnerian friends. Even the most class-conscious commentators have seen little in it that is celebratory of urban street culture. Rather, *Parade de cirque* can be read as a ruthless dismantling of the Wagnerian model of spectacle, a bitter parody and unmasking of its attempt, incarnated in the central figure, to combine myth and music as social rite, and to valorize the artwork as a figuration of a unified community in the making. The trombone, in the popular press, had been singled out as a visual element of Wagnerian performance that was useful for comic caricature.²⁶² Certainly Seurat's keen visual wit would have registered the identity between the figure zero and the form of a ring. If the literal ring in Wagner's tetralogy was the vehicle of decadence and an annihilating cash nexus, the total *Ring* cycle was the last expression of a nineteenth-century fantasy of the recuperation of tragedy and myth, of the dream that culture could make whole what capitalism had broken apart. As Philippe Lacoue-Labarthe has remarked, the fantasy encompasses

262. For example, a cartoon, reproduced in Adolphe Jullien's popular monograph *Richard Wagner: Sa vie et ses oeuvres* (Paris: J. Rouam, 1886) showed two leading Wagnerians, Franz Liszt and Hans von Bulow, holding trombones while flanking their master, beneath the "grail" of a beer stein. In recent music historiography, it has been noted that "the sound of trombones in Wagner calls to mind such heroic unison tunes as the Act III Prelude in *Lobengrin* or the Ride of the Valkyries." Jonathan Burton, "Orchestration," in Barry Millington, ed., *The Wagner Compendium* (New York: Schirmer, 1992), p. 344.

the disturbing conviction “that, in an age where transcendence fails and is undone, the vocation of art can still be to recover an ancient destination and establish the type; or, if one prefers, the mythological figure, where humanity (a people, for example), could recognize itself.”²⁶³ Seurat, despite his fascination with the phenomenon of Wagner and the revalorization of theater, exposes the spuriousness and desiccation of this dream, as the banality of his “Panathenaic procession” in *La Grande Jatte* makes clear. But his resistance to Wagner’s images should not be thought of in terms of a counteradvocacy of representations of concrete social and historical reality. As Michel Foucault has insisted, writing about the late 1970s Boulez/Chareau production of the *Ring*, “The nineteenth century was full of images which were the true reason for Wagner’s great mythological reconstructions, which they changed and concealed . . . that nineteenth century world of images which Bakunin probably shared with Marx, Dickens, Jules Verne, Bocklin, the architects of bourgeois factories and villas, with the illustrators of children’s books and the agents of anti-Semitism.”²⁶⁴ Seurat’s paintings must also be seen as part of this eclectic composite imaginary of the nineteenth century.



I want to pursue these issues of the crowd, theater, and phantasmagoria along a parallel historical track. *Parade de cirque* has often been discussed in relation to another work—Seurat’s last major painting (which at his death remained unfinished), *Cirque* of 1890–1891. In certain ways *Cirque* can be read as a pendant to the earlier work—on one level, it reveals to us what is completely excluded in *Parade de cirque*. That is, it shows the interior spectacle to which people, like those observers in the earlier work, have paid admission and now sit as spectators. If *Parade de cirque* was, as I’ve tried to suggest, a disclosure of the absence at the heart of modern spectacle and perception, *Cirque* might seem to be a replenishing of the void in the earlier work, a vivid opening onto a light-filled, action-filled arena. The motionless and nocturnal world of the space-drained *Parade de cirque* apparently gives way to a concrete vision of the attractions (and the entertainment commodity) that it had evoked but withheld. The relation between the two paintings can also be articulated in terms of two fundamentally different organizations of theatrical space: the classical or Italianate “scenography” that is implicit in *Parade de cirque* (even as Seurat dismantles it), which I have shown above, and the much older historical form of the circus or arena. But in spite of these distinctions

263. Philippe Lacoue-Labarthe, *Musica Ficta: Figures of Wagner*, trans. Felicia McCarren (Stanford: Stanford University Press, 1994), p. 59.

264. Michel Foucault, “Nineteenth Century Imaginations,” *Semiotexte* 4, no. 2 (1982), pp. 182–190.

and apparent oppositions, both paintings are dissolutions of these older scenes of representation. The importance of *Cirque* has less to do with the contemporary actuality of any circus show and audience in 1890 and more to do with an investigation of the *conditions* under which a subject could be activated as an attentive perceiver.

If Verhaeren's remarks about Seurat's secondhand knowledge of Bayreuth are accurate, we see perhaps the most obvious (and literal) attempt to put them into practice here: the use of darker and wider frames to accentuate the brightness of his image.²⁶⁵ Gustave Kahn, based on conversations with the artist, says Seurat took from Wagner a conception of the frame as "an isolating agent."²⁶⁶ This particular conceptualizing of the frame is another explicit renunciation of both the classical and even early modernist status of the image—it is posed neither as a windowlike plane intersecting a cone of vision nor as a flat plane covered with colored patches. Seurat attempts, as he believed Wagner had done, to make an autonomous and luminous field of attraction, with a deliberately ambiguous spatial identity. So much of Seurat's preoccupation with color is both an obsession with light and with techniques to master it. We know well that he believed his deployment of optical mixture (that is, of separate pure colors combined on the retina) would produce luminous effects more intense than anything possible by traditional pigment mixture.²⁶⁷ In a very general sense, then, we can link this feature of Seurat's work with other optical experiences in the nineteenth century that severed the image from any continuous or intelligible relation to the position of the observing subject, such as the diorama or the stereoscope. There are many places in the late nineteenth century where an image's apparitional value is an effect of its detachment from or cancellation of a broader visual field. But clearly the content of this painting too, like that of *Parade de cirque*, seems willfully re-

265. Verhaeren also expressed his own skepticism about Seurat's use of framing to set off his work. Seurat's mistake, he writes, lies in not realizing "that in the theater the contrast is continued and extends itself to meet the eye of the spectator, while on the wall of a room or gallery, it has, so to speak, no space, the frame being narrow and bordering the picture the way a binding or hem borders a piece of drapery." Verhaeren, "Georges Seurat," reprinted in Broude, ed., *Seurat in Perspective*, p. 28.

266. Gustave Kahn, "Seurat," *L'Art moderne* 11 (April 5, 1891), pp. 107–110; reprinted in Broude, ed., *Seurat in Perspective*, p. 22. See the valuable discussion of the larger issue of the painted frame in neoimpressionist practice during the late 1880s and early 1890s, in Ward, *Pissarro, Neo-Impressionism, and the Spaces of the Avant-Garde*, pp. 118–122. Ward is one of the very few art historians to recognize the centrality of attention as a problem for Seurat and, subsequently, for others in his circle.

267. Seurat's follower Paul Signac declared that "the separation of elements and optical mixtures produces purity, that is to say, luminosity and intensity of tones," in his *D'Eugene Delacroix, au neo-impresionisme* (1899; Paris: Hermann, 1978), p. 119. See also the account in Felix Feneon, "Neo-Impressionism" (1887), in Linda Nochlin, ed., *Impressionism and Post-Impressionism, 1874–1904* (Englewood Cliffs, N.J.: Prentice-Hall, 1966), pp. 110–112.

mote from ambitions related to a Wagnerian aesthetic. I am suggesting that Seurat's interest in the "Bayreuth effect" is more usefully understood in terms of his proximity to another collective visual experience—precinematic forms of moving images, projection, and animation.

Within the dense and contentious space of cinematic prehistory, one well-known but marginalized figure is Emile Reynaud, who worked continuously from the mid-1870s to the mid-1890s on various devices for the simulation of movement.²⁶⁸ In many reductive histories of cinematic technology, Reynaud is positioned as a technical contributor: he is credited with developing the use of a continuous, flexible translucent band or strip on which individual images could lie in sequence, a band that he then regularly perforated with a single hole to facilitate its controlled passage through a projection device. His deployment of celluloid was, in conventional histories, simply one of the ingredients that would coalesce into a more fully articulated cinematic apparatus by the mid-1890s. Perhaps more significantly, Reynaud's commercial "screenings," if we can use this anachronism, at the Musée Grevin in Paris beginning in 1892 are generally considered to be the first public experience of projected moving images from film (what were effectively animated cartoons). What Reynaud did *not* do up to that point was to pursue any strategies for working with *photographic* images, for almost all of his productions involved his own hand-made drawings. Thus while he grasped something essential about the mechanical arrangements necessary to animate still images, he is also seen as a figure still trapped in older artisanal modes of production, committed to what frankly were inefficient means of making his brief film strips—spending months making hundreds of drawings on the strip itself, and hand-coloring them, for a display that would last only a few minutes. During the most productive years of his career, he never showed any interest in working with images mechanically produced by a photographic camera.²⁶⁹

268. On Reynaud, see the invaluable monograph by Dominique Auzel, *Emile Reynaud et l'image s'anima* (Paris: Du May, 1992). See also *Emile Reynaud, peintre de films* (Paris: Cinematheque française, 1945; rpt. Paris: Editions Maeght, 1992); Laurent Mannoni, *Le grand art de la lumière et de l'ombre* (Paris: Nathan, 1995), pp. 339–358; Georges Sadoul, *L'histoire generale du cinema*, vol. 1 (Paris: Editions Denoel, 1948), pp. 111–128, 237–250; Leo Sauvage, *L'affaire Lumiere: Enquete sur les origines du cinema* (Paris: Lherminier, 1985), pp. 49–72; Gilles Ciment, "Dessins inanimés, avez-vous donc une âme?," *Positif* 388 (June 1993), pp. 48–49; and Vanessa Schwartz and Jean-Jacques Meusy, "Le Musée Grevin et la cinématographe: l'histoire d'une rencontre," *1895*, no. 11 (December 1991), pp. 19–48. Reynaud's idiosyncratic importance is also discussed in François Dagognet, *Philosophie de l'image* (Paris: J. Vrin, 1986), pp. 56–57.

269. See, for example, the account in Alan Williams, *Republic of Images: A History of French Filmmaking* (Cambridge: Harvard University Press, 1992), pp. 15–16, which sets up Reynaud as a provincial bricoleur: "But compared with the true camera, the spectacle at the Musée Grevin was *incompletely mechanized*. Reynaud gave performances rather than mere projections." (Emphasis in original.)

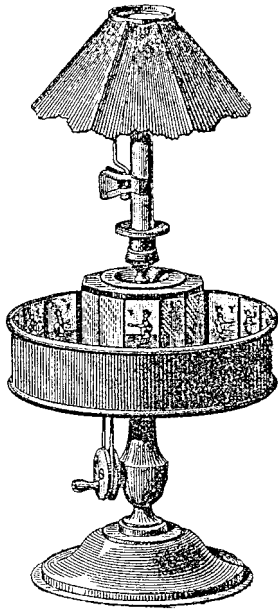

Emile Reynaud, Praxinoscope, 1876.

But this is hardly a fair or useful account of Reynaud, and it will ultimately be more interesting to consider why he seems to have willfully distanced himself from the crucial mimetic component of the cinematograph to come. To begin with, Reynaud's career has certain loose similarities to Edison's. Both were hands-on inventors who continually assessed the relationship between their own technological products and the makeup of their audience and the economic realities of the marketplace. Reynaud's output bespeaks a continuing effort to update, to modify his machines both in terms of performance and of shifting audience needs and possibilities. Even if he concretized it only in a modest way, Reynaud grasped, as did Edison, the relationship between hardware and software and only produced viewing and projection devices for which he would supply the visual "software." In this respect, even if there was an artisanal aspect to the fabrication of his film strips, he was a media entrepreneur far ahead of many of his contemporaries in his immersion in the logic of modernization (although he finally came up short in the late 1890s when his attempts to develop a marketable stereo-cinema proved unsuccessful.) From his early Praxinoscope, which sold over 100,000 models between 1876 and 1877, to the Théâtre-Optique in the 1890s, which drew over half a million spectators during the eight years of its public existence, Reynaud produced objects that can hardly be called marginal.

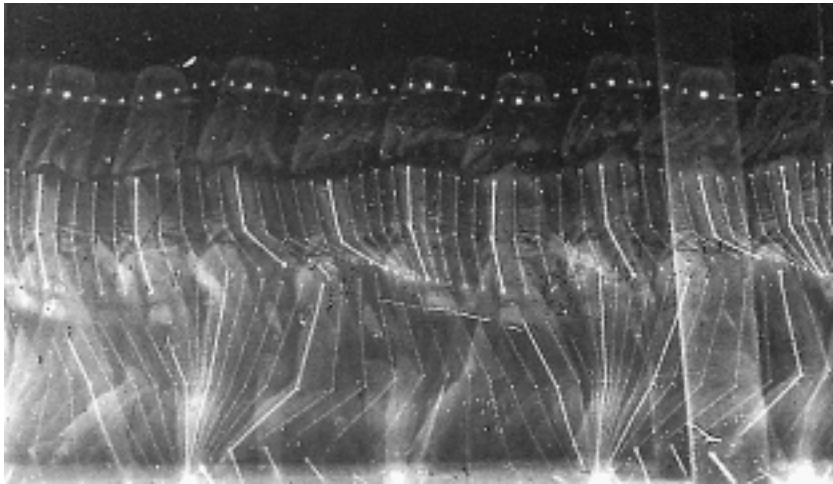

Jules-Etienne Marey, chronophotograph of man walking, late 1880s.

close enough that the individual touches of color are distinguishable and the constructed nature of the surface is evident, to a more distant point at which the surface coalesces into a shimmering image of a recognizable world. One might understandably claim that this is how we also experience older art, say a late Rembrandt or a Velazquez, but Seurat shows a self-conscious and systematic awareness of the part played by the spectator in the making of the work. It is very likely that he thought carefully about the different effects of the surface from specific distances and thus made his art for a mobile spectator who would occupy multiple viewpoints.²³ Seurat, like others around this time, was testing the limits and possibilities of an observer attentive to a heterogeneity and simultaneity of sensory data. Specifically, he examined how an irreducible plurality of luminous information could be organized and perceived coherently, but also how it could be rearranged and made exchangeable. It is in this sense that Seurat's exploration of new perceptual modalities can be compared with the physiologically based work of Etienne-Jules Marey. Marey's images, especially in the late 1880s with their overlapping transparencies, are also a repudiation of perceptual fusion, in that they constitute a visual field in which the viewer shifts back and forth between different levels of

23. David Sutter, the Swiss aesthetician whose work Seurat studied, wrote: "The distance of the spectator to the painting is an *arbitrary distance*, for it varies according to the nature of the subject one is treating." Sutter, *Nouvelle theorie simpliffee de la perspective* (Paris: Jules Tardieu, 1859), p. 24; emphasis in original.

organization—between a holistic perception of a single temporal vector and an aggregate apprehension of isolated positions.

Ernst Mach's highly provisional notion of sensation may provide a frame for understanding its ambiguous position in Seurat's work as well. Mach used the word "sensation" without attributing to it any ultimate truth value, just as he rejected the idea of the real existence of atoms. For Mach, it was most *useful* to assert that the world consisted of "colors, sounds, temperatures, pressures, spaces, times," which he preferred to call "elements." These elements "are connected with one another in manifold ways: and with them are associated moods of mind, feelings and volitions. Out of this fabric, that which is relatively more fixed and permanent stands prominently forth, engraves itself in the memory, and expresses itself in language. Relatively greater permanency is exhibited, first, by certain *complexes* of colors, sounds, pressures and so forth, connected in time and space, which therefore receive special names and are designated *bodies*. Absolutely permanent such complexes are not."²⁴ What Mach and Seurat both renounce is any attempt to give an objective picture of the world; instead they each seek provisional and practical ways of representing various complexes of elements that have no essential substance or permanence. That which appears as a distinct body or object is effectively "an economy of mental representation." Crucial for both of them is the usefulness of multiple points of view and systems of representation: for Seurat, perceptual experience is presented simultaneously in terms of a schematic realism, a decomposition of the properties of luminous phenomena, and an analysis of the chromatic sensibility of the human retina. None of these levels has any priority. Mach too made it clear that he neither rejected nor affirmed naive realism; rather it was a view of the world that was useful in many situations, though he felt it rarely advanced scientific understanding. Ian Hacking proposes the early 1890s as the time when Western science accepts the notion "that there might be several ways to represent the same facts." He cites the 1894 book by physicist Heinrich Hertz, *Principles of Mechanics*, as emblematic of this turning point: in it Hertz outlines "three images of mechanics, three different ways to represent the then extant knowledge of the motion of bodies."²⁵ For both Mach and Hertz, physics

24. Ernst Mach, *Contributions to the Analysis of the Sensations* (1885), trans. C. M. Williams (La Salle, Ill.: Open Court, 1890), p. 2. Translation modified.

25. Ian Hacking, *Representing and Intervening: Introductory Topics in the Philosophy of Natural Science* (Cambridge: Cambridge University Press, 1983), p. 143. Hacking associates this shift in scientific practice with postimpressionism, which also proposed "new systems of representation" in the 1880s. Henri Poincaré discussed the ephemeral nature of scientific theories and, citing Hertz, insisted that "it may be shown that we can explain everything in an unlimited number of ways." Poincaré, *Science and Hypothesis* (1902), trans. J. Larmor (New York: Dover, 1952), p. 168.

was fundamentally a question of *perception*. But unlike Hertz, Mach ultimately believed (as did Nietzsche, Bergson, Richard Avenarius, Hans Vaihinger, and others) that scientific rationality had to be in the service of life. The value of any scientific account was the extent to which it satisfied human biological needs, the extent to which it was life-enhancing.

The question of whether a representation of the world could in some way be life-enhancing traversed both aesthetic and philosophical thought at this time. Seurat is particularly relevant in terms of his investigation of how visual stimuli could produce various physical and psychological states, including happiness and tranquillity. He clearly explored many theoretical explanations, some long established, of how emotional response could be controlled, but most significant was his interest in relatively contemporary ideas that involved the concepts of “dynamogeny” and “inhibition.”²⁶ We will never know with any certainty or specificity how Seurat engaged these concepts, nor will anything be learned by studying Seurat’s paintings as if they were attempted “applications” of a theory to an artistic practice, even though it is clear that he became interested in these ideas while planning *Parade de cirque*.²⁷ If indeed this body of knowledge was effectively adjacent to Seurat’s practice (and there is very little reason to suspect it was not), it is important to understand the nature of the powerful institutional discourses in which they were formed and operated and how they are linked with the conflicting ambitions of *Parade de cirque*.

Seurat’s practice intersects with a model of the human subject that became increasingly dominant in a number of fields during this period, and had wider cultural effects as well. The notion of “dynamogeny” comes out of some of the most significant experimental physiological work of the nineteenth century, in

26. It has long been known that Seurat was familiar with the work of D. P. G. Humbert de Superville, who had attempted a theory explaining the expressive values of both color and line in his *Essai sur les signes inconditionnels dans l'art* (1827). Humbert’s work was summarized in Charles Blanc, *Grammaire des arts du dessin: architecture, sculpture, peinture* (1867; Paris: H. Laurens, 1880). Of course what separated these earlier accounts from dynamogenic/inhibitory explanations of such effects is that they were not linked to a comprehensive accumulation of knowledge about the body, brain, and nervous system.

27. Robert Herbert has shown that by 1887 Seurat was familiar with Charles Henry’s exposition of these ideas, in his “‘Parade de cirque’ de Seurat et l’esthétique scientifique de Charles Henry,” *Revue de l’art* 50 (1980), pp. 9–22. Herbert has more recently amended some of his conclusions in this article but nonetheless reaffirms that, before beginning *Parade de cirque*, Seurat had assimilated from contemporary physiology the notion “that all emotional responses, including unconscious ones, can be traced to the activity of nerves and muscles that reflect the relative ease or discomfort induced by the stimulus.” See his “Appendix L: Charles Henry,” in Herbert, *Georges Seurat, 1859–1891*, pp. 391–393. There, Herbert also cautions against attempting to find specific formal correlations between Seurat’s work and Henry’s system of movements and directions.

particular work from the 1850s and 1860s, which constructed models of the reflex functioning of the human nervous system and investigated the nature of human response to external stimulation. For a long time it was wrongly assumed by many art historians that these concepts were the invention of Seurat's friend, the librarian and quasi-scientist Charles Henry, but in fact they were part of a large and collective body of psychological and neurological concepts that by the end of the 1880s had become widely familiar and influential.²⁸ Such research was assembling a detailed reconfiguration of a human subject, which would be central to a vast range of modernizing projects in the West well into the twentieth century, and more specifically a new inventory of the capacities and functions of an attentive observer.

The chief figure involved in the early diffusion (and most likely coinage) of the term "dynamogeny" was the French-American physiologist Charles-Edouard Brown-Sequard (1817–1894).²⁹ Much of his research studied the connection between sensation and reflex movements, and he classified various normal and pathological functions of the nervous system in terms of this relation. Like others before him, he noted effects of "inhibition": that certain kinds of irritation or stimulation (whether from sound, light, electricity, or touch) of one nerve center could dampen or diminish action at another distant center, producing a kind of anesthesia. His work was to be an important part of Théodule Ribot's claim that attention was dependent on the body's capacity for the inhibition of certain motor centers.³⁰ In the late 1870s Brown-Sequard concentrated on the opposite properties by which stimulation produced a heightening or augmentation of function, usually

28. One of the first texts to establish some of the sources for Henry's formulations was Jose Arguelles, *Charles Henry and the Formation of a Psycho-physical Aesthetic* (Chicago: University of Chicago Press, 1972). More recently, Michael Zimmermann has produced an extended survey of the intellectual and cultural context of Seurat's work, including accounts of the relevant theories of Brown-Sequard, Fere, Henry, and many others, in his massive *Seurat and the Art Theory of His Time* (Antwerp: Fonds Mercator, 1991). See the valuable chapter on "Physiological Aesthetics" in Martha Ward, *Pissarro, Neo-Impressionism, and the Spaces of the Avant-Garde* (Chicago: University of Chicago Press, 1994), pp. 124–146.

29. His ideas were initially articulated in Charles-Edouard Brown-Sequard, *Physiology and Pathology of the Central Nervous System* (Philadelphia: Lippincott, 1858). For a statement of his neurological model in its mature form, see Charles-Edouard Brown-Sequard, *Recherches experimentales et cliniques sur l'inhibition et la dynamogenie* (Paris: Masson, 1882). See the memorial article on Brown-Sequard in the journal that he founded with Charcot in 1867 and of which he was the sole editor from 1889 until his death, E. Gley, "C.-E. Brown-Sequard," *Archives de physiologie normale et pathologique*, 5th ser., 6 (1894), pp. 759–770. See also J. M. D. Olmsted, *Charles-Edouard Brown-Sequard* (Baltimore: Johns Hopkins University Press, 1945), esp. pp. 159–167. Brown-Sequard's historical significance in nineteenth-century psychophysiology is discussed in Roger Smith, *Inhibition: History and Meaning in the Sciences of Mind and Brain* (Berkeley: University of California Press, 1992), pp. 130–133.

30. Théodule Ribot, *The Psychology of Attention* (1889; Chicago: Open Court, 1896), pp. 40–41.

accompanied by vasocongestion, in some other part of the nervous system, which he called “dynamogenesis.”³¹ By 1885, his model of the human organism had certain thermodynamic features: “I hardly need to say that in both cases [dynamogeny and inhibition] it is a question of a transformation or displacement of forces, since these cannot be destroyed or created.”³² Thus it was part of a larger and pervasive *economic* conception of organic function, also one of the conditions of possibility for later dynamic psychological and neurological theories. Although the word *dynamogeny* had a relatively brief currency of perhaps twenty-five years, it effectively was deployed in the 1880s and early 1890s to mean the same thing as the term “excitation.” Thus the eventual obsolescence of the term (or its origin in the particularities of Brown-Sequard’s understanding of the nervous system) should not obscure the cultural significance of the concepts it ponderously though evocatively designated. *Inhibition*, however, clearly has had a different and far more durable destiny as a signifier. In the work of Hughlings Jackson and others, inhibition was privileged outside of any duality as an integrative force that prevented the dissolution of higher, organized mental functions by “inhibiting” lower and instinctual processes.

In the 1880s and well into the 1890s, other researchers continued to use these terms to describe related phenomena. Rather than discuss Charles Henry’s appropriation and use of these ideas, I will briefly mention a more widely read figure whose work was equally accessible to Seurat.³³ Charles Fere, who had been

31. It has been noted that dynamogeny, as a stimulation of functioning, is related to the concept of “facilitation” as it developed in the 1895 “Project” of Freud and in the work of his former teacher Sigmund Exner. Jean Laplanche and J. B. Pontalis define this term: “Excitation, in passing from one neurone to another, runs into a certain resistance; where its passage results in a permanent reduction in this resistance, there is said to be facilitation; excitation will opt for a facilitated pathway in preference to one where no facilitation has occurred.” Laplanche and Pontalis, *The Language of Psychoanalysis*, trans. Donald Nicholson-Smith (New York: Norton, 1973), p. 157.

32. Charles-Edouard Brown-Sequard, “Dynamogenie,” in *Dictionnaire encyclopédique des sciences médicales*, 1st ser., vol. 30 (Paris: Asselin, 1885), pp. 756–760. For an exposition of these ideas in a popular science magazine, see L. Menard, “L’inhibition,” *Le Cosmos: Revue des Sciences* 71 (June 4, 1887), pp. 255–256. Brown-Sequard’s position in the development of nineteenth-century dynamic psychologies is outlined in Henri F. Ellenberger, *The Discovery of the Unconscious: The History and Evolution of Dynamic Psychiatry* (New York: Harper, 1970), pp. 289–290.

33. Charles Henry, during the same years as Fere, assimilated these ideas, and his work has been discussed at length in many art historical studies of Seurat. Drawing on earlier nineteenth-century studies on art, Henry attempted to account for the physiological effect of colors, movements, rhythms, and directions. He insisted that “every stimulus is dynamogenic or inhibitory,” to a lesser or greater degree. See, for example, his “Le contraste, le rythme, la mesure,” *Revue philosophique* 28 (1889), p. 364. He formulated a complex, often incoherent system, using his proprietary “aesthetic protractor,” in which movements are dynamogenic or inhibitory according to whether they are continuous or discontinuous, or whether they go from left to right or right to left, and upward or downward. See Arguelles’s tendentious yet sometimes useful *Charles Henry and the Formation of a Psycho-physical Aesthetic*. I strongly

personal assistant to and then a colleague of Charcot, conducted experiments on human subjects in which he measured physiological response to various forms of stimulation and attempted to quantify the relative strength or weakness of dynamogenic or inhibitory effects. He and others at the clinics of the Salpêtrière and Bicêtre used a device called a dynamometer which measured the pressure exerted by the hand grip of a test subject as that subject was exposed to (and specifically asked to be attentive to) various kinds of stimuli. It yielded a graphic indication (called a *dynamographe*) of the rise and fall of that muscular pressure in relation to the external variables.³⁴ Of the many kinds of demonstrations cited by Fere, the most relevant here are his optical experiments, in particular those involving color. In describing the physiological effects of luminous impressions, Fere showed that orange and red produced heightened physical response in both “normal” and “hysterical” subjects.³⁵ Blue and violet produced a diminution in measurable physical response, i.e., an inhibitory effect. Perhaps the most significant part of Fere’s research was the conclusion that attention itself could have dynamogenic characteristics: that is, the heightened state of alertness, effort, or tension created condi-

disagree with Arguelles’s picture of Henry as the prophetic voice of a “scientific-mystical aesthetic” of the future. Like many commentators, he ignores Henry’s less lofty interest in the application of psychological and physiological knowledge to forms of social control and the rationalization of labor, and he barely mentions his sad end in the 1920s as he tinkered with the invention of proto-Reichian “bio-resonators.” To fully understand Henry’s dilettantish career, one probably ought to look less at parallels with Pythagoras and Leonardo and more at those with Flaubert’s Bouvard and Pecuchet, that is, to the social identity of Henry as a bourgeois librarian and autodidact at the Sorbonne and to related nineteenth-century fantasies of a universality of knowledge in all its newly reified and consumable forms, about which Flaubert has said the last word. One can also position Henry in relation to Philip Nord’s observation that Third Republic print culture “nursed pedagogical ambitions of a scientific, encyclopedic cast” based on a utopian “imagining of a universal order in which human beings might live in harmony with nature and themselves.” Nord, *The Republican Moment: Struggles for Democracy in Nineteenth-Century France* (Cambridge: Harvard University Press, 1995), p. 191.

34. The origins of the dynamometer go back into the eighteenth century according to Anson Rabinbach, who details the history of various devices used for quantifying the force of human effort, in his *The Human Motor: Energy, Fatigue, and the Origins of Modernity* (New York: Basic Books, 1990), p. 30. Fere’s devices and graphical method were probably derived from the work of E. J. Marey. See the related discussion in Marta Braun, *Picturing Time: The Work of Etienne-Jules Marey* (Chicago: University of Chicago Press, 1992), pp. 321–323. For an account of Fere’s experimental practices at the Salpêtrière in the 1880s, see Dianne F. Sadoff, *Sciences of the Flesh: Representing Body and Subject in Psychoanalysis* (Stanford: Stanford University Press, 1998), pp. 91–100.

35. Henri Bergson dubiously acknowledged the significance of Fere’s work, indicating how it was bound to an impoverished notion of sensation: “Doubtless, a closer examination of what takes place in the whole of the organism when we hear such and such a note or perceive such and such a color has more than one surprise in store for us. Has not Charles Fere shown that every sensation is accompanied by an increase in muscular force which can be measured by the dynamometer?” For Bergson, such demonstrations are ultimately irrelevant since they fail to understand the essential indivisibility and interpenetration of the psychic states related to such sensations. Bergson, *Time and Free Will* (1888), trans. F. L. Pogson (New York: Harper, 1960), p. 41.

tions within the nervous system for heightened reactions to sound and color in particular.

Several points should be emphasized. One is that the model of the attentive subject here is emphatically a nonoptical one. That is, the subject here is not one who primarily sees but rather one who is susceptible to what Fere called “psychomotor induction.”³⁶ In the words of his teacher Charcot, it was a question of “the dynamogenic influence of the visual on the motor center.”³⁷ Color, as certain wavelengths of luminous energy, has effects not on an autonomous optical sensibility of the spectator but on the body as a complex nervous and motor organism. Fere goes so far as to make this extraordinary formulation: “When rays of red light strike our eyes, *our entire body sees red*, as dynamometric reactions prove.”³⁸ The repudiation of a classical optical model in this remarkable sentence is a concise summation of one of the most powerful ways in which vision was reformed in the nineteenth century. Following the graphical method of E. J. Marey’s physiological studies, Fere’s dynamographs are evidence of how what were once figured as visual representations are now the abstract and quantified reactions of the body as a composite set of physical systems.³⁹ Far from discovering any “natural” functions, Fere’s work is part of a larger *instrumental* relocation of vision from a disembodied and punctual system of images to an interplay of forces and motor reactions in which representations play an irrelevant role. The truth of seeing is shifted to a completely nonoptical terrain. The retina is now compounded with a neuromotor system that is triggered externally. Sensation and movement become a single *event*. It is no longer a question of a single discrete sense but of the senses producing exchangeable effects and responses, and of different sensory stimuli being “translated” into the same movements or tensions.

Dynamogeny comes out of knowledge in which the meanings of “sensation” have shifted almost unrecognizably from those of the beginning of the nineteenth

36. Charles Fere, *Sensation et mouvement* (1887; Paris: F. Alcan, 1900), p. 87. Fere’s work is inseparable from a larger project of social “prophylaxie,” and from a Spencerian linking of national prosperity with the scientific amelioration of collective emotional hygiene. See, especially, his *La pathologie des émotions* (Paris: Felix Alcan, 1892), pp. 553–572.

37. J.-M. Charcot, *Clinical Lectures on Diseases of the Nervous System*, ed. Ruth Harris (London: Tavistock, 1991), p. 310.

38. Fere, *Sensation et mouvement*, p. 152; emphasis added.

39. On Marey’s rejection of sensation and direct observation as tools of scientific investigation, see François Dagognet, *Etienne-Jules Marey: A Passion for the Trace*, trans. Robert Galeta (New York: Zone Books, 1992), pp. 15–63. For a historical overview of various modern attempts to “transcribe” bodily movement, from the 1880s to the 1920s, see Pacal Rousseau, “Figures de déplacement: L’écriture du corps en mouvement,” *Exposé 2* (1995), pp. 86–97.

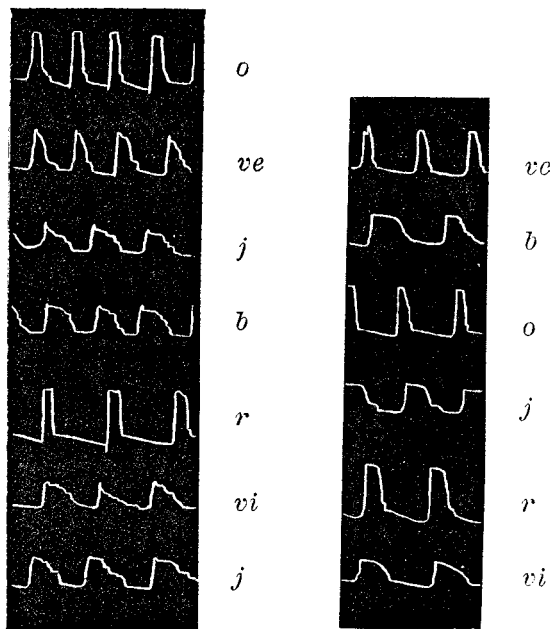

FIG. 19 et 20. — Contractions sous l'influence du rouge *r*, de l'orangé *o*, du jaune *j*, du vert *ve*, du bleu *b*, du violet *vi*. (Les tracés se lisent de droite à gauche.)

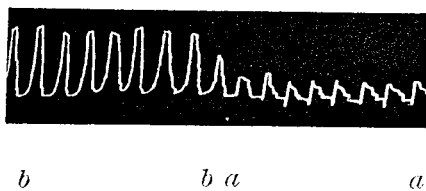

FIG. 18. — *aa*, contractions normales; *bb*, contractions sous l'influence des rayons rouges. (Le tracé se lit de droite à gauche.)

Graphical representations of dynamogenic response to color, from Charles Fere, Sensation et mouvement, 1887.

century and earlier. Sensation has ceased to designate an element of psychical processes through which a mental or visual representation of the world will be assembled.⁴⁰ Rather, it is part of a sequence of events in which the end point is not an inner state, such as knowledge or cognition or perception: instead, sensation is that which culminates in movement, regardless of whether that movement is voluntary or automatic, inner or outer. Beginning in the 1850s, there was a widespread conceptualization (by both scientists and philosophers) of a fundamental relation between sensation and motor behavior.⁴¹ Some of the rationalizing ambitions in Seurat's work are both directly and indirectly informed by these new functional models, which propose that sensory stimuli will produce a *motor* expression in a perceiver. Most importantly it is a question of human response based on the *bypassing* of conscious thought altogether, undermining the long-established image of Seurat's art as intellectual constructions directed to the rational mind of an observer. Whatever may have been its other ambitions, Seurat's method (as it

40. Martin Kemp makes a related distinction in the conclusion to his *The Science of Art: Optical Themes in Western Art from Brunelleschi to Seurat* (New Haven: Yale University Press, 1990), p. 319. He sees the overlapping concerns of Charles Henry and Seurat as marking a shift from visual analysis and the recreation of nature to a preoccupation with "the responses of the senses and the mind which comprised a new kind of psychological reality. This new thrust leads us away from the tradition of optical observation."

41. One can look back to the work of William B. Carpenter, who, by the early 1850s, had coined the term "ideo-motor action" to describe muscular movements that were induced automatically by certain ideas, occurring outside of any volitional control, in his *Principles of Mental Physiology* (1874), 7th ed. (London: Kegan Paul, 1896), p. 279. Ideo-motor actions were "the direct manifestations of Ideational states excited to a certain measure of intensity, or in physiological language, reflex actions of the Cerebrum." See the summary and critical revision of Carpenter's work in Thomas Laycock, "Reflex, Automatic and Unconscious Cerebration: A History and a Criticism," *Journal of Mental Science* 21, no. 96 (January 1876), pp. 477–498. Gustav Fechner's work also had enormous impact in terms of later dynamic or energetic models of the nervous system: "No stimulus functions passively. Some stimuli, such as light and sound, can be conceptualized directly as motions, and even if this does not hold for others, such as the stimuli of weight, smell and taste, we may nevertheless assume that these stimuli evoke or change sensations only by causing or changing some kind of activity within our body." Fechner, *Elements of Psychophysics* (1860), trans. Helmut Adler (New York: Holt, Rinehart, 1966), p. 19. The work of Ivan Sechenov, who worked briefly under Helmholtz in 1858, is also pivotal for its account of "reflexes which begin with sensory stimulation, continue in the shape of a definite psychical act and end in muscular movement"; and for Sechenov, an *involuntary* visual attention was one of the most basic of these acts. See his *Reflexes of the Brain* (1863), trans. S. Belsky (Cambridge: MIT Press, 1965), p. 43. Sechenov insists that visual attention does not depend on will: "Consequently, the primary act of vision even in the adult is involuntary. . . . The structure of the optical membrane, certain parts of which perceive light better than the other parts, is responsible for another involuntary act, the psychical aspect of which, in its highest degree, is described as 'attention in the sphere of visual sensations.' It is expressed by the clarity of perception of the image on which the attention is focussed (at which the person is looking, or to which his optical axes are directed), as well as by the decline in sensibility to the surrounding objects sometimes resulting in their complete disappearance from the field of vision." (Ibid., p. 48.) On the historical background of Sechenov's work, see M. Peter Amacher, "Thomas Laycock, I. M. Sechenov and the Reflex Arc Concept," *Bulletin of the History of Medicine* 38 (1964), pp. 168–183.

attempted, whether successfully or not, to induce different emotional and physical responses) involved *the aim* of engaging much more than the exclusively optical consciousness of the individual human subject and of producing effects involuntarily or even automatically. Regardless of whether this subject is finally “active” or “reactive,” Seurat’s project nonetheless challenged the privileged status of a *conscious* observer.

By the mid-1870s, well before Henry’s formulations, such ideas had become central elements of even mainstream aesthetic thinking. For example, the widely read *Esthétique* of Eugène Veron described aesthetic response in terms of reflex action, excitation, and contraction of muscles, and of particular lines and colors producing predictable physiological responses. An editor of the conservative periodical *L’Art*, Veron described “the transmission of excitation from one part of the nervous system to another” and stated that such effects occurred “absolutely independent of our will.”⁴² What is important here are its consequences for the status of perception: it is a model in which what previously had been exclusively in the domain of the optical (whether conceived as light rays, light waves, or luminous energy) is now part of a different system of effects and relations.⁴³ In a sense it is a new metaphoric understanding, “a complete overleaping of one sphere, right into the middle of a new and entirely different one.”⁴⁴ Light no longer leads primarily to the formation of images but to changes in the body, to redistributions of energy within an active, mobile subject.

William James discussed dynamogeny in his *Principles of Psychology*, a text that helped diffuse the term to both specialist and general audiences in Europe

42. Eugène Veron, *L’esthétique* (Paris: C. Reinwald, 1878), pp. 371–372. A related group of ideas, linking aesthetic pleasure to the automatic functioning of the nervous system, had been developed the year before in Grant Allen, *Physiological Aesthetics* (London: H. S. King, 1877).

43. John Dewey was to outline one of the most influential anti-optical aesthetic positions in his *Art as Experience* (1932; New York: Perigee, 1980), and Seurat’s neoimpressionism provided him with a crucial model (p. 122): “When some painters introduced the ‘pointillist’ technique, relying upon the capacity of the visual apparatus to fuse dots of color physically separate on the canvas, they exemplified but they did not originate an organic activity that transforms physical existence into a perceived object. But this sort of modification is elementary. It is not just the visual apparatus but the whole organism that interacts with the environment in all but routine action. The eye, ear, or whatever, is only the channel *through* which the total response takes place. A color as seen is always qualified by implicit reactions of many organs, those of the sympathetic system as well as of touch. It is a funnel for the total energy put forth, not its well-spring. Colors are sumptuous and rich just because a total organic resonance is deeply implicated in them.”

44. See the extraordinary discussion of metaphor formation and perception in Nietzsche, “On Truth and Lies in a Nonmoral Sense,” in *Philosophy and Truth*, trans. Daniel Breazeale (Atlantic Highlands, N.J.: Humanities Press, 1979), pp. 79–100.

and North America. James affirmed the same holistic account of the nervous system that had been an important part of the work of Brown-Sequard, whose lectures James had attended at Harvard in the late 1860s.⁴⁵ Both were parties of the camp which stressed that the nervous system is not simply an accumulation of local reflexes and circuits, and that because of the immense number of interconnections, reciprocal influences or reverberations of one part on another will always be a factor. Thus for James, dynamogeny was one example of how kinesthetic sensation affected the total creative behavior and emotional state of the individual, rather than being simply a localized physical event. Influential in terms of sheer readership was the two-volume *Handbook of Psychology* by the American James Mark Baldwin. This widely used textbook outlined a “Law of Mental Dynamogenesis” which proposed that “every state of consciousness tends to realize itself in an appropriate muscular movement.”⁴⁶ Also, the widely read pseudo-psychology of Herbert Spencer contained a general “aestho-physiology” that explained emotions and conscious states in terms of “simulations and discharges of nerve-force reverberating throughout the nervous system,” which was thoroughly compatible with the idea of dynamogeny.⁴⁷ By the late 1880s it had already acquired a wider cultural set of meanings associating it with any stimulus or event that produced a generalized surge of life-enhancing feelings. Max Nordau, writing about modern warfare, describes (well before Marinetti and Ernst Junger) the result of victory in battle: “The feeling of triumph is one of the most pleasurable the human brain can experience and the force-producing, ‘dynamogenous,’ effect of this pleasurable feeling is well qualified to counteract the destructive influences of

45. See William James, *The Principles of Psychology* (1890; New York: Dover, 1950), vol. 2, pp. 379–381. James indicated various ways in which a system-wide muscular contraction was either weakened or increased by various sensations, noting, for example, that when musical notes “are compounded into sad strains, the muscular strength diminishes. If the strains are gay, it is increased,” and he remarked on the powerful “dynamogenic value” of the color red. On the importance of Brown-Sequard to the formation of James’s thought, see Eugene Taylor, “New Light on the Origin of William James’s Experimental Psychology,” in Michael G. Johnson and Tracy B. Henley, eds., *Reflections on “The Principles of Psychology”* (Hillsdale, N.J.: Erlbaum, 1990), pp. 33–62.

46. James Mark Baldwin, *Handbook of Psychology: Feeling and Will* (New York: Henry Holt, 1891), pp. 280–282. The English psychologist and editor of *Mind*, George Frederick Stout, discusses how “dynamogenic” effects increase the vigor of the nervous system in his influential *Analytic Psychology*, vol. 2 (London: Sonnenschein, 1896), p. 302. As late as 1911, a standard American textbook discussed reflex theory with reference to dynamogeny and the work of Fere, in George T. Ladd and Robert S. Woodworth, *Elements of Physiological Psychology*, new ed. (New York: Scribner’s, 1911), pp. 532–535.

47. See Herbert Spencer, *The Principles of Psychology*, 3d ed., vol. 1 (New York: D. Appleton, 1871), pp. 97–128.

the impressions produced by war."⁴⁸ It suggests the possibility of managing behavior by producing effects of "enhancement" to counteract the opposing effects of certain stimuli in order to insure specific performance parameters. At the same time, the details of certain accounts of dynamogeny suggested that a model of sexual response, applied to the entire organism, was being used to describe nervous activity of many kinds: a sudden heightening of sensation or tension, accompanied by vasocongestion in localized areas of the body.⁴⁹ But it was also an instrumental and reductive way to conceptualize and control the potential disorder of a body, whose different regions were traversed by varying intensities of energy. As I will explore later in this chapter, Seurat's work is a model of response that held at least the promise or dream of a fully unalienated, instinctual aesthetic gratification, yet could only be imagined through the impoverished systematizing of drive or of affect into a quantifiable and manageable economy of excitation, within an "organized" and controllable body.

This dimension of Seurat's work has long been associated with various late-nineteenth century manifestations of "biological romanticism" and vitalism, including art nouveau and empathy theory.⁵⁰ But in addition to Seurat's, one of the most notable (and ambivalent) responses to the same body of ideas is in the late work of Nietzsche. In spite of his suspicion of experimentalist, evolutionist, or other "reductionist" forms of knowledge, Nietzsche read fairly widely in contemporary scientific literature.⁵¹ One book he encountered, probably in late 1887 soon after its publication, was Charles Fere's *Sensation et mouvement*. He no doubt read it within the frame of his meditations on the fate of European culture, through his

48. Max Nordau, *Degeneration* (1892; New York: Appleton, 1895), pp. 207–208. Ironically, it was through Nordau's book that filmmaker Sergei Eisenstein later drew on Fere's ideas, to affirm the "dynamogenous" effects of various sense impressions, in *The Film Sense*, trans. Jay Leyda (New York: Harcourt, Brace and World, 1947), pp. 145–146. Eisenstein and Seurat can be associated as artists who struggled to reconcile rational formal clarity with techniques for stimulating emotional response. See the characterization of Eisenstein's work in Peter Wollen, *Signs and Meaning in the Cinema* (Bloomington: Indiana University Press, 1969), pp. 19–73.

49. The concrete application of a sexualized model of dynamogeny is evident in Brown-Séquard's unusual attempts to induce dynamogenic effects in human subjects by injecting "testicular fluids" under the skin. This experiment is reported in Charles Fere, "L'énergie et la vitesse des mouvements volontaires," *Revue philosophique* 28 (July–December 1889), p. 68. See also the account of such experiments, including Brown-Séquard's own self-injections, in Ellenberger, *The Discovery of the Unconscious*, p. 295.

50. The notion of *Einfühlung* in the work of Lipps and others poses a related, though certainly less materialist, model of attention. In empathy theory, *Einfühlung* described a mode of intense perceptual absorption in which lines and forms were experienced by the subject as specific motor sensations, and were the catalyst for a vitalization of the imagination.

51. For an inventory of books on science and physiology in Nietzsche's library see "Friedrich Nietzsches Bibliothek," in *Bücher und Wege zu Büchern* (Berlin: W. Spemann, 1900), pp. 437–438.

own uncertainty about whether the “manifoldness and unrest” of the late nineteenth century were conditions for a new ascent of culture or were more powerfully linked to pathological exhaustion (and also through his personal anxiety about “overstimulation” and its effects on his own fragile health). Paradoxically, Nietzsche deplored the automaton-like or reflex character of contemporary existence (life as adaptation, decadence as a physiological condition), even as he identified the primal “reality of our drives” and valued action or states that eluded a rational ego and had a powerful automatic character.⁵² Nietzsche could distinguish without hesitation between those forms of *thought* which he called reactive and active; but it was more difficult for him to make decisive evaluations within the concrete forms of material life and culture reshaping the face of Europe (for example, his uncertainty about which contemporary forms of illusion were life-affirming and which were base and trivial). So what is his response to Fere’s account of “psycho-motor induction”? Of course for Nietzsche it is a crude formulation, but also perhaps redolent enough of his own postulation of an art not confined to representation but that would “exercise the power of suggestion over the muscles and the senses,” that would communicate movements rather than thoughts.⁵³

In these late notes, Nietzsche provides piercing glimpses of an aesthetic treatise never to be completed, although there is little doubt about the persistence with which he insisted on aesthetic experience that was a feeling of increased energy and plenitude.⁵⁴ He builds on an image already articulated a few years earlier: “A living thing seeks above all to *discharge* its strength.”⁵⁵ In the *Will to Power* he lists the physiological states native to the artist: “One must first think of this condition as a compulsion and urge to get rid of the exuberance of inner tension through muscular activity and movements of all kinds; then as an involuntary coordination between this movement and the processes within (images, thoughts, desires)—as a kind of automatism of the whole muscular system impelled by strong stimuli from within—; inability to prevent reaction; the system of

52. Friedrich Nietzsche, *Beyond Good and Evil* (1886), trans. Walter Kaufmann (New York: Random House, 1966), p. 47.

53. Friedrich Nietzsche, *The Will to Power* (1888), trans. Walter Kaufmann (New York: Random House, 1967), p. 427 (sec. 809).

54. Nietzsche had tentatively sketched out a section in the fragments of *The Will to Power* titled “Toward a Physiology of Art.” He briefly describes some of its aims in *The Case of Wagner* (1888), trans. Walter Kaufmann (New York: Random House, 1967), p. 169. See the related discussion in Martin Heidegger, *Nietzsche*, vol. 1: *The Will to Power as Art*, trans. David Farrell Krell (New York: Harper and Row, 1979), pp. 92–106.

55. Nietzsche, *Beyond Good and Evil*, p. 21; emphasis in original.

inhibitions suspended as it were. Every inner movement (feeling, thought, affect) is accompanied by vascular changes and consequently by changes in color, temperature and secretion.”⁵⁶ When he refers to “inner movement” and “processes within,” he is attempting to express the idea of a force that cannot be understood mechanistically, of a force that initiates and imposes itself through its own inner dynamism. Nietzsche’s “physiology” here has little in common with the tedious biometric imperatives of Fere’s work; yet the binary system of dynamogeny and inhibition was clearly a figuration of the richer (and immeasurable) energies that Nietzsche intuited at work within the subject.⁵⁷ It is merely another image of *two types of force* that Nietzsche endlessly recast into active and reactive, strong and weak, ascending life and decadence, forgetfulness and memory. But central to his late thought was the distinction between contemporary *mechanistic* conceptions of force and his own dynamic model of a “will to power,” in which the play of forces constituted an inner dynamic capable of creating, of initiating something new. When Fere declares that dynamogenic sensations of pleasure are inseparable from a sensation of power, it is for Nietzsche merely a confirmation from another (lower) vantage point that “the condition of pleasure called rapture is precisely an exalted feeling of power . . . ‘intelligent’ sensuality—; strength as a feeling of dominion in the muscles, as suppleness and pleasure in movement.”⁵⁸ At the same time Nietzsche is contemptuously dismissing reductive Darwinian postulations that instinctual behavior must be understood in terms of mere preservation or survival of the organism.

And if we can draw a diagonal from Seurat (through Féré) to Nietzsche, it is finally because for both of them the question of meaning in art was not about representation but a relation of forces, and that art is not a semiology but a physics. Color for Seurat was not something accessible as a sign to a sovereign gaze but

56. Nietzsche, *The Will to Power*, pp. 428–429 (sec. 811).

57. Attention, of course, is inseparable from what Nietzsche called “the reality of our drives,” inseparable from the libidinal body of Freud’s work. John Rajchman has cogently reminded us that the “libidinal body is not the same thing as the anatomical or physiological body, and has another sort of relation to our living. Nor is the libidinal body the instinctual body. For ‘drives,’ unlike instincts are not tied to specific conditions of satisfaction, but are submitted to an open-ended ‘plasticity,’ ever susceptible to ‘substitutions’ in their objects and aims. Our drives are constantly missing their aims and deviating from their objects, and that is why our ‘desire’ is not a ‘need’ identifiable by what satisfies it.” Rajchman, *Truth and Eros* (New York: Routledge, 1991), p. 33.

58. Fere, *Sensation et mouvement*, pp. 66–68; Nietzsche, *The Will to Power*, pp. 420–421 (sec. 800). Following more recent translators, I have modified Kaufmann’s rendering of Nietzsche’s “Rausch” from “intoxication” to “rapture.”

was an interpretation made by the body, an instance of what Nietzsche described as our drives interpreting the world.⁵⁹ Experience for both Seurat and Nietzsche is never unified but always a multiplicity of conflicting impulses, and the quality of this experience is only a differential of the quantity of two forces. Seurat's elusive goal of Harmony was, in the late 1880s, a question of a relative equilibrium of forces, never a fixed set of formal or binary relations as is so often claimed. Of course the whole rhetorical terrain of stimulation, of dynamism, of Henry's and Fere's sensations of power and strength, seems alien and remote from the apparent serenity and "classicism" of so many of the paintings in question, whether *Parade de cirque* or the late seascapes from Gravelines.⁶⁰ But Seurat may well have sensed, as had Nietzsche, that there was an "extreme calm in certain sensations of rapture (more strictly the extreme retardation of the feelings of time and space). . . . The classical style is essentially a representation of this calm, simplification, abbreviation, concentration—the *highest feeling of power* is concentrated in the classical type. To react slowly; a great consciousness, no feeling of struggle. . . . Logical and geometrical simplification is a consequence of enhancement of strength."⁶¹

The question about the nature of the human subject presupposed by Seurat's practice remains unanswerable in any definitive form. To what extent can we characterize this subject, in Nietzschean terms, as merely *reactive*? On one hand Seurat is clearly comfortable working within a discourse derived from empirical research on what are essentially stimulus-response mechanisms, a set of related techniques for the external management of aesthetic response, that are ultimately a kind of quantifiable emotional engineering. Is Seurat's spectator a being that is acted upon, that in a sense "obeys" a predetermined program of effects? Or is this physiological subject a body that creates, invents, and affirms? But these questions presuppose a subject that is a unity, with a conscious will to be overcome. Is a work like *Parade de cirque* merely an activation of forces whose effects depend on the

59. Nietzsche, *The Will to Power*, sec. 481.

60. At the same time it is hardly a question of a literal setting in motion of the body that would be evident externally. The "motricity" of Seurat's spectator is closely related to Christian Metz's account of the filmic spectator for whom the "institutional situation of the spectacle inherently prevents motor conduct from following its normal course very far." For Metz, the conditions of attentive filmic spectatorship are related to both dreaming and sleep in that motor activity, instead of being directed out into the world, has "a greater tendency to flow back towards the perceptual outlet. . . . It will turn back in the direction of the perceptual agency, to take the regressive path, to busy itself with hypercathecting perception from within." Metz, *The Imaginary Signifier*, trans. Celia Britton et al. (Bloomington: Indiana University Press, 1982), pp. 116–118.

61. Nietzsche, *The Will to Power*, p. 420; emphasis in original.

particular and shifting balance of physical responses within each individual observer? And was part of that free play the production of “intensified life, an enhancement of the feeling of life”?⁶²



Alongside the hypothetical individual observer who is the object of Seurat’s method, *Parade de cirque* contains a schematic figuration of a collective subjectivity, seemingly characterized by automatic behavior and whose attentiveness is inseparable from the vacancy of spectacle. In this sense the onlookers at the bottom of the painting are much more than simply pictorial surrogates for an external spectator; they stand here as potential objects of techniques for the control and management of perception and attention. Most of Seurat’s major works make this clear: how a sensory world is dismantled, resynthesized, and represented is inseparable from the problem of how a world of objects, individuals, and social relations organizes itself. His paintings are collections of hypotheses about how elements or things can be combined, of how various aggregates are produced (or dissolved) by different formal operations. What concerns Seurat, whether in terms of individual touches of color or images of human figures, is a tension between cohesion and disintegration. This is evident whether it is a question of how diverse stimuli become tentatively “bound” into a coherent constellation or how contents referring to a social world are fused or integrated into a network of relations. The effectiveness of *Parade de cirque* is inseparable from the movement between these two diagrammatic levels.

Seurat was one of many at this time whose work investigated the connection between the relative unity of subjective experience and the integrity of social institutions and processes. For figures like Charles Henry and Charles Fere, the phenomena of reflex responses and the operation of the nervous system were hardly just a matter of physiological knowledge. The paramount consideration was the maintenance of social order and equilibrium, and an excess of sensory stimulation was potentially disruptive or pathological. Thus for Henry and others, a scientific aesthetic suggested the possibility of producing “agreeable” nervous and psychic states compatible with social tranquillity and economic productivity. Fere was one of many preoccupied with the contemporary social fantasy of “solidarity,” and he cautioned against the dangers of collective overstimulation, sociopathic exhaustion and ultimately of degeneration, which threatened the health and functional

62. Ibid., p. 422 (sec. 802).

unity of solidarity.⁶³ Another influential figure in these issues was Jean-Marie Guyau, who in the late 1880s studied how the physiological nature of individual perception affected the functioning of social collectivities. Féré in fact cited Guyau's work as confirmation of the social significance of a dynamogenic explanation of aesthetic pleasure: for Féré and many others, individual pleasure ought not to exceed limits beyond which the long-term evolutionary interest of the collectivity were threatened.⁶⁴ Recent scholarship has shown how a significant body of French aesthetic theory, beginning in the 1880s and throughout the 1890s, increasingly addressed the nature of mass subjectivity and the relation between aesthetic perception and social integration.⁶⁵

Seurat, then, was working within a set of ideas that were as much social in their resonance as they were either "physiological" or aesthetic. But it would be a major misunderstanding to suggest that his work is part of a calculated project of producing "agreeable" psychic states in his spectators in the interests of social cohesion. Perhaps it would be more useful to consider that Seurat's balancing of dynamogenic and inhibitory effects in *Parade de cirque* produced, at least in theory, a harmonious equilibrium of psycho-kinesthetic response that was in some way a utopian projection of a sensory wholeness and fulfillment impossible within the dissonance of contemporary European culture. Certainly much of his work from Port-en-Bessin and Gravelines seems aligned with such a possibility: the finely ordered harbor scenes, with their evocation of a premodern relation of nature and culture, might have some visionary social potency.⁶⁶ But even if there is

63. In 1894 Henry declared, "That which science can and must do is to expand the agreeable within and outside of us, and from this point of view its social function is immense in this time of oppression and senseless conflict." Cited in Arguelles, *Charles Henry and the Formation of a Psycho-physical Aesthetic*, p. 84. See Charles Féré, "Degenerescence et criminalité," *Revue philosophique* 24 (October 1887), p. 357: "The need for excitement increases inversely to the weakening of the individual or race. Each new excitation is followed by a proportional quantity of exhaustion, of a sort which in the end precipitates degeneration."

64. See Jean-Marie Guyau, *L'art au point de vue sociologique* (Paris: Félix Alcan, 1889). Féré quotes Guyau in his *Sensation et mouvement*, p. 69. Nietzsche was familiar with some of Guyau's work from the early 1880s and was obviously interested in his assertion that the highest life is about feelings of abundance, strength, and "expansibilité," as well as his affirmation that instinct is more powerful than consciousness. On Nietzsche's reading of Guyau, see the study by the latter's stepfather, Alfred Fouillee, *Nietzsche et l'immoralisme* (Paris: F. Alcan, 1902).

65. See Nina Lara Rosenblatt, "Photogenic Neurasthenia," *October* 86 (Fall 1998), pp. 47–62.

66. These harbor paintings by Seurat, taken in this way, recall the remarks by Claude Lévi-Strauss on the eighteenth-century seaport paintings of Joseph Vernet: "For me, their value lies in the fact that they allow me to relive the relationship between sea and land which still existed at that time; a port was a human settlement which did not completely destroy, but rather gave a pattern to, the natural relationships between geology, geography and vegetation and thus offered an exceptional kind of reality, a

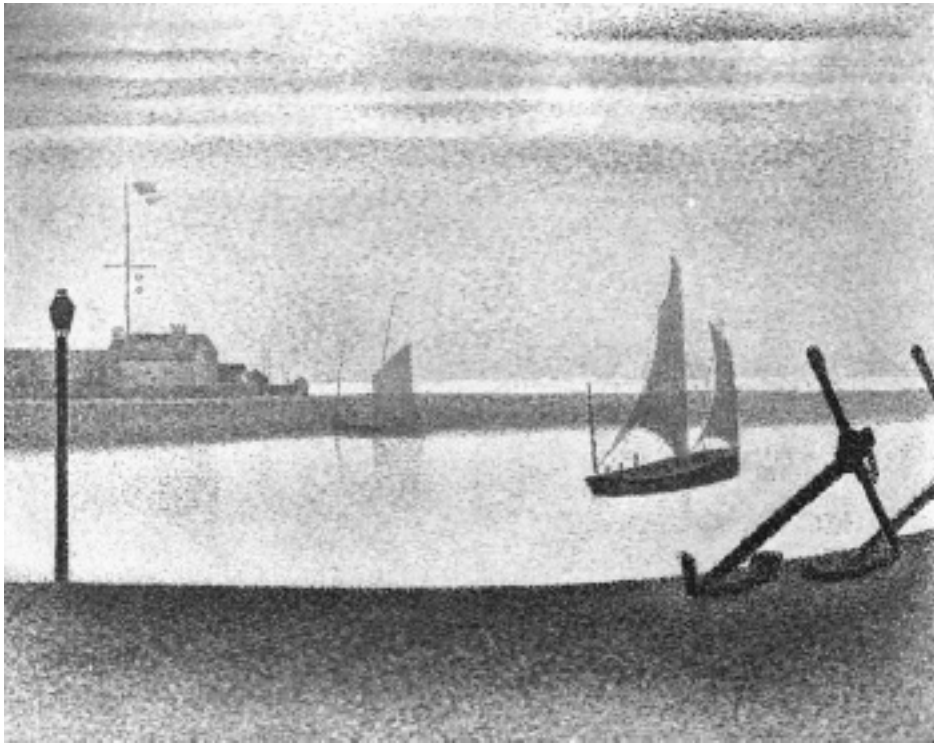

Georges Seurat, *The Channel at Gravelines, Evening*, 1890.

value in such an explanation, it cannot be reconciled with the problem of how the research on which Seurat relied was also fully part of institutional knowledge directed at the external control of subjective behavior and response. Nor does it suggest why such a figuration of harmony (“the analogy of opposites”) would overlap with the plainly ambiguous and even disturbing social content in *Parade de cirque* (and in *Cirque* as well).

This movement between the sensory and the social has affinities with the work of Seurat’s almost exact contemporary Emile Durkheim. No matter how ap-

dream world in which we can find refuge.” *Conversations with Claude Lévi-Strauss*, ed. G. Charbonnier, trans. John and Doreen Weightman (London: Grossman, 1969), p. 97. However, the rigorously depopulated ambience of Seurat’s paintings works against this reading. His one seaport image that includes human figures, *Port-en-Bessin: Le pont et les quais* (1888), is haunting for the starkness with which social isolation and distance is mapped out. See my remarks on these late marine paintings in my “Seurat’s Modernity,” in Ellen W. Lee, ed., *Seurat at Gravelines: The Last Landscapes* (Indianapolis: Indianapolis Museum of Art, 1990), pp. 61–65.

parently dissimilar their fields, both Seurat and Durkheim are related fabricators of powerful *imaginary* social figurations. They share a belief not only that science is a form of perception but that scientific procedures provide methods for the creation of new concepts and forms, and they stand for a shift in thinking from the study of elementary units to their rules of combination.⁶⁷ Both investigate how social and sensory elements combine or interact to form different sorts of aggregates, and both are concerned with how various syntheses produce *qualitative* transformations of the elements in question, whether these are social representations or sensory impressions. For both, it is a question of from what viewpoints significant manifestations of *organization* become apprehensible.

These questions, in relation to Seurat, are hardly new, and critics beginning with Meyer Schapiro and Ernst Bloch have looked at his paintings in these terms, evaluating the nature of the social aggregates that he assembles.⁶⁸ His handful of major works, including *La Grande Jatte* and *Cirque*, are diagrams of different kinds of social cohesion or dissolution, depending on one's political vantage point. *La Grande Jatte*, in particular, can be seen as an ambiguous puzzle, in Durkheimian terms, of the problematic nature of social *association*. Is the assemblage pictured here an image of harmony, to use a word privileged by both Durkheim and Seurat, the near-equilibrium state of solidarity, of individuals transformed into "social beings"? Or is it a statistical distribution of isolated and categorized units, the result of a merely additive principle of formal adjacency, in which depleted, anomic relations predominate beneath the spurious appearance of social concord?

67. Durkheim's own account of perception in the early 1890s shared some essential features with Seurat's dualistic dynamic model. Durkheim writes: "Every strong state of the consciousness is a source of life; it is an essential factor in our general vitality. Consequently all that tends to weaken it diminishes and depresses us. . . . In fact, a representation is not a simple image of reality, a motionless shadow projected into us by things. It is rather a force that stirs up around us a whole whirlwind of organic and psychological phenomena. Not only does the nervous current that accompanies the formation of ideas flow within the cortical centers around the point where it originated, passing from one plexus to another, but it also vibrates within the motor centers, where it determines our movements and within the sensorial centers where it evokes images." Durkheim, *The Division of Labor in Society* (1893), trans. W. D. Halls (New York: Free Press, 1894), p. 53. On science as a form of perception, see Paul Q. Hirst, *Durkheim, Bernard, and Epistemology* (London: Routledge and Kegan Paul, 1975), p. 104. For a recent discussion of Durkheim and perception, see Chris Jencks, "Durkheim's Double Vision," in Ian Heywood and Barry Sandywell, eds., *Interpreting Visual Culture: Explorations in the Hermeneutics of the Visual* (New York: Routledge, 1998), pp. 57–73.

68. See Meyer Schapiro, "Seurat and 'La Grande Jatte,'" *Columbia Review* 17 (November 1935), pp. 9–16; and Ernst Bloch, *The Principle of Hope*, vol. 2, trans. Neville Plaice et al. (Cambridge: MIT Press, 1986), pp. 813–817. See also Linda Nochlin, "Seurat's Grande Jatte: An Anti-Utopian Allegory," and Stephen F. Eisenman, "Seeing Seurat Politically," both in *Art Institute of Chicago Museum Studies* 14, no. 2 (1989), pp. 133–154 and 211–222; and T. J. Clark, *The Painting of Modern Life* (Princeton: Princeton University Press, 1984), pp. 263–267.



Georges Seurat, *Sunday Afternoon on the Island of La Grande Jatte*, 1884–1886.

Durkheim, in the 1890s, was concerned with new holistic models of association that would supersede those inflexible models of increasingly outdated associationist theories. His work entails a rejection of mere juxtaposition, and it poses synthesis as a dynamic and self-organizing process. It would not be unwarranted to link aspects of Durkheim's thought with early Gestalt theory: "A whole is not identical with the sum of its parts. It is something different and its properties differ from those of its component parts. . . . On the contrary, [association] is the source of all the innovations which have been produced successively in the course of the general evolution of things."⁶⁹ He developed analogies between physiological perception and the perception of social objects, insisting that each level was directed toward aggregates and wholes rather than atomized elements.⁷⁰ Durkheim's

69. Emile Durkheim, *The Rules of Sociological Method* (1895), trans. Sarah Solovay and John Mueller (New York: Free Press, 1964), pp. 102–103.

70. This is the central theme of his essay "Individual and Collective Representations" (1898), in which Durkheim engages the work of Janet, Wundt, and especially William James; in Durkheim, *Sociology and Philosophy*, trans. D. F. Pocock (Glencoe, Ill.: Free Press, 1953), p. 30: "The whole is only formed by the grouping of the parts, and this grouping does not take place suddenly as the result of a miracle. There is an infinite series of intermediaries between the state of pure isolation and the completed state

method involved a reorientation of attention, away from isolated or individual units toward the apprehension of larger aggregates, and his rejection of a psychology of individuals in favor of a “science of society” is implicit in this shift.

For Durkheim modernity is a qualitatively new phase in the history of human existence, but what specifically distinguishes it is the emergence of new kinds of human aggregates, in a sense new manifestations of complexity.⁷¹ Durkheim attempts, as Seurat in his own fashion also does, to characterize modern forms of social cohesion—by asking what it is that holds together the diverse elements of a society given the absence of relatively inflexible traditional forms such as religion, myth, and consanguinity. The answers to this question are inseparable from the way in which both *Parade de cirque* and *Cirque* are historically meaningful. “Organic solidarity” has the flexibility of a living system (in contrast to the “mechanical solidarity” of traditional society) in which vast numbers of differentiated individuals, composing many subsystems, cohere into one intricately functioning organism. Alienation and isolation are overcome by individuals understanding their necessary integration into self-regulating, interlocking feedback loops. Yet Durkheim’s work presents a fraudulently harmonious vision of industrialized society when high capitalism was taking shape in the late nineteenth century, and it attempts to validate a relatively stable and domesticated image of the dynamism and destructiveness of capital. Although insisting on growth and development as fundamental features of a social organism, Durkheim’s account of modernity is about a state of “equilibrium.” His postulation of the “organic solidarity” of modernity was just such a state of harmonious equilibrium in which, through legal rules, social conventions, professional organizations, and ultimately the state, human beings interact in relations of agreement and mutual sacrifice, a stable temporal order that Auguste Comte had earlier begun to outline. As François Ewald has shown, the

of association. But as the association is formed it gives birth to phenomena which do not derive directly from the nature of the associated elements, and the more elements involved and the more powerful their synthesis, then the more marked is this partial independence.” Recently it has been noted that “this whole essay underlines the great interest Durkheim took in the debates and developments in psychology in the 1890s; indeed that he taught courses in psychology at Bordeaux is often forgotten or overlooked. Far from adopting ‘crude’ or ‘naive’ views on the nature of the individual, Durkheim’s position was abreast of the major developments at the decisive moment of the formation of modern psychology.” Mike Gane, *On Durkheim’s Rules of Sociological Method* (New York: Routledge, 1988), p. 31.

71. Some of Durkheim’s “organicist” formulations (i.e., positing a continuity between biological and social entities) seem less retrograde than they might have several decades ago. His description of the evolution of human societies is very much as a self-organizing process, defined by threshold moments in which constellations of previously disconnected elements unexpectedly begin to interact to form a new higher-level entity or organism. This is especially the case in his account of the shift from the segmented societies characterized by “mechanical solidarity.”

notion of “solidarity” implied a new set of moral imperatives, the duty to become a “social being,” to become *socialized* in relation to a wide range of institutions.⁷²

In the 1890s Durkheim sought to explain how the division of labor which he believed essential to social vitality and moral order could at the same time be the cause of dissipative and pathological effects. The division of labor was a process that could not “be pushed too far without being a source of disintegration.”⁷³ Durkheim returned to Comte for a vocabulary to elaborate the effects of anomie—decomposition, dispersion, dissolution—all of which describe how certain patterns and networks of social organization are disrupted.⁷⁴ Anomie, in this sense, is a *formal* concept. That is, anomie designates a breakdown of an organized set of connections and adjacencies and deranges a normally regulated flow of communication and feedback. “A state of anomie is impossible wherever organs solidly linked to one another are in sufficient contact.” Durkheim insisted that “if the division of labor does not produce solidarity it is because the relationships between the organs are not regulated.”⁷⁵ Anomie, in a celebrated passage, is when the individual worker “is no longer the living cell of a living organism, moved by continual contact with neighboring cells, which acts upon them and responds in turn to their action, extends itself, contracts, yields and is transformed according to the needs of the circumstances. He is no more than a lifeless cog, which an external force sets in motion and impels always in the same direction and in the same fashion.”⁷⁶

Of course Durkheim tried hard to portray such social dissolution as part of a *transitional* phase, rather than as a permanent feature of a system that would, by its very nature, always be in transition. Because the transformations of modernization had occurred with such rapidity, “the conflicting interests have not had time to strike an equilibrium.”⁷⁷ His model of modern organic solidarity is linked both

72. See François Ewald, *L'Etat providence* (Paris: Grasset, 1986), pp. 364–367. Charles Fere, for example, had written in 1887: “A society can have no other durable foundation than solidarity.” Fere, “Degenerescence et criminalite,” p. 337.

73. Durkheim, *The Division of Labor in Society*, p. 294.

74. *Ibid.*, p. 295. Jean Duvignaud emphasizes the creative possibilities that are opened up by states of anomie: “The facts of anomie constitute a passage from one phase to another, from the systematic structure of language to a condition of non-structure that momentarily abolishes all established congruence and opens up a chasm, an illumination at the heart of established discourses. And this is independent of the disorder that inevitably provokes the collision, confusion and short-circuiting between different languages and series.” Duvignaud, *L'anomie: Heresie et subversion* (Paris: Editions Anthropos, 1973), p. 86.

75. Durkheim, *The Division of Labor in Society*, p. 304.

76. *Ibid.*, pp. 306–307.

77. *Ibid.*, p. 306.



Georges Seurat, Solitary Figure, 1883.

to the healthy complexity of a higher organism and to the near-equilibrium of a thermodynamic system. Within a thermodynamic framework, anomie and solidarity can be posed as two different kinds of statistical information about large aggregates of elements. Just as James Clerk Maxwell rejected a dynamical or “historical” account of the activity of individual molecules, so Durkheim renounced the individual as a unit of study in favor of collective regularities.⁷⁸ Anomie then describes a statistical distribution of elements in which insufficient contact or adjacency prevents the flow of messages or information within the system as a whole.⁷⁹ Without pushing this comparison too far or developing the homologies between anomie and entropy, it could be said that Durkheim saw the transmission of messages as

78. See P. M. Harman, *Energy, Force and Matter: The Conceptual Development of Nineteenth Century Physics* (Cambridge: Cambridge University Press, 1982), pp. 131–134.

79. This general formulation recurs throughout the twentieth century; for example, in the urban thinking of Christopher Alexander: “In any organized object, extreme compartmentalization and the dissociation of internal elements are the first signs of coming destruction. In a society, dissociation is anarchy. In a person, dissociation is the mark of schizophrenia and impending suicide.” Alexander, “A City Is Not a Tree, Part 2,” *Architectural Forum* 122, no. 2 (May 1965), p. 61.

a measure of the relative organization or disorganization of society.⁸⁰ If anomie, as a systemwide increase in local zones of dissociation and disintegration, is related to a failure of feedback processes, the anomic individual, described above, closely resembles in its functioning an automaton, in which the resilient adaptability of a living organism is supplanted by the repetitive pattern of machinic behavior.⁸¹ It is here that modern forms of attention, isolating and quasi-automatic, are intertwined with what Durkheim sought to explain as “anomie.”

Durkheim’s diagnosis of a crisis of social “disaggregation” reinforced his preoccupation with forms of binding and cohesion, just as Pierre Janet and others were studying psychic disaggregation and the mechanisms of cognitive and perceptual synthesis. But Durkheim’s palatable vision of a smoothly functioning (future) society of individuals working cooperatively within state-dominated corporate entities had little to do with the actual pseudo-solidarities that were taking shape in those years. Behind this phase of Durkheim’s work was the need to conceal or repress the omnipresent separations and segmentations produced by modernization.⁸² In a certain way Durkheim’s claim that he is writing about a crisis of social cohesion within a transitional period was correct, but one of the actual systemic responses to this crisis was only just taking shape within his lifetime (a response we see foreshadowed in several of Seurat’s major works)—the making of a society whose effective unity was founded on the ubiquity of spectacular consumption through mass media and technologies of illusion. If religion was the key “collective representation” within Durkheim’s premodern mechanical solidarity, the spectacle, as “a specious form of the sacred,” was to become the primary simulation of cohesion and unification within twentieth-century modernity.⁸³ De-

80. Traditional accounts of Durkheim often conflate the ethical and economic effects of “message transmission,” thus naturalizing the intensification of circulation under capitalism. See, for example, Raymond Aron, *Main Currents in Sociological Thought*, vol. 2, trans. Richard Howard and Helen Weaver (New York: Basic Books, 1967), p. 23: “Moral density, it seems to me, is roughly the intensity of communication between individuals, the intensity of intercourse. The more communication there is between individuals, the more they work together, the more trade or competition they have with one another, the greater the density.”

81. On the relation between organism and automaton, see Norbert Wiener, *The Human Use of Human Beings: Cybernetics and Society*, 2d ed. (Garden City, N.Y.: Doubleday, 1954), pp. 25–36.

82. According to Michel Foucault, Durkheim’s thought does not admit the existence of social mechanisms of *exclusion*. Durkheim’s sociology can only ask: “How can society hold individuals together? What is the form of relationship, of symbolic or affective communication that is established among individuals? What is the organizational system which permits society to constitute a totality?” “Michel Foucault on Attica: An Interview,” *Telos* 19 (1974), p. 156.

83. Debord, *The Society of the Spectacle*, p. 20. See Daniel Dayan and Elihu Katz, “Articulating Consensus: The Ritual and Rhetoric of Media Events,” in Jeffrey C. Alexander, ed., *Durkheimian Sociology: Cultural Studies* (Cambridge: Cambridge University Press, 1988), pp. 161–186.



Georges Seurat, Place de la Concorde, Winter, 1882-1883.

bord's *Society of the Spectacle* can stand for the final implosion and dismantling in the 1960s of the sociological tradition that issued from Durkheim, in Debord's insistence that the only solidarity produced by capitalism is a unity of subjects in their very separateness.

Surveying Seurat's entire visual output, both paintings and the much larger body of drawings (especially ones that are not obviously studies for larger works), it is impossible not to be struck by the endless and even systematic movement between the large engineered representations of social collectivities (or crowds) and the far more numerous images of isolation and separation. In the same way that the unity of his optical aggregates was always an ephemeral subjective construction that never objectively modified the abstract and segmented status of his dots, so his assembling of provisional social aggregates never alters the obdurately insular character of their individual human components. But even if Seurat's "sociology" is embedded within certain technical and rule-governed procedures, he nonetheless stakes out a darker and more skeptical position than Durkheim about

the possibility of positive knowledge of “social reality.” Thus, more than representations of anomie or class conflict, his works are determined by a sense of the impalpability and evanescence of the social itself.

As many have suggested, the emergence in the 1890s of a “science” of sociology, especially in France, is a sublation of the great social catastrophes of the nineteenth century and a compensatory product of the accumulated bourgeois anxiety over the disorders of the Revolution, the events of 1848, the 1871 Commune, and other upheavals. Seurat’s response to this legacy of turmoil is disturbingly revealed in a drawing from around 1883, *Place de la Concorde, Winter*. Here this bleak depopulated night world becomes a piercing negative image of the revolution so closely associated with this Parisian site. No architectural facades are visible amid the wintry desolation, and the actual obelisk at the center of this urban space, with all its mnemonic resonances, is decisively excluded from view. Instead, the banality of a lamppost anchors the scene, and only a partial silhouette of one of the two Hittorff fountains, at the left of the drawing, suggests the north-south axis on which the monumental obelisk stands. The carriage at the right, a ubiquitous fiacre, with its physical separation of driver and passenger, marks the class division on which the unbearable emptiness of the scene is founded. *Place de la Concorde* discloses the actual nightmare, the disorientation of a present in which the collective dreams of *egalite*, of *bonheur*, can no longer even be remembered. A decade or more after the Commune, it is not only a question of the repression of a field of hopes and anticipations but of the evacuation of the terrain on which they might once have been symbolically enacted.⁸⁴ *Place de la Concorde* points back to an earlier model of political theater, which is displaced by the modernized forms of spectacle that emerge in the last years of Seurat’s brief life.⁸⁵



The conceptual, technical, and representational strategies of Seurat’s late work are anticipations of the objects and forces that would become key compo-

84. See Denis Hollier, *Against Architecture*, trans. Betsy Wing (Cambridge: MIT Press, 1989), p. xxii: “For the first half of the nineteenth century, this esplanade was a source of uneasiness for developers and city planners. Should it be made into a place of memory and expiation or one of laughter and forgetting? How should one walk, with what sort of tread, where blood—including the king’s—had run? Taking advantage of this indecision, fairs and festivals temporarily set themselves up on this quasi-wasteland.” See also the account of the tangled symbolic uses of the Place de la Concorde during the Second Empire, in Matthew Truesdell, *Spectacular Politics: Louis-Napoleon Bonaparte and the Fete Imperiale, 1849–1870* (Oxford: Oxford University Press, 1997), pp. 17–26.

85. See the discussion of “theatrical depoliticization” in Andrew Hewitt, *Fascist Modernism: Aesthetics, Politics, and the Avant-Garde* (Stanford: Stanford University Press, 1993), pp. 164–172.



Georges Seurat, *Parade de cirque*, 1887–1888.

nents of new operations of social power in the early twentieth century.⁸⁶ Seurat discloses ways in which individuals, in their status and capacities as observers, can be assembled into new pseudo-solidarities, whether as crowds or audiences, even while maintaining their effective isolation. The painting reiterates on the level of content what it produces through its technical system: the work is a solicitation of attention. The sideshow, with its musicians and performers, is a device of *attraction*, meant to focus the attention of urban strollers and to persuade them to buy a ticket for access to the “main” attraction in the tent in front of them. But it is an attraction that will forever be withheld from them, from us, for this is a painting fundamentally designed around the cancellation and suspension of what it

86. On Debord and the “origins” of the society of the spectacle, see my “Spectacle, Attention and Counter-memory,” *October* 50 (Fall 1989), pp. 97–107.



Photograph of circus tent with sideshow platform, Paris, late 1880s.

promises to reveal. The spectator of this painting, both as individual and as part of a collective subjectivity, is inescapably implicated in its perpetual play of attraction and absence.

One of the most important features of *Parade de cirque* is how its formal organization destabilizes the position and identity of its presumed spectator. At the heart of this organization is Seurat's obliteration of the *scenographic* conditions of the work even as he simulates their persistence. The ostensible subject of the work is potentially *scenic* in more than one way: not only does it show a quasi-theatrical performance, but it positions its viewer as part of an audience before an apparently stagelike space.⁸⁷ It mimics a classically represented theatrical space while in fact withholding the essential elements of that signifying model: a model which, in principle, establishes an illusory world extending away from the spectator at the divide of the proscenium, yet a world reciprocally related to the viewer's own point of view. One of the most obvious structural features of *Parade de cirque* is the radical elimination of orthogonals and the resultant breakup of the painting

87. One of the exemplary accounts of the "cubical, unitary framework of classical scenography" in Renaissance painting is in the work of Pierre Francastel. See, for example, his *Etudes de sociologie de l'art: Creation picturale et société* (Paris: Denoel, 1970), pp. 191–197.

F. 12.

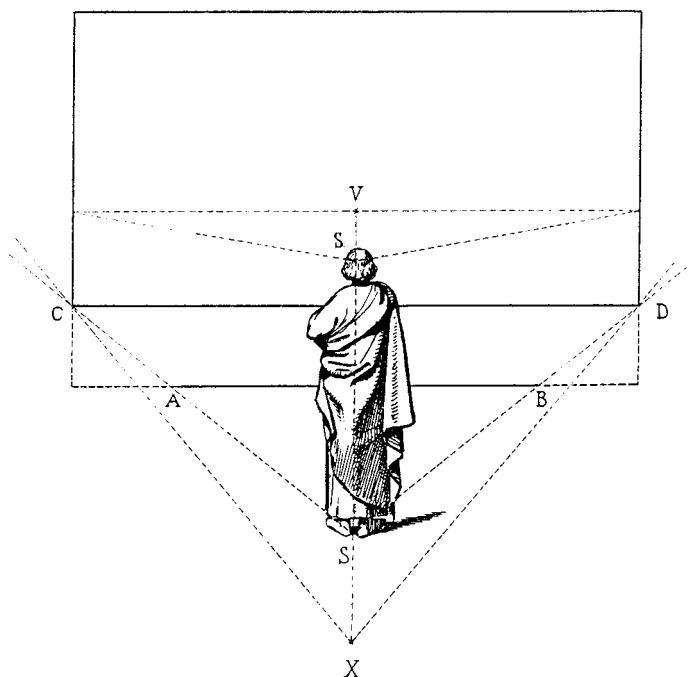

Illustration from David Sutter, *Nouvelle théorie simplifiée de la perspective*, 1859.

into an assemblage of disjunct planar elements.⁸⁸ Seurat's refusal of any orthogonal guides, of almost any foreshortening or recession indicators to aid us in construing spatial relations within the painting, has the effect of collapsing the "stage" area above the spectators into a single patchwork screen and of dramatically sealing off possible avenues of entry into the work for our eye. It is as if, in *Parade de cirque*, he simulated David Sutter's 1859 diagram of the perspectival relation between spectator and a rectangular tableau, but obliterated the determinate system of orthogonals on which its intelligibility depended.⁸⁹ At the same time this formal decision prevents the appearance of any planes or surfaces perpendicular to the picture plane. Thus we are denied one of the key elements that determined the

88. I have discussed certain forms of nineteenth-century imagery as aggregates of dissociated planar elements, in particular the stereoscope, in my *Techniques of the Observer: On Vision and Modernity in the Nineteenth Century* (Cambridge: MIT Press, 1990), pp. 124–126.

89. Sutter, *Nouvelle théorie simplifiée de la perspective*.

coherence of classical scenography: we cannot see the literal location of figures on the surface of the stage or on the “checkerboard” ground of perspectival painting. None of the figures in *Parade de cirque* are “grounded” in any visibly legible way. This is especially true of the central trombone player, whose feet are disturbingly hidden from view.

One of the very few elements in the painting that recall a transversal of classical representation is the diagonal line at the lower center of the work, behind the trombone player. It represents the bannister of a stairway leading up from street level allowing access to the interior of the circus. The entryway into the unseen interior is situated, from our point of view, where two flat planes seem to abut each other on the same surface just to the right of the central figure, effectively negating the possibility of a visual “entrance” from our point of view. This diagonal, as a residual fragment of a lost schema of transversals, is redeployed as a unit of a surface, characterized not so much by flatness as by impenetrability and opacity. The surface becomes a *tabular* field with rows and columns, making impossible a punctual, or point to point, relation between spectator and image.⁹⁰ At issue here is the subversion of the essential expectations of a classical theatrical plan: the collapsing of depth and the closing off of the very site to which the sideshow beckons us. *Parade de cirque*, then, hovers ambiguously between two scopic regimes, to use Martin Jay’s phrase: between the metric and homogeneous tableau loosely synonymous with classical space, and a decentered and destabilized perceptual regime with its mobile and embodied observer.⁹¹ The evocation of a scenographic setup is a veil over the dissociated, nonhomogeneous, and additive

90. For a concise account of the significance of the point, and of punctuality, within classical epistemology, see Michel Serres, *La distribution* (Paris: Minuit, 1977), pp. 17–28. See also the discussion of punctual systems in art in Gilles Deleuze and Felix Guattari, *A Thousand Plateaus: Capitalism and Schizophrenia*, trans. Brian Massumi (Minneapolis: University of Minnesota Press, 1987), pp. 294–298. Jacques Derrida discusses Husserl’s phenomenology in terms of the punctuality of vision and the indivisibility of an experience of a pure temporal present, in *Speech and Phenomena, and Other Essays on Husserl’s Theory of Signs*, trans. David B. Allison (Evanston: Northwestern University Press, 1974), pp. 60–69. Because of the regularity with which *Parade de cirque* has been situated as an anticipation of twentieth-century flatness, I am reluctant to characterize it structurally as a “grid,” except in the terms of this problem discussed in Rosalind E. Krauss, *The Originality of the Avant-Garde and Other Modernist Myths* (Cambridge: MIT Press, 1985), pp. 13–17: “By its very abstraction, the grid conveyed one of the basic laws of knowledge—the separation of the perceptual screen from that of the “real” world. Given all of this, it is not surprising that the grid—as an emblem of the infrastructure of vision—should become an increasingly insistent and visible feature of neo-impressionist painting, as Seurat, Signac, Cross and Luce applied themselves to the lessons of physiological optics” (p. 15).

91. See the chapter on “The Crisis of the Ancien Scopic Regime,” in Martin Jay, *Downcast Eyes: The Denigration of Vision in Twentieth-Century French Thought* (Berkeley: University of California Press, 1993), and Jay, “Scopic Regimes of Modernity,” in Hal Foster, ed., *Vision and Visuality* (Seattle: Bay Press, 1988), pp. 3–28.

construction of the work.⁹² But this is not the same thing as saying that *Parade de cirque* is an anticipation of various twentieth-century manifestations of flatness in painting. Instead, one might associate this strategy with features of early cinema. Film historian Tom Gunning has argued convincingly that in spite of the frontality and unity of framing in so-called “primitive” cinema, this work has less to do with a perpetuation of theatrical traditions or the frame of the proscenium arch than it does with a countertradition of magical display and behind-the-scenes manipulation of optical appearances.⁹³ This closed-off, antiscentic space is also related to forms of popular display like shadow figures, puppet theaters, and other forms that only simulate or evoke the “cube” of a theatrical stage. In this sense the particular distribution of figures across this shallow space is a deliberate archaism, recalling less a friezelike model derived from classical antiquity than the processional organization of medieval religious theater and mystery plays.⁹⁴

Given what I’ve said about the antiscentographic character of *Parade de cirque*, I want briefly to compare it with a painting which for the nineteenth century was an exemplary model of those very scenographic values, and which also has a few significant affinities with the Seurat: Leonardo’s *Last Supper*.⁹⁵ I juxtapose these two works not simply because the *Last Supper* had long seemed to be a consummate demonstration of one-point perspective but also because of specific ways in which Seurat’s work, also a technical set piece, is a relentless, even satirical negation of the assumptions underpinning Leonardo’s work.⁹⁶ Also, it would be

92. Aspects of this disjunct organization of *Parade* were sensitively noted in Robert J. Goldwater, “Some Aspects of the Development of Seurat’s Style,” *Art Bulletin* 23 (June 1941), pp. 117–130.

93. See, for example, Tom Gunning, “Primitive Cinema: A Frame Up or the Trick’s on Us,” in Thomas Elsaesser, ed., *Early Cinema: Space, Frame, Narrative* (London: BFI, 1990), pp. 95–103.

94. See George R. Kernodle, *From Art to Theatre: Form and Convention in the Renaissance* (Chicago: University of Chicago Press, 1944), pp. 13–15. Kernodle’s text is discussed and qualified in Hubert Damisch, *The Origin of Perspective*, trans. John Goodman (Cambridge: MIT Press, 1994), pp. 394–401. Damisch notes the relatively brief historical existence of “a theater whose apparatus facilitated changes of scenery and spectacular effects, all the while satisfying, in an illusionist mode, the principle of unitary organization of the scenic space.” Robert Herbert associates *Parade de cirque* with the “processional isolation” of figures in Egyptian art, in his *Neo-Impressionism* (New York: Guggenheim Museum, 1968), p. 119.

95. It should be noted that nineteenth-century knowledge of the *Last Supper* had little to do with the actual disintegrating painting in Milan; instead, most critical response to the work was based on several widely known copies of the work, such as an engraving by Raphael Morghen or prints of the 1807 “reconstruction” by Giuseppe Bossi.

96. Mary Mathews Gedo has argued that Seurat’s interest in older art was concentrated heavily on great religious works, and she makes a case that “he conceived the *Grande Jatte* as a modern icon, the secular equivalent of a great religious altarpiece. . . . The religious aspects of the composition became increasingly important as the picture progressed, and by the time Seurat applied the topmost layer of

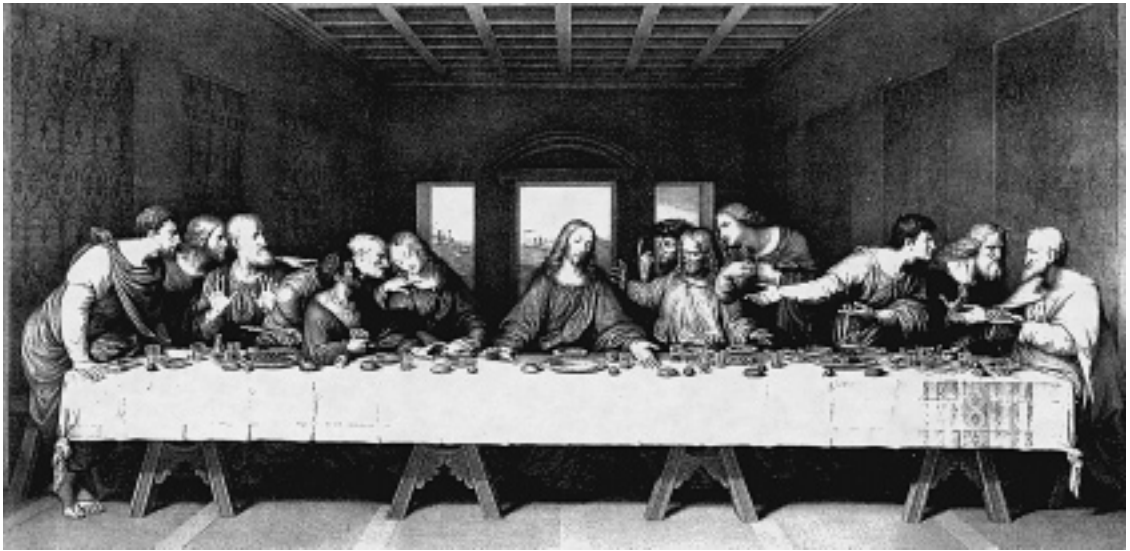

Raphael Morghen, engraving of Leonardo's *The Last Supper*, 1800.

difficult to consider more fully the relationship between art and science in the 1880s without some attention to the major revival and reorientation of interest in Leonardo beginning in that decade.⁹⁷ The point is not whether Seurat may have identified his own vocation as artist-scientist with that of Leonardo but that his own intellectual development paralleled the modern discovery of the full scope of Leonardo's interests (specifically the translations into French of his notebooks during the 1880s and a wide range of new analysis and commentary).⁹⁸ During these

Pointillist dots to the painting, each stroke had assumed the character of a ritualistic gesture imbued with a holy quality." Gedo, "The *Grande Jatte* as the Icon of a New Religion: A Psycho-Iconographic Interpretation," *Art Institute of Chicago Museum Studies* 14, no. 2 (1989), pp. 223–237.

97. *The Last Supper* is the first artwork discussed by David Sutter in his "Les phenomenes de la vision," *L'Art* (1880). This article was one of the few "sources" of his art theory that Seurat disclosed in his anxious 1890 letter to Feneon, where he is deeply concerned about the public record of his intellectual and aesthetic formation. Sutter's account of the *Last Supper* in terms of the relation between "le point de vue" and "les lignes fuyantes" (orthogonals) illustrates precisely what Seurat dismantles in *Parade de cirque*. Reiterating a comparison that had become formulaic by the mid-nineteenth century, Sutter contrasts Leonardo's painting with Veronese's more explicitly theatrical *Marriage at Cana* (1562); the latter is a work which, at least in its central section, can be affiliated with *Parade de cirque*, in that it is composed of compressed planes, such as railings and different architectural levels, whose spatial legibility is not clarified by any orthogonals. The *Last Supper* is also the primary work in the discussion of "point de vue" in Charles Blanc, *Grammaire des arts du dessin*, pp. 510–513. Blanc also uses the *Marriage at Cana* to exemplify an alternate pictorial organization, in which the unity of a single point of view and single horizon line is broken up.

98. Seurat's friend Charles Henry had been directly involved in some of the Leonardo translation and publication projects in the mid-1880s. Some influential work on Leonardo included Charles Ravaisson-

years Leonardo's cultural valence took on many conflicting forms that mirror some of the paradoxes of Seurat's own career. Certainly, Seurat would not have disagreed with Gabriel Seailles's 1888 paraphrase of Leonardo: "Art is not, as some imagine it, a mechanical or mere technical process; rather it is a mental thing, *cosa mentale*."⁹⁹

Each of these paintings, it could be said, concerns the revelation of a mystery: in one the mystery of Christian sacrifice as it coincides with a lucid apprehension of infinite extension; in the other, the making visible of the "mystery" of the disenchanted and quantitative order of capitalist exchange, and its overturning of both the homogeneity and legibility of space. As in the *Last Supper*, *Parade de cirque* has a row of thirteen figures stretching across a horizontal surface, but there is no redemptive figure in this grouping. Instead their attention, for the most part, seems casually dispersed among themselves and toward the sideshow performers. This motley crowd is witness not to holy communion but to rituals intrinsic to modernity. One of the key elements of *Parade de cirque* is the marginal vignette at the right side: we see two figures, perhaps a mother and daughter, buying tickets in order to attend the spectacle promoted by the musicians which is occurring, or about to occur, behind the backdrop that extends the length of the painting. There is a full correspondence here between the role of consumer and of attentive spectator. This relationship of exchange, this movement of abstract quantities exposes the *transactional* dimension of the work and makes the question of *value* central to its effects. The shallow little cashier's window, which is the only opening penetrating the planar screen behind the performers, is a sardonic reminder of a lost transparency, of the breakdown of the classical model of picture plane as window. One of Georg Simmel's early insights was how the uses of money within modernity transformed the social character of exchange from something interpersonal to an anonymous transaction, and to exchange at a

Mollien, "Les écrits de Leonard de Vinci," *Gazette des Beaux-Arts* 23 (1881), pp. 225ff, 331ff, 514ff; H. De Geymüller, "Derniers travaux sur Leonard de Vinci," *Gazette des Beaux-Arts* 34 (1886), pp. 143–164; Gabriel Seailles, *Leonard de Vinci: L'artiste et savant. Essai de biographie psychologique* (Paris: Perrin, 1892). One of the conclusions made by Ravaisson-Mollien concerns the centrality of geometrical proportions in Leonardo's thought: "He says, in effect, that proportion can be discovered not only in numbers and measurements but also in sounds, weights, time, locations, and in all kinds of forces" (p. 237). Earlier Hippolyte Taine, a close friend of Seurat's teacher Henri Lehmann, wrote on Leonardo with particular attention to the element of androgyny in his artwork, in "Leonard de Vinci" (1865), in Taine, *Derniers essais de critique et d'histoire* (Paris: Hachette, 1894), pp. 340–374. On the general cultural impact of Leonardo in late nineteenth-century France, see A. Richard Turner, *Inventing Leonardo* (New York: Knopf, 1992), pp. 132–149.

99. Gabriel Seailles, "Peintres contemporains: Puvis de Chavannes," *Revue bleue: revue politique et littéraire* 6 (February 11, 1888), p. 183.



Seurat, Parade de cirque, detail.

distance.¹⁰⁰ Seurat's depiction of the ticket seller's window becomes a concentrated image of the accumulated social experience of separation, of depersonalized exchange. Finally, that act of exchange is what supplants the miracle of transubstantiation in Leonardo's work: here it is the convertibility of any object, experience, or perception into a form of universal equivalence.¹⁰¹

100. Georg Simmel, *The Philosophy of Money* (1900), trans. Tom Bottomore and David Frisby (London: Routledge, 1978), pp. 297–303, 460–461. “The a priori equivalence of prices for all commodities will eliminate the numerous deliberations and examinations of the buyer, the numerous efforts and elucidations of the seller, so that the economic transaction will very quickly and indifferently pass through its personal channels” (p. 461). It should be remembered that Simmel began work on this project in the late 1880s, first publishing his paper “On the Psychology of Money” in 1889.

101. As Jean-Joseph Goux has shown, capitalism is a system in which “the libidinal, the intersubjective, and the semantic are completely divorced from economic relations, which are henceforth *uncovered* as such.” He describes a general “disaffection” of value, a draining away of the personalized and signifying dimensions of exchange and the emergence of a fully autonomous economic sector that resists seman-

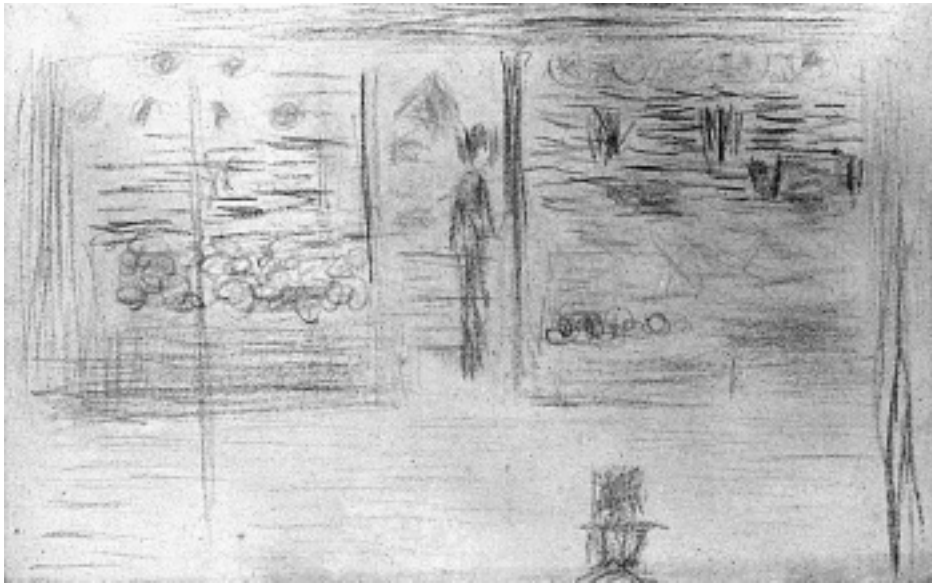

Georges Seurat, *A Shop and Two Figures*, c. 1882.

Five years or so earlier, Seurat had worked on a related image in which we also see the implied transparency of an apparent attraction, of a window, closed off to become an opaque luminous screen. This remarkable color drawing from around 1882, *A Shop and Two Figures*, has a general structural similarity to *Parade de cirque*. It too is “scenic” in that it is determined by the position of an observer, the head of a man, occupying the bottom of the frame like a single representative of the spectators in the later painting. He too is facing a plane composed of rectangular elements, which here are the facade and glass windows of a store. But Seurat withholds any legible information about the objects offered up for sale, and instead diagrams the formal conditions of exhibition and attraction in which the specific identity of the commodity form is irrelevant. Devoid of orthogonals, its symmetrical format is broken by the inclusion of a vertical on the left, much like the effect of the tree in *Parade de cirque*. I note this drawing as support for the idea that *Parade de cirque* is another (though obviously fully developed) meditation on the emptiness of a modern relation of display and consumption. *Parade de cirque* also represents the explicitly economic milieu of *A Shop and Two Figures*, the

tic or affective investment. Goux, *Symbolic Economies after Marx and Freud*, trans. Jennifer Gage (Ithaca: Cornell University Press, 1980), pp. 125–129.

ubiquity of the subjective experience of “shopping” and its construction as spectacle.¹⁰² The distribution of color in this drawing is especially interesting: the two figures, the window frames, and the sketchy indications of street and surrounding area are uniformly done in dark violet. The content of the shop windows, however, are fields of vivid color contrasts—of blue-yellow, of orange-blue—and touches of pure yellow. A stark opposition is thus set up between the monochromatic world of the street and spectators and the flickering multicolored screen of the windows themselves as bright zones of attraction.

If at the center of the *Last Supper* the head of Jesus is aligned with the vanishing point and central window opening onto infinite celestial space, what occupies the related area of *Parade de cirque* may be equally significant. This is the large sign indicating the cost of admission, at two different rates, in centimes, but it is partially obstructed by the central figure so that all we see of it are two zeros (and a fragment of the digit next to the upper zero, perhaps a “3” indicating 30 centimes). In its cancellation of any transcendent resonances, it is what might be called one of the vanishing points of modernity—the price tag exhibited in all its abstraction, the price tag as the draining away of the illusion of reference or stability.¹⁰³ It indicates a new limit of rationalization and disenchantment in art practice. The immobile appearance of the image is set off against the very process of circulation and convertibility that is represented. At the same time the simulation inherent in the literal spectacle is inseparable from the “semblance” which is the price tag. For Marx, the price is “the symbol of itself,” it is “only fleeting, a

102. It might be valuable, however, to consider the relation between the two figures: the figure at the lower right, clearly male, observes another of uncertain gender standing just beyond the threshold of the doorway to the shop. This arrangement has some of the structure of an early detective story: the covert surveillance of one individual by another. I mention this feature to associate it with such a narrative: Edgar Allan Poe’s “The Man of the Crowd,” in which the narrator trails a particular stranger “whithersoever he should go” and “so as not to attract his attention.” Although the tale was written around 1840, stores are a crucial part of this stranger’s itinerary: “At no moment did he see that I watched him. He entered shop after shop, priced nothing, spoke no word, and looked at all the objects with a vacant stare.” It is precisely that kind of vacant stare which becomes part of Seurat’s vision of the store windows here, and subsequently in *Parade de cirque*. Beyond this specific content, Poe’s brief text, in its paradigmatic articulation of modern loneliness, also corresponds to the proto-sociology informing Seurat’s oscillation between images of isolated figures and social collectivities. The narrator of Poe’s tale recounts how his “electrified” intellect “first took an abstract and generalizing turn. I looked at the passengers in masses, and thought of them in aggregate relations. Soon, however, I descended to details, and regarded with minute interest the innumerable varieties of figure, dress, air, gait, visage, and expression of countenance.” Edgar Allan Poe, *Poetry and Tales* (New York: Library of America, 1984), pp. 388–396. Charles Henry indicated the way in which Poe might well have been of interest to Seurat, as a poet who celebrated the importance of science, in his “Introduction a une esthetique scientifique,” *Revue contemporaine* (1885), p. 444.

103. A vanishing point in a perspectival construction has no necessary connection with the mathematical center of a painting.

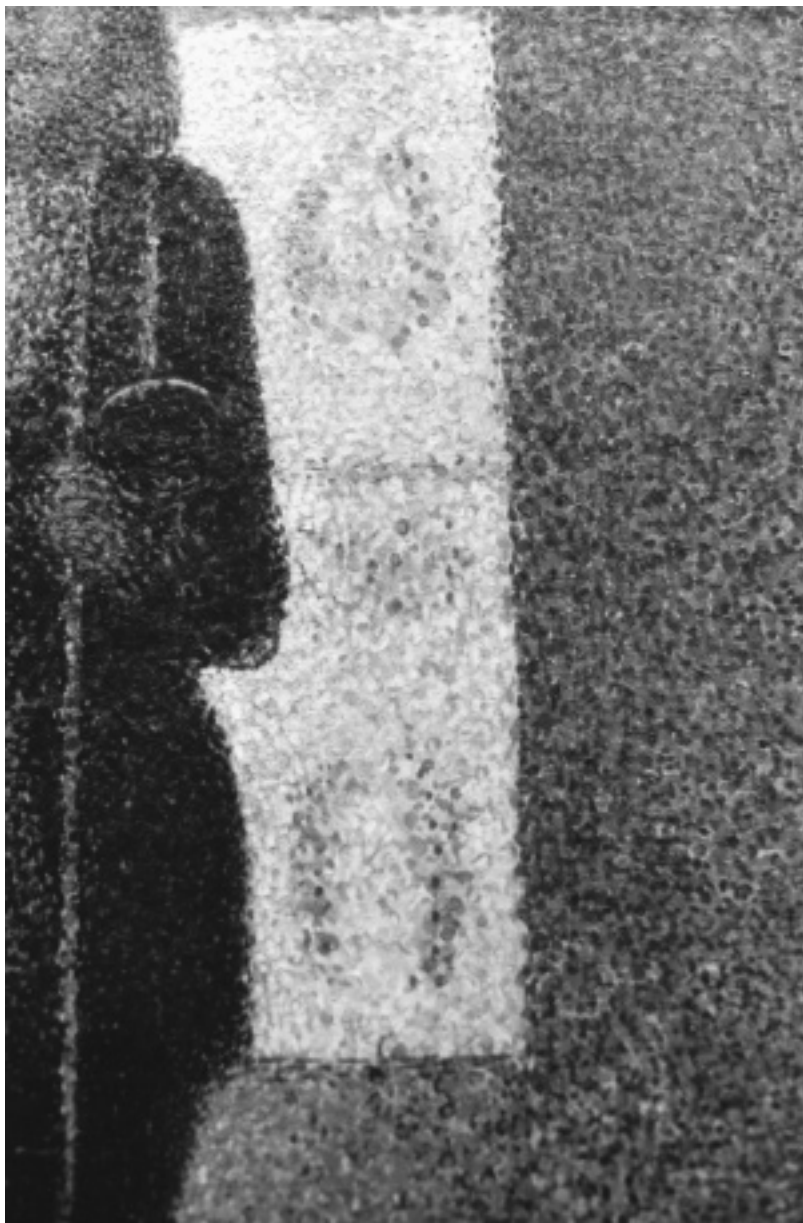

Seurat, *Parade de cirque*, detail.

reality destined constantly to disappear, to be suspended, not to count as a definitive realization but always only as an intermediate, mediating realization. . . . It exists, therefore, in so far as it remains in this constant movement . . . its reality is not that it is the price but that it *represents* it, is its representative—the materially present representative of the price, thus of itself, and as such, of the exchange value of commodities.”¹⁰⁴ The literal ambivalence of the price tag here in *Parade de cirque* becomes a key to a general problematizing of symbolic practices in the painting as a whole.¹⁰⁵ Whether it is color or money, Seurat situates his own practice within a regime of signs that are symbols of value rather than possessed of any intrinsic value themselves. It is within this problematic that his work is crucial to any consideration of the question of “symbolism” in late nineteenth-century culture.

In addition to being a price tag (in which the two digits hover as reminders of the stratified class character of consumption), it is also, and perhaps more importantly, a calculated positioning of the mathematical sign of zero at the core of the work. This placard declaring the price of admission (an admission which, as I have shown, is impossible visually) becomes a sign about a sign, a sign that assumes a crucial importance in the painting. Brian Rotman has indicated how it is the “double aspect of zero, as a sign inside the number system and as a meta-sign, a sign about signs outside it, that has allowed zero to serve as the site of an ambiguity between an empty character (whose covert mysterious quality survives in the connection between ‘ciphers’ and secret codes), and a character for emptiness, a symbol that signifies nothing.”¹⁰⁶ In the context of my reading of the work, it is difficult to avoid its essentially nihilistic force, its announcement of the vacancy and absence that suffuse the entire painting. Rotman argues convincingly that there is an isomorphism between the vanishing point in visual representation, the use of zero in computation, and abstract money in economic exchange as these forms emerge in the Renaissance. However, his account does not address Erwin

104. Karl Marx, *Grundrisse*, trans. Martin Nicolaus (New York: Random House, 1973), pp. 211–212.

105. Seurat’s preoccupation with the idea of the price is evident in his rationalization of the cost of his own artworks. See Schapiro, “Seurat and ‘La Grande Jatte,’” p. 16.

106. Brian Rotman, *Signifying Nothing: The Semiotics of Zero* (New York: St. Martin’s Press, 1987). See Sergei Eisenstein’s remarkable analysis of another painting from the late 1880s in which the presence of a “zero point” is the decisive element in a composition structured in terms of the golden section. Eisenstein insists that in Vasily Surikov’s *The Exile of the Boyarina Morozova* (1887) the viewer’s attention is deliberately directed to a point “that is the most important” but which is “unportrayable plastically.” Sergei Eisenstein, *Nonindifferent Nature*, trans. Herbert Marshall (Cambridge: Cambridge University Press, 1987), pp. 23–26. Surikov (1848–1916) was, like Seurat, a late nineteenth-century painter committed to exploring “the mathematics of painting.”

Panofsky's insistence that the vanishing point was a figuration of the coincidence of the transcendent and the empirical. Panofsky describes "true central perspective with its infinitely extended space centered in an arbitrarily assumed vanishing point" as resulting in "the concept of an infinity, an infinity not only prefigured in God, but indeed actually embodied in empirical reality."¹⁰⁷ *The Last Supper* is one of the clearest examples of Panofsky's claim that even though "perspective seals off religious art from the realm of the magical . . . it opens it to something entirely new: the realm of the visionary, where the miraculous becomes a direct experience of the beholder, in that the supernatural events in a sense erupt into his own, apparently natural visual space."¹⁰⁸

All of these effects of the vanishing point, of the orthogonals, of a postulated infinity are absent and nullified in *Parade de cirque* (even though they were still implicit in the loosely trapezoidal structure of *La Grande Jatte* or the quattrocento allusions in *Une baignade, Asnieres*).¹⁰⁹ If, according to many accounts, classical representation is a system of fixed relations in which subjectivity is imagined in terms of its coincidence with a quantifiable point of view, here we have a release from the binding order of that regime. But for Seurat it is always to be an ambivalent liberation, and the zeros disclose an organization of signs and values in which identity and reference are marginalized in favor of exchangeability and flux, an organization that also governs the molecular strata of the painting's composition.¹¹⁰ As Levi-Strauss and others have noted, zero effectively functions as a "floating signifier" even as it affirms the existence of the structure in which effectively

107. Erwin Panofsky, *Perspective as Symbolic Form* (1924), trans. Christopher S. Wood (New York: Zone Books, 1991), p. 65. This book also contains a detailed discussion of the Vitruvian account of scenography.

108. Panofsky, *Perspective as Symbolic Form*, p. 72. "Perspective, in transforming the *ousia* (reality) into *pbainomenon* (appearance), seems to reduce the divine to a mere subject matter for human consciousness; but for that very reason, conversely, it expands human consciousness into a vessel for the divine."

109. In Leo Steinberg's brilliant analysis of *The Last Supper*, "the trapezoid—the form produced wherever orthogonals meet a transversal—is the single most characteristic figure in fifteenth-century painting. For the Quattrocento painter building one-point perspective with rectilinear elements, it is the ineluctable modality of the visible. In the *Cenacolo* it is the form-giving cause, the visual principle that reconciles the phenomenal world with the manifestation of God." Steinberg, "Leonardo's Last Supper," *Art Quarterly* 36, no. 4 (1973), pp. 297–410.

110. Friedrich Engels, writing in the late 1870s, elaborated the usefulness of zero within the ongoing development of the sciences: "Zero, because it is the negation of any definite quantity, is not therefore devoid of content. On the contrary, zero has a very definite content. As the border line between all positive and negative magnitudes, as the sole really neutral number, which can be neither positive nor negative, it is not only a very definite number, but also is itself more important than all other numbers marked off from it. In fact, zero is richer in content than any other number." Engels, *Dialectics of Nature*, trans. Clemens Dutt (New York: International Publishers, 1940), p. 251.

“meaningless” signs circulate. In *Parade de cirque* this structure then still bears within it a locus for a transcendental signifier, but that place can now be occupied by a substitutional chain of empty signs. According to Kojin Karatani, “No matter how radical this reversal may be, it must be noted that the floating signifier, or zero sign, guarantees the structurality of structure and, thus, exists merely as a proxy for God or the transcendental ego.”¹¹¹ There is a reciprocal relationship between Seurat’s “dot” or atomized mark which in itself carries the meaning of sheer presence and nothing else, and these central graphic signs—loops, rings, circles—that depict absence through the division of space into an inside and outside.¹¹² Seurat notably refrains from displaying a single zero, which might have suggested a more primal image of nothingness, like the mystical letter of the Kabbalah, the egg, the Uroboros of other traditions. Instead, the doubling or repetition of the zero demystifies and disperses it within a logic of mechanical repeatability, like two successive frames of film or like the row of musicians at the left, arrayed as if indistinguishable workers on an assembly line. Within a system in which even nothingness can be duplicated, these signs cannot be the figuration of a point of origin. Also, it might be possible to think of the two zeros as potential components of the mathematical symbol for infinity (about which Charles Henry had already written) of two adjacent loops, a symbol here dismantled and dispersed into traces of its negation and loss, abandoning what Derrida calls “the positive plenitude of classical infinity.”¹¹³

The thematic of absence and exchange signaled by the zeros is inseparable from the overall content of the image: it is the evocation of a spectacle to which we are emphatically denied visual access but to which we are nonetheless attracted and enticed. Even the virtuality and abstraction of a vanishing point are negated.¹¹⁴ The painting is another disclosure of the irremediable vacancy that Mallarmé noted at the London exposition, and which is finally the primary object of

111. Kojin Karatani, *Architecture as Metaphor: Language, Number, Money*, trans. Sabu Kohso (Cambridge: MIT Press, 1995), p. 43. See also Claude Lévi-Strauss, “L’introduction à l’œuvre de Marcel Mauss,” in Marcel Mauss, *Sociologie et anthropologie* (Paris: Presses universitaires de France, 1950), pp. ix–lii; and Jacques Derrida, “Structure, Sign and Play in the Discourse of the Human Sciences,” in *Writing and Difference*, trans. Alan Bass (Chicago: University of Chicago Press, 1978), pp. 278–294.

112. Charles Henry wrote a two-part article in which he discussed the historical origins of various mathematical signs, including zero and the sign for infinity, in “Sur l’origine de quelques notations mathématiques,” *Revue archéologique* 37 (1878), pp. 324–333; 38 (1879), pp. 1–10.

113. See Jacques Derrida, “Violence and Metaphysics,” in *Writing and Difference*, pp. 112–113.

114. It should be remembered that Marshall McLuhan characterized Seurat’s work as a crucial historical threshold that “reversed traditional perspective by making the viewer the vanishing point,” in *Through the Vanishing Point: Space in Poetry and Painting* (New York: Harper and Row, 1968), pp. 24–25.

spectacular attentiveness. If the *Last Supper* symbolically opens onto a noumenal world, *Parade de cirque* obliterates that opening and replaces it with a facade of appearance and semblance. *Parade de cirque*, first exhibited while Nietzsche wrote his *Twilight of the Idols*, is also, on its own terms, a meditation on the evaporation of a true world, on its unknowability, its unattainability, its undemonstrability. Perhaps most significantly, *Parade de cirque* insists that the foreclosure of that true world is inseparable from the fragility and insubstantiality of the apparent world.¹¹⁵ At the same time it is a laying bare of the opacity and deception implicit in classical representation, of the obsolescence of the legible position presumably assigned to the observer by that system.¹¹⁶

Of course it is not just the zeros that are crucial to the operation of the work. The enigma of the central figure is important in this respect. For over a hundred years the model or source for this ominous trombone player has been consistently identified by art historians, critics, and others as premodern—whether Egyptian priest, medieval magus, Babylonian snake charmer, headsman or executioner, or other type of esoteric, cultic initiate or magician.¹¹⁷ In whatever imprecise way, then, this iconic and ambiguous figure has stood for a residue of an earlier social world in which the sacred, the occult, and artmaking were much more closely tied together but that survives merely as debasement or parody, the figure now a kind of clown. But the suggestion of magician also becomes emblematic of a modernized order of spectacle, of the mass management of attentiveness and its commodification. It is the rationalized magic of a technology of attraction that conceals its

115. See Nietzsche, *The Twilight of the Idols* (1889), in *The Twilight of the Idols; and, The Anti-Christ*, trans. R. J. Hollingdale (Harmondsworth: Penguin, 1968), pp. 40–41.

116. See Andre Green, “The Psycho-analytic Reading of Tragedy,” in Timothy Murray, ed., *Mimesis, Masochism, and Mime: The Politics of Theatricality in Contemporary French Thought* (Ann Arbor: University of Michigan Press, 1997), p. 138: “The theatrical space is bounded by the enclosure formed as a result of the double reversal created by the exchanges that unfold between the spectator and the spectacle, on either side of the stage. We may try to eliminate this edge; it is only reconstituted elsewhere. This is the invisible frontier where the spectator’s gaze meets a barrier that stops it and sends it back—the first reversal—to the onlooker, that is, to himself as source of the gaze.”

117. For example, the figure is likened to a headsman in John Russell, *Seurat* (New York: Praeger, 1965), p. 218; Richard Thompson suggests similarities with Rembrandt’s *Christ before Pilate* and its associations with impending execution and sacrifice in his *Seurat* (Oxford: Phaidon, 1985), p. 155; Françoise Cachin describes the scene as “a solemn, quasi-sacerdotal ritual . . . a mysterious ceremony of initiation,” in *Seurat: Le reve de l’art-science* (Paris: Gallimard, 1991), p. 96; Robert Herbert proposes both “magician” and, arguing for Egyptian sources, an Osiris figure, with its hints of the underworld and sacrifice, in “‘Parade de cirque’ de Seurat et l’esthétique scientifique de Charles Henry,” p. 18. For a literary background to some of these iconographic possibilities, see E. M. Butler, *The Myth of the Magus* (Cambridge: Cambridge University Press, 1948). The figure of “le Mage,” as the authentic artist who creates “harmonie” out of “la vraie Science,” is associated with Leonardo, Beethoven, and Wagner in Teodor de Wyzewa, “Le pessimisme de Richard Wagner,” *Revue wagnerienne* 6 (July 8, 1885), pp. 167–170.



Seurat, Parade de cirque, detail.

own synthetic construction and its fleeting insubstantiality. In this sense the central figure stands as a paradoxical overlapping of Weber's opposition of charismatic and bureaucratic domination. It suggests the way in which the prophetic or oracular individual, and the "unstable" domination implied by it, becomes assimilated into the administered and rationalized order of a money economy. Weber in fact uses the phrase "the castration of charisma" to describe its inevitable decline and "routinization" within the rise of permanent institutional structures.¹¹⁸ In a more general way, the painting elides the effects of religion and spectacle in that both operate through processes of isolation and symbolization. The "priestly" status of the trombone player (within the hierarchical and pseudo-scenic structure of the work) implies a pathos and metaphysics of *distance*, while at the same time the essential separation between reality and appearance, on which a priestly order depended, is dismantled by the painting itself. Yet it is impossible to detach the unsettling effects of this sideshow from its liminal position—between the activation of a broken collective memory on one hand and the imposition of modern oblivion on the other.

"Routinization" is especially appropriate for this bleak image of a collective experience of music, making it difficult to believe that the notion of harmony here for Seurat was anything but ironic.¹¹⁹ He is presenting music as a socialized activity, indicating the superficial appearance of a collective reception, now drained of any socially redemptive or utopian possibilities, and the immediacy of an audience of privatized and isolated consumers. The four musicians at the left are like the degraded and mocking remnants of what once might have been the living Dionysian reality of the antique chorus. Their grim monotony is equally remote from an earlier nineteenth-century ideal of musical performer as a quasi-sexualized virtuoso. Now fragmented into individual producers, they labor dronelike within a larger ensemble, with the boredom of a third-rate military band.¹²⁰ According to Jacques

118. Max Weber, *Max Weber: Selections in Translation*, ed. W. G. Runciman, trans. E. Matthews (Cambridge: Cambridge University Press, 1978), pp. 247–248. For a discussion of Weber's account of charismatic domination, and his distinctions between magical, religious, and rational charisma, see Wolfgang Schluchter, *The Rise of Western Rationalism: Max Weber's Developmental History* (Berkeley: University of California Press, 1981), pp. 118–128.

119. See the discussion of painterly representations of musical performance in the nineteenth century in Richard Leppert, *The Sight of Sound: Music, Representation, and the History of the Body* (Berkeley: University of California Press, 1993). One of the problems Leppert pursues is how "vision focuses on the physicality of music making itself (the sight of the body's labor to produce sound). . . . Music, despite its phenomenological sonoric ethereality, is an embodied practice, like dance and theater" (pp. xx–xxi).

120. The modern era of the trombone begins around 1800, when it was rediscovered not only for use in the orchestra but more specifically for music associated with public ceremony and especially as a

Attali, the organization of music in Europe shifted significantly after 1850 as it became more aligned with the rationalizing imperatives of industrial production. “The musicians—who are anonymous and hierarchically ranked and, in general, salaried productive workers—execute an external algorithm, a ‘score’ [*partition*] which does what its name implies: it allocates their parts. Some among them have a certain degree of freedom, a certain number of escape routes from anonymity. But they are the image of programmed labor in our society. Each of them produces only a part of the whole having no value in itself.”¹²¹ Of course this idea of the isolated part drained of value or sense corresponds to the empty combinatorial logic of the displayed zeros, and also to the operation of Seurat’s chromatics in which the individual mark or unit of color has no intrinsic meaning.

But clearly the effects of the painting are inseparable from its historical sedimentation, that it preserves the resonance of scenic space even as it annihilates it, that it retains a suggestion of rite and collective participation even as it discloses their vacancy, that it evokes the harmonic relationships and premodern mysteries implicit in music and in geometrical forms even as they are collapsed into modern abstraction and the image of a fully administered world.¹²² In a larger sense, the painting suggests the ambivalent fate of the category of the sacred within industrial society: according to Georges Bataille, “it is in just such a society (or any society with a tendency to reduce itself to homogeneity) that the sacred elements generally acquire a subversive value . . . within an aggregate that is no longer founded on social bonding but on personal interest it tends, on the contrary, toward its destruction.”¹²³ Already in the 1870s Gustav Fechner had attempted to rationalize the aesthetic appeal of the golden section by demonstrating that its ratios were merely those statistically determined to appeal to a majority of spectators.¹²⁴ More immedi-

part of the fast-growing phenomenon of the military band, according to Anthony Baines, ed., *The Oxford Companion to Musical Instruments* (Oxford: Oxford University Press, 1992), pp. 342–345.

121. Jacques Attali, *Noise: The Political Economy of Music*, trans. Brian Massumi (Minneapolis: University of Minnesota Press, 1985), p. 66.

122. Several art historians and critics have attempted to demonstrate that the proportions of the golden section are embedded throughout *Parade*. See, for example, the well-known and now generally discredited diagram in Henri Dorra, “The Evolution of Seurat’s Style,” in Henri Dorra and John Rewald, *Seurat* (Paris: Les Beaux-Arts, 1959), pp. lxxxix–cvii.

123. Georges Bataille, “The Moral Meaning of Sociology,” in *The Absence of Myth*, trans. Michael Richardson (London: Verso, 1994), p. 108.

124. Gustav Fechner, *Vorschule der Aesthetik*, vol. 1 (Leipzig: Breitkopf und Hartel, 1876), pp. 184–202. For a withering assessment of Fechner’s text and a general attack on positivist models of “physiological” aesthetics, see Benedetto Croce, *Aesthetic* (1901), trans. Douglas Ainslie (London: Peter Owen, 1953), pp. 390–398.

ately relevant to Seurat were Charles Henry's claims that the proportions of the golden section had particular dynamogenic properties.¹²⁵ Yet if we can speak of Seurat's "Pythagoreanism" (an enduring art historical commonplace about this artist), it is a deeply ambivalent characterization. The particular figuration of measurement, quantities, and ratios in *Parade de cirque* diagrams a crisis of value, a crisis that corresponds to Nietzsche's contemporary diagnosis of a devaluation of life and the world. If Seurat did in fact remark in 1888 to Gustave Kahn that he sought to make a modern-day equivalent of Phidias's Panathenaic procession, it makes sense more in terms of negation and inversion, a bitter rebuttal of the kind of neo-antique work that Puvis de Chavannes and others had been doing. However, the question of Pythagoreanism is also a potentially rich avenue into a painting that is centrally linked to both music and mathematics.¹²⁶ Charles Henry was one of many in Seurat's circle who were preoccupied with the contemporary relevance and value of Pythagorean thought.¹²⁷ Certainly, one of Seurat's most provocative declarations about his own work (from the 1890 letter to Maurice Beaubourg) has unmistakable Pythagorean implications: "Art is Harmony. Harmony is the analogy between opposites."¹²⁸

125. Charles Henry, *Cercle chromatique, présentant tous les compléments et toutes les harmonies de couleurs* . . . (Paris: C. Verdin, 1888), p. 52.

126. A monumental source for these ideas in Seurat's time was Anthelme Edouard Chaignet, *Pythagore et la philosophie pythagoricienne*, 2 vols. (Paris: Didier, 1873). Seurat's friend Charles Henry frequently buttressed his own work with references to Pythagoras. See, for example, "Le contraste, le rythme, la mesure." Henry conceived of his lifework as the groundwork and preparation for "the renewal, in the near future, of Ontology, utilizing the immense progress of science, and for the instituting of Pythagoreanism and the Kabbala on scientific foundations," according to Francis Warrain, *L'oeuvre psychobiologique de Charles Henry* (Paris: Hermann, 1938), p. 491.

127. It's possible that Seurat and Henry were aware of at least superficial similarities between contemporary theories of dynamogeny and elements within Pythagorean tradition: "Even more immediately evident is the undeniable influence of Number on our psychic state through the medium of music, depending as it does on numerical proportion. Certain musical proportions express a sense of cheerfulness; others, such as the minor third, possess a bittersweet quality that can make us sad. The fact that number can influence a person's emotional state is indeed mysterious and points toward a dimension of qualitative Number which transcends the merely quantitative." K. S. Guthrie, *The Pythagorean Sourcebook*, ed. David Fideler (Grand Rapids, Mich.: Phanes Press, 1987), p. 34.

128. Seurat, letter to Beaubourg, in Broude, ed., *Seurat in Perspective*, p. 18. The key source for the Pythagorean doctrine of opposites was Aristotle's *Metaphysics*. See *The Complete Works of Aristotle*, vol. 2, ed. Jonathan Barnes (Princeton: Princeton University Press, 1984), pp. 1559–1562. Another text, widely referred to in the 1880s, was the account by the fourth-century A.D. Neoplatonic mystic Iamblichus. This work certainly suggested the notion of Pythagoreanism as a social project of reconciliation through the use of aesthetic form: "He thought that the training of people begins with the senses, when we see beautiful shapes and forms and hear beautiful rhythms and melodies. So the first stage of his system of education was music: songs and rhythms from which came healing of human temperments and passions." Iamblichus, *On the Pythagorean Life*, trans. Gillian Clark (Liverpool: Liverpool University Press, 1989), p. 26.

It might be possible to specify the painting's evocation of disenchantment, of the loss of transcendent signifiers, as part of a deliberate negation or degradation of Pythagorean values. *Harmonia* and number, which Aristotle identified as the constituents of the Pythagorean cosmos, and both central to Seurat's thought, are deployed in a world of mere empirical relations, cut off from the infinite (loss of the vanishing point) and from the light of either sun or moon (gaslight illuminates the scene).¹²⁹ If, in the Pythagorean tradition, music had healing powers and was an instrument for enhancing social cohesion, music in *Parade de cirque* seems at once anesthetic and an element of modern anomie.¹³⁰ At the same time, any speculation about Seurat's political leanings, about his "anarchism," could only be enriched by one of the key contemporary characterizations of Pythagorean social doctrine, what the Platonic tradition had referred to as "the peculiar mode of life" of the Pythagoreans. Quite simply, in the context of post-1871 France, this is an anxious euphemism for primitive communism, for various accounts that his followers all "held their goods in common."¹³¹

But most significant for this possible reading is the central trombone player and the precise location of the musical instrument. The lefthand tube of the trombone is the central vertical axis of the painting, that is, it mathematically bisects the rectangular image, and thus reverberates with the accumulated historical significance of this pictorial partitioning.¹³² At this pivotal site in the work, then, is a

129. Philosopher Charles Renouvier had insisted that the most relevant element of Pythagoreanism for modern thought was its opposition of "number" and "the infinite," and he asserted that "for the Pythagoreans, the infinite was the void [le neant] of knowledge," the limitless and undetermined against which number was both rational limit and determination. Renouvier, *Essais de critique generale. Premier essai* (Paris: Ladrangue, 1854), p. 381. But by conflating zero (which has no limiting or determinate function) with site of the vanishing point, Seurat operates outside the moral dualism at the foundation of this system.

130. It would be misleading simply to equate Pythagoreanism with premodern, mystical values when in fact some of the great "disenchancers" at the origins of modern Western science are deeply Pythagorean in their outlook. "Nevertheless, the major thesis of the Pythagoreans, namely, that nature should be interpreted in terms of number and number relations, that number is the essence of reality, dominates modern science. The Pythagorean thesis was revived and refined in the work of Copernicus, Kepler, Galileo, Newton and their successors, and is represented today by the thesis that nature must be studied quantitatively." Morris Kline, *Mathematics in Western Culture* (Oxford: Oxford University Press, 1953), p. 78. Michael Polanyi insists that Descartes's universal mathematics is a manifestation of Pythagoreanism: "his hope of establishing scientific theories by the apprehension of clear and distinct ideas, which as such were necessarily true." *Personal Knowledge* (Chicago: University of Chicago Press, 1958), p. 8.

131. Charles S. Peirce in 1892 insists on the "undeniable political character" of the original Pythagorean community and refers to Pythagoras as "one of the greatest names in the history of science" in his Lowell Lectures on the History of Science, in *Charles Sanders Peirce: Selected Writings*, ed. Philip P. Wiener (New York: Dover, 1958), pp. 239–246.

132. For an exemplary discussion of the theological deployment of a central vertical axis, see David Rosand, "Raphael and the Pictorial Generation of Meaning," *Source: Notes in the History of Art* 5, no. 1 (Fall 1985), pp. 38–43.

line that links the mouth of the figure with its crotch and which designates a device fundamentally dependent on breathing. In Pythagorean thought, breath was a primal cosmogonic principle: respiration with its binary rhythm of inhaling and exhaling was the original generative force, like the literal sexual act, the mutual interaction of contraries, the union of the limited and the unlimited. Thus this unsettling figure can bear a large but not unwarranted interpretive burden. Its location has a mathematically determined identity, making it a figure for the congruence of music, number, and harmony. In its literal operation the trombone stands for an overlapping of the cosmic procreative powers of numbers (as musical relations), breath, and sexual intercourse.¹³³ The question, though, remains: are these elements deployed parodically, ironically, or despairingly?

It is also important to note the uncertain gender of the trombone player: the strange mix and blurring of conventional male and female attributes, the ambiguous articulation of thighs, legs, and hips and the hauntingly nebulous features of its face, of sockets with no eyes.¹³⁴ Its imperious centrality seems strangely at odds with its attenuated, even spindly silhouette. The primordial Orphic intuition of the double but unified nature of human existence (which Pythagoreanism transformed into male and female numbers) is expressed here as a single sexually ambiguous figure.¹³⁵ The apparent androgyny of this figure is all the more striking given the highly legible and socially coded gender identity of almost every other individual in the painting. This disquieting object of fascination in the center of the painting at the lost vanishing point is evidence of the work's ambivalence: of both its destabilizing sexual confusion and its will to a reunification of what has been divided

133. On the problem of generation and procreation in Pythagorean thought, see Jonathan Barnes, *The Presocratic Philosophers*, vol. 2 (London: Routledge, 1979), pp. 76–81.

134. Sideshows, such as the one depicted in *Parade de cirque*, sometimes featured hermaphroditic performers. See Paul Smith, *Seurat and the Avant-Garde* (New Haven: Yale University Press, 1997), p. 191, n. 2, for reference to contemporary accounts of the *foires* that Seurat frequented, which describe the display of “des monstres qui sont a la fois homme, femme [of freaks who are both male and female].”

135. On the persistence of Pythagorean dualities in Western philosophy, see Michele LeDoeuff, “Women and Philosophy,” in Toril Moi, ed., *French Feminist Thought* (Oxford: Blackwell, 1987), p. 196. On the notion of an “original” bisexuality, see Judith Butler, *Gender Trouble: Feminism and the Subversion of Identity* (New York: Routledge, 1990), p. 54: “From the start, however, the binary restriction on sexuality shows clearly that culture in no way postdates the bisexuality that it purports to repress: It constitutes the matrix of intelligibility through which primary bisexuality becomes thinkable. The ‘bisexuality’ that is posited as a psychic foundation and is said to be repressed at a later date is a discursive production that claims to be prior to all discourse, effected through the compulsory and generative exclusionary practices of normative heterosexuality.” For a lucid insistence that the original “prototype” for the Pythagorean contraries was sexual difference, see F. M. Cornford, *From Religion to Philosophy: A Study in the Origins of Western Speculation* (1912; New York: Harper, 1957), pp. 65–72.

(color into complementaries, sex into gender, vision into figure/ground).¹³⁶ But as many writers have shown, androgyny is not an objective condition; it exists as a subjective projection onto socially constructed perceptual contents.¹³⁷ Seurat's "staging" of a historical crisis of value and representation coincides with another staging of a subjective sexual conflict. The historical archaism (through its multiple premodern allusions) of the trombone player is aligned with a parallel psychic regression in terms of a self-sufficient figure prior to separation and division, an historically sedimented figure that is also inseparable from the undifferentiated autoeroticism of early childhood (the trombone itself a concretization of overlapping phallic and oral impulses). Specifying the particular psychic material here (whether Oedipal or whatever) is probably less important than simply acknowledging the image as a phantasmic production, and providing some stronger terms for the endlessly repeated characterizations of *Parade de cirque* as dreamlike. Laplanche and Pontalis argue for a sharp distinction between fantasy and dream, that fantasy is always in part a secondary, waking elaboration of unconscious contents. Fantasy for them consists in "restoring a minimum of order and coherence to raw material handed over by the unconscious mechanism of displacement, condensation and symbolism, and in imposing on this heterogenous assortment a facade, a scenario, which give it relative coherence and continuity."¹³⁸ Relevant here for a reading of *Parade de cirque* is the idea of the facade, both as a gridlike ordering principle and as a screen concealing another unarticulable, imperceptible scene. At the same time it's possible to consider the screen itself as part of the fantasy. The operations of psychic condensation implicit in the trombone player, in

136. Jacqueline Rose's influential discussion of Freud and Leonardo is clearly relevant here: "The uncertain sexual identity muddles the plane of the image so that the spectator does not know where he or she stands in relationship to the picture. A confusion at the level of sexuality brings with it a disturbance of the visual field." Rose, *Sexuality in the Field of Vision* (London: Verso, 1986), p. 226. Richard Wagner, in discussing the androgynous significance of the title role in his *Parsifal*, referred to the figure of Christ at the center of Leonardo's *Last Supper*. Christ, he insisted, "must be entirely sexless. Leonardo, too, in the *Cena*, attempted that, depicting an almost feminine face adorned with a beard." Quoted in *Cosima Wagner's Diaries*, trans. Geoffrey Skelton (New York: Harcourt, Brace, 1977), vol. 2, pp. 498–499.

137. See, for example, Francette Pacteau, "The Impossible Referent: Representations of the Androgyne," in Victor Burgin and Cora Kaplan, eds., *Formations of Fantasy* (London: Methuen, 1986), pp. 62–84. See also the extended political and cultural survey in A. J. L. Busst, "The Image of the Androgyne in the Nineteenth Century," in Ian Fletcher, ed., *Romantic Mythologies* (London: Routledge, 1967), pp. 1–96.

138. Jean Laplanche and Jean-Bertrand Pontalis, "Fantasy and the Origins of Sexuality," *International Journal of Psychoanalysis* 49, part 1 (1968), pp. 1–18. See the assessment of recent French analyses of phantasmic constructions in Herman Rapaport, *Between the Sign and the Gaze* (Ithaca: Cornell University Press, 1994), pp. 17–90.

its multiple resonances of seduction, authority, or exhibitionism, establish another important stratum on which the image diagrams an anxious uncertainty, both social and individual, about mastery, attraction, and power.¹³⁹

Attention here is organized very differently from in Manet's *In the Conservatory*, where its simultaneous bindings and scatterings are determined by the equivocal positions and relations of the male and female couple. That dispersal and wandering of attention would have been incompatible with the perceptual logic of *Parade de cirque*. Its phantasmic qualities in large measure derive from this figuration of an undifferentiated being which in turn hierarchizes and immobilizes the entire composition. It is part of an attempt to recover a perception prior to any "divisionism." The imaginary rebinding of male and female characteristics is fully related to the quest for a luminosity of an irreducible integrity, for what Seurat called a "spectral purity," which would transcend the chromatic division and decomposition on which the work is founded.¹⁴⁰ As Victor Burgin and others have argued, fantasy operates through a stabilization or an "arrest" that domesticates the unruly movements of desire. It thus takes on hieratic and tableau-like forms, such as we see in *Parade de cirque*, which organize "the otherwise formless indeterminacies, dispersions, displacements of desire of the individual subject."¹⁴¹

What is involved here is more than the rigidity of a geometrical composition serving as a "striated" psychic constraint. Rather, we must begin to think through the interdependence of this phantasmatic figuration and Seurat's attraction to the binary scheme of dynamogeny/inhibition; to see the operation of a larger strategy

139. I believe that the *psychological effects* (though not the iconographical background) of Seurat's trombone player have important links with the figures Thomas Elsaesser identifies in silent cinema (and in Syberberg's films) as "the monstrous, uncanny redeemers, tyrants, scapegoats, sorcerer's apprentices—Dr. Caligari, Mabuse, Nosferatu, the Golem." Elsaesser associates them with the persistent romantic figure of the Double whose appearance is always greeted "with the shock of recognition followed by an equally violent disavowal of such dangerous self-knowledge. It keeps in suspension just what the relationship is between self-image and object-choice, once this becomes a question of political self-realization and manifest destiny. . . . They make visible the extent to which the ambiguous feelings of love and hate, binding the subject to his alter ego, are in fascism repressed, displaced and 'streamlined' into the cult of the charismatic leader, via what, after Freud, is 'secondary narcissism.'" Elsaesser, "Myth as the Phantasmagoria of History: Syberberg, Cinema, and Representation," *New German Critique* 24–25 (Fall–Winter 1981–1982), pp. 108–154.

140. In a June 1890 letter to Felix Fénéon, Seurat makes the declaration: "The purity of the spectral element being the keystone of my technique." Reprinted in Broude, ed., *Seurat in Perspective*, p. 16.

141. Victor Burgin, "Diderot, Barthes, Vertigo," in Burgin and Kaplan, eds., *Formations of Fantasy*, p. 98. Part of Burgin's discussion engages Roland Barthes's claim that the contents of a tableau "function in the name of a transcendence, that of the *figure*, which receives the full fetishistic load and becomes the sublime substitute of meaning." Barthes, *Image, Music, Text*, trans. Stephen Heath (New York: Hill and Wang, 1977), p. 72.

of immobilization and control. This means considering why this system is so intrinsic to *Parade de cirque*, even more so than the obviously “dynamogenic” demonstrations of *Chabut* and *Cirque*. It means understanding the importance to Seurat of a table of opposites, of dualities which, through his consummate adjustments, would at least point to the utopian possibilities of harmony. (And in the 1880s, Pythagoreanism was simply one historically exhausted name for such thinking). Seurat’s art must be evaluated less in terms of the particular “opposites” or “contraries” with which he worked (colors, lines, forces, sexes, numbers) than of the abstract functioning of such a binary logic and its relation to the formal idea of *reconciliation*, even if *Parade de cirque* simultaneously dissolves its own reconciling aspirations. Seurat’s Pythagoreanism is unavoidably complicit with the technocratic dream of a quantifiable harmony that a machinic world installs or restores.

Within the larger problem of Seurat’s disavowal of desire, what is in question is the attraction of a physiologically based theory of excitation that posed at least the possibility of a conceptual mastery of the inchoate pulsings of his own subjectivity. By intellectually grounding affect (or desire) in the mechanical economy of the nervous system, in a topographical distribution of energy, it offered a rationalization of otherwise unbearable desires that were in fact constructed elsewhere and were utterly irreducible to such a fraudulent dualistic scheme.¹⁴² Crucial in *Parade de cirque* is the congruence between the apparent reunion of opposites in the central figure and the specific formal deployment of the dynamogenic/inhibitory system. The insistent horizontals and the almost complete absence of diagonals, as well as the “neutral” chromatic organization, announce that in this work *neither* a dynamogenic (gay) nor an inhibitory (sad) effect is sought, but rather a *neutralization* of those poles. This is how the two zeros must also be read—as a quantitative expression of the affective operation of the system. Zero over zero, $\frac{0}{0}$: this stunning, stupefying quotient is finally the most powerful evocation of the inert “harmony” Seurat seeks. The nullification of the constructed categories of male and female, and the canceling out of two opposing modes of nervous energy, are parallel indications of “calmness,” the word Seurat used to designate the resolution of opposites. Calmness (or the Greek-derived *ataraxie*) is emphatically a

142. See Butler, *Gender Trouble*, p. 71: “The phantasmic nature of desire reveals the body not as its ground or cause, but as its *occasion* and its *object*. The strategy of desire is in part the transfiguration of the desiring body itself. Indeed, in order to desire at all it may be necessary to believe in an altered bodily ego which, within the gendered rules of the imaginary, might fit the requirements of a body capable of desire. This imaginary condition of desire always exceeds the physical body through or on which it works.”

reduction of tensions, a reduction even to a zero threshold, to what Freud called the “Nirvana principle,” or the cessation of all drives. The semantic and economic nihilism of these ciphers is adjacent to another perhaps more powerful operation of dissolution, which Freud so consequentially described: “The dominating tendency of mental life, and perhaps of nervous life in general, is the effort to reduce, to keep constant or to remove internal tension due to stimuli . . . and our recognition of that fact is one of our strongest reasons for believing in the existence of death instincts.”¹⁴³ To invoke this layer of fatality in *Parade de cirque* is certainly not to anchor the significance of the work in the abyssal resonances of Freud’s problematic concept, but rather to suggest the disturbing multivalence of the “homeostasis” that Seurat establishes.¹⁴⁴ The ideal of a diminution of tension, of a “constancy” of affect operates here both as a regression to a preindividuated unity and as the utopian projection into the future of a social harmony in which division and separation have been overcome, even if it is the quiescent harmony of a neopolis. The implicit effect of this “theater” of equilibrium is the erasure of both individual and historical temporality. It is a dream that begins, at least in its nineteenth-century guise, with Schopenhauer—the dream of an attention absolved of the play of difference, of flux—of a perception that becomes a suspension of will, a submission to the frozen phantasmic logic of unification. As Jean-Jacques Nattiez has concluded, it is a question of the illusion that “humanity could reach a stable point at which contradictions no longer exist and time can be arrested. . . . It is for this reason that androgyny and death so often appear together,

143. Sigmund Freud, *Beyond the Pleasure Principle*, trans. James Strachey (New York: Norton, 1961), pp. 49–50. See the remarkable critique of Freud’s text in Jean Laplanche, *Life and Death in Psychoanalysis* (Baltimore: Johns Hopkins University Press, 1976), pp. 103–124. Laplanche discusses the problematic nonidentity between a “zero principle” and a “constancy principle.” For Freud, he writes, “it is the whole of the biological domain, its history as well as its contemporary manifestations, which are infested by the immanence of a tendency to zero, working obscurely but ineluctably within” (p. 117). Some of Jean Baudrillard’s reflections from the mid-1970s are relevant to an analysis of this highly charged area of the painting: “In the capitalist mode, everyone is alone before the general equivalent. It is no coincidence that, in the same way, everyone finds themselves alone before death, since *death is general equivalence*. From this point on the obsession with death and the will to abolish death through accumulation become the fundamental motor of the rationality of political economy. Value, in particular time as value, is accumulated in the phantasm of death deferred, pending the term of a linear infinity of value.” Baudrillard, *Symbolic Exchange and Death* (1976), trans. Iain Hamilton Grant (London: Sage, 1993), p. 146; emphasis in original.

144. In her reevaluation of Freud’s *Beyond the Pleasure Principle*, Kaja Silverman provides a framework for understanding Seurat’s obsession with maintaining intellectual control over his work: “Masculinity is particularly vulnerable to the unbinding effects of the death drive because of its ideological alignment with mastery. The normative male ego is necessarily fortified against any knowledge of the void upon which it rests, and—as its insistence on an unimpaired bodily ‘envelope’ would suggest—fiercely protective of its coherence. . . . Disintegration constantly halts the subject’s attempts to effect a psychic synthesis.” Silverman, *Male Subjectivity at the Margins* (New York: Routledge, 1992), p. 61.

that social utopias end in massacres and that the structuralist utopia of an all-embracing explanation of mankind reducible to torrents of binary oppositions results in ‘nothingness.’”¹⁴⁵

But this projection of the neutralizing of drives in *Parade de cirque* hardly operates according to a seamless internal logic, any more than does the simulated *excitation* of response in *Cirque* and *Cbabut*. The central figure, the zero over zero equilibrium, the geometrical organization—all of these finally are neither static nor stabilized in *Parade de cirque*.¹⁴⁶ Just as was the case on its molecular level, there is no Gestalt capable of ordering the work. The androgynous significance of the central figure is bound up in a literally “crucial” feature of the painting: Seurat has carefully calculated his/her position to overlap with the hypothetical cruciform created by the horizontal and vertical bisection of the painting rectangle. If the shaft of the trombone coincides with the vertical midpoint, the related horizontal intersects it in the middle of the lower torso of the figure. This formal center of the painting coincides with where the phallic (though also double-sexed) trombone overlaps the anatomical position of the womb. In a more abstract sense, this highly charged site within the work is the symbolic representation of a matrix.¹⁴⁷

The idea of matrix here may seem remote from the generative cosmogony of a pre-Socratic imagination. The zeros adjacent to the figure hardly seem like signs of a mythical world egg but rather emblems of a sterility and impotence,

145. Jean-Jacques Nattiez, *Wagner Androgyne*, trans. Stewart Spencer (Princeton: Princeton University Press, 1993), p. 300.

146. Jacques Lacan insists on the “finiteness of desire” in terms of, or in spite of, the zero function: “Everyone knows that if the zero appears in the denominator, the value of the fraction no longer has meaning, but assumes by convention what mathematicians call an infinite value. In a way, this is one of the stages in the constitution of the subject. In so far as the primary signifier is non-sense, it becomes the bearer of the infinitization of the value of the subject, not open to all meanings, but abolishing them all, which is different. . . . What, in effect grounds, in the meaning and radical non-meaning of the subject, the function of freedom, is strictly speaking this signifier that kills all meanings.” Lacan, *Four Fundamental Concepts of Psycho-analysis*, p. 252. Kaja Silverman explains that for Lacan, the zero is the antithesis of a transcendental signifier. The nonmeaning of the zero “initiates the process of endless displacements and substitutions which comprise signification. . . . At the same time, it deprives the subject of any autonomy. As a consequence of the central part played by the unary signifier in the organization of the subject, the latter has no meaning of its ‘own,’ and is entirely subordinated to the field of social meaning and desire.” Silverman, *The Subject of Semiotics* (New York: Oxford University Press, 1983), pp. 172–173.

147. “The growth of the cosmos is described in the manner of the pre-Socratics, as the growth of a living being, and embryological concepts form a part of the background. The One begins to breathe and as the breath flows in, it assumes a more complicated structure.” Walter Burkert, *Lore and Science in Ancient Pythagoreanism*, trans. Edwin L. Minar (Cambridge: Harvard University Press, 1972), p. 37. See the discussion of the problem of procreation and the symbols of maternity and paternity in the political context of the French Third Republic in Julia Kristeva, *La révolution du langage poétique* (Paris: Seuil, 1974), pp. 441–508.

much like the barren tree at the left, at the core of this bleak and archaized cityscape, in a way that anticipates some themes of early twentieth-century modernism.¹⁴⁸ The slide trombone remains sexually charged but as an unproductive and mechanized autoeroticism. More importantly, however, the zeros are only the visible part of the admission price sign; when the unseen integers of the sign are considered as well, it makes up a square configuration of single numbers, with the two zeros constituting a right-hand column and the unseen numbers a left-hand column. This is a basic mathematical “matrix” (which first nominally entered modern computational practice in the 1850s), and as such stands for a quantitative conception of the entire structure of the painting. That is, a matrix is “a rectangular array of mathematical elements that can be combined to form sums and products with similar arrays having an appropriate number of rows and columns”—also “something resembling a mathematical matrix, esp. in rectangular arrangement.”¹⁴⁹ Even if all its constituent elements were zeros, it still would subsist as a functional matrix.¹⁵⁰ It’s possible, then, to see the matrix-like structure of *Parade de cirque* not simply as a grid (which modernist criticism has repeatedly suggested) but as a tabular field that is inseparable from its *enumerative* components with specifically generative possibilities. It becomes a modernized version of Durer’s magic square, but the creative capacities of that square have been remade into a purely functional significance in which the realm of the merely quantitative is never exceeded, in a modernized logic of capitalist accumulation. The matrix, then, is also what relocates Seurat’s system of drives out of both figuration and scenography into the

148. In support of Wagner, the youthful Nietzsche formulated what would be a standardized late romantic notion of a lost matrix, which is relevant to assessing Seurat’s own historical eclecticism: “And now the mythless man stands eternally hungry, surrounded by all past ages, and digs and grubs for roots, even if he has to dig for them among the remotest antiquities. The tremendous historical need of our unsatisfied modern culture, the assembling around one of countless other cultures, the consuming desire for knowledge—what does this all point to, if not to the loss of myth, the loss of the mythical home, the mythical maternal womb?” Nietzsche, *The Birth of Tragedy* (1872), trans. Walter Kaufmann (New York: Vintage, 1967), p. 136.

149. *Merriam-Webster’s Collegiate Dictionary*, 10th ed. (Springfield, Mass.: Merriam-Webster, 1993), p. 717. “The term ‘matrix’ was first assigned to a rectangular array of numbers by James Joseph Sylvestre in 1850. . . . But it was Arthur Cayley, in his paper ‘A memoir on the theory of matrices,’ in 1858, who first considered $m \times n$ matrices as single entities subject to certain laws of combination.” Howard Eves, *Elementary Matrix Theory* (New York: Dover, 1966), p. 10. See also Dirk J. Struik, *A Concise History of Mathematics*, 4th rev. ed. (New York: Dover, 1987), pp. 32–33. A matrix is described as “basically, a very simple way of organizing the numbers used to describe the various kinds of information that come to our attention every day,” in Paul Horst, *Matrix Algebra for Social Scientists* (New York: Holt, Rinehart and Winston, 1962), p. 5.

150. “A matrix in which all entries are zero is a *null matrix*, generally denoted by 0 or by the Greek letter θ (theta).” See Jan Gullberg, *Mathematics: From the Birth of Numbers* (New York: Norton, 1997), pp. 637–670.

formless, abstract flux of capitalist exchange. As both Rosalind Krauss and Jean-François Lyotard have shown, the concept of matrix, inflected by psychoanalytic discourse, designates not an intelligible organization of stable positions and values but rather processes beyond the threshold of visibility in which identities and meanings are converted into their opposites.¹⁵¹ Perhaps now it is clearer why the elimination of orthogonals is so decisive here; it establishes a powerfully modern ordering of desire and exchange in which any geometrical semblance of stability is a mask over a more powerful dispersal and circulation of affect. The “annulment” of difference figured in the columns of this matrix, rather than grounding our attention in a timeless, suspended presence, opens onto the vertigo of ceaseless differentiation. The congruence of signifier and the money-form discloses the perpetual deferral of desire, of immediacy, of presence. Perception becomes fatally caught up in the annihilating temporalities and substitutions of capitalist representation. It is, as Marx knew, a system in which appearance can only be thought as disappearance.¹⁵²

I have been attempting to indicate how the collapse of scenic space in *Parade de cirque* is inseparable both from a new organization of economic exchange and from a regressive fantasy of a primal immediacy. To achieve its aims, each of these requires an overcoming of a classical separation of subject and object, in which the two are defined in terms of stable and spatializable positions. One feature of the painting seems particularly significant in this regard: the tree at the left. I want to propose that, in addition to its obvious referential status, it could well indicate something else: a sign of a full commingling of eye and world, of an imaginary fusion of subject and object. To explore this possibility, however, requires a brief glance at scientific discourse on the eye in the mid-nineteenth century. As I have detailed elsewhere, a decisive shift occurs between 1810 and 1830 from the geometrical optics, based on the properties of light and its refraction and reflection, of the seventeenth and eighteenth centuries to a physiological optics, first outlined in the work of Goethe, Purkinje, Johannes Muller, and others.¹⁵³

151. See Rosalind E. Krauss, *The Optical Unconscious* (Cambridge: MIT Press, 1993), pp. 220–222; and Jean-François Lyotard, *Discours, figure* (Paris: Klincksieck, 1971), pp. 333–339.

152. Marx, *Grundrisse*, p. 209. See the discussion of how capitalism operates “by difference even before representation can arise,” thus producing “the dead time of difference as such,” in Gayatri Chakravorty Spivak, “Speculations on Reading Marx: After Reading Derrida,” in Derek Attridge, Geoff Bennington, and Robert Young, eds., *Post-Structuralism and the Question of History* (Cambridge: Cambridge University Press, 1987), p. 41.

153. See my *Techniques of the Observer*, pp. 67–96.

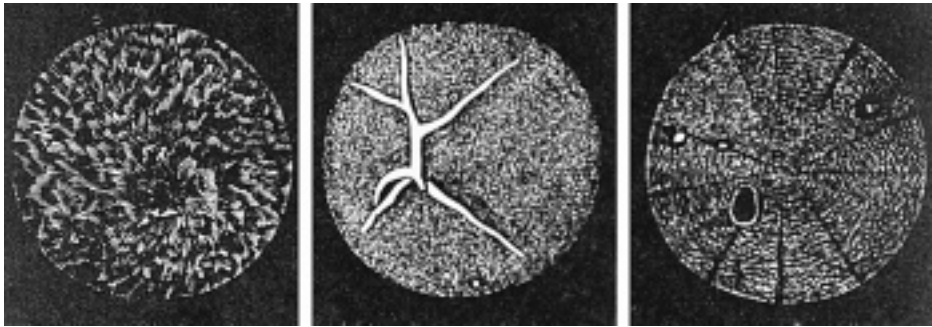

Entoptical phenomena, from Helmholtz's Physiological Optics.

The culmination of this shift was the publication between 1856 and 1866 of the three volumes of Hermann Helmholtz's *Treatise on Physiological Optics*, which not only presented Helmholtz's own extensive studies of human vision but also summarized the collective achievements of other researchers up to that time.¹⁵⁴ One of the effects of Helmholtz's widely read work was to undermine with finality any sense of the eye as a transparent organ and to put forth a comprehensive account of human vision in all its anatomical and functional complexity. The eye emerges in this text not only as a marvelous apparatus but as one with built-in aberrations, proneness to error, and inconsistencies in its processing of visual information. Helmholtz emphatically embeds the eye within the thickness and opacity of the body.

One of the ways in which Helmholtz overthrows the notion of the eye's transparency is his discussion of how under certain conditions objects *within* the eye itself become visible. These perceptions are what he and other researchers termed *entoptical* phenomena, of which he describes several categories. The most obvious type, noted incidentally by writers on vision for centuries, were the particles, specks, and other tiny aggregations suspended in the fluid medium of the vitreous humor of the eye, often called *mouches volantes*.¹⁵⁵ For William

154. The French translation of Helmholtz's work appeared in 1867 as *Optique physiologique*, trans. Emile Javal and N. Th. Klein (Paris: Victor Masson).

155. Arthur Rimbaud, in his "Les poètes de sept ans" (1871), describes such phenomena: "and he would see specks on his closed eyelids." Rimbaud, *Oeuvres complètes* (Paris: Gallimard, 1972), pp. 43–45. Another account of entoptical phenomena is in the work of the British scientist Sir Francis Galton: "When in perfect darkness, if the field of view be carefully watched, many persons will find a perpetual series of changes to be going on automatically and wastefully in it. I have much evidence of this. . . . Before I thought of carefully trying, I should have emphatically declared that my field of view in the dark was essentially of a uniform black, subject to an occasional light-purple cloudiness, and

James, entoptical phenomena are a key example of how selective attention excludes from consciousness sensations that are nonreferential, that are irrelevant to knowledge about the world. “The deepest inattention is to subjective optical sensations, strictly so called, or those which are not signs of outer objects at all.”¹⁵⁶ Helmholtz had articulated much the same pragmatic position: “We only attend with any ease and exactness to our sensations in so far as they can be utilized for the knowledge of outward things.”¹⁵⁷ To become aware of the subjective components of perception involved a conscious retraining of attention, in addition to specific techniques.

However, the most dramatic instance of an entoptical phenomenon is Helmholtz’s account of how an observer can see the blood vessels of his or her own retina. Researchers in the mid-nineteenth century discovered that the retinal blood veins were in a position to cast shadows on the rear surface of the retina, if certain luminous conditions were created. Helmholtz describes three methods of controlling the entrance of light into the eye that will render *visible to itself* its own retinal blood vessels. After detailing these instructions Helmholtz writes: “Now when the eye looks at a dark background, the latter will appear illuminated with a reddish yellow glow, and against this will be seen the dark retinal blood vessels ramifying in various directions like the branches of a tree. . . . As the focus of the lens is moved to and fro over the sclerotica, the branched figure accompanies the motion proceeding always ‘with’ the illumination. By such movements the vascular ‘tree’ is more clearly visible than with the light kept stationary on one spot.” This arborescent vocabulary was a pervasive feature of scientific and medical literature on the eye in the 1880s and remains so up to the present day.¹⁵⁸

other small variations. Now, however, after habituating myself to examine it with the same sort of strain that one tries to decipher a signpost in the dark, I have found that this is by no means the case, but that a kaleidoscopic change of patterns and forms is continually going on, but they are too fugitive and elaborate for me to draw with any approach to truth; I am astonished at their variety, and cannot guess in the remotest degree the cause of them; they disappear out of sight and memory the instant I begin to think about anything, and it is curious to me that they should be so certainly present and yet be so habitually overlooked.” Galton, *Inquiries into Human Faculty and Its Development* (London: Macmillan, 1883), pp. 158–159.

156. James, *Principles of Psychology*, vol. 2, p. 241.

157. Hermann von Helmholtz, *Treatise on Physiological Optics*, ed. James P. C. Southall (New York: Dover, 1962), pp. 431–432.

158. See, for example, a standard text, R. L. Gregory, *The Eye and Brain: The Psychology of Seeing*, 4th ed. (Princeton: Princeton University Press, 1990), p. 64, in which the blood vessels are described as a tree with many branches. Illustrations of the vascular “tree” appear three times in the 1867 French translation of Helmholtz’s work (*Optique physiologique*, pp. 31, 215, 254). Ernst Mach used the terms “sight phantasms,” borrowed from Johannes Muller, to describe entoptical phenomena, including the retinal blood vessels, and recounted: “On a number of successive days, a bright red capillary net (simi-

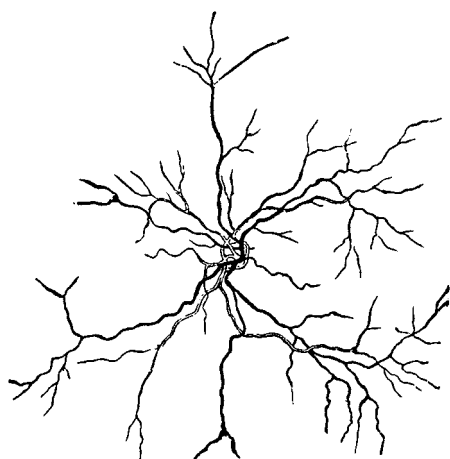

*Retinal blood vessels, or vascular “tree,”
from French edition of Helmholtz’s
Physiological Optics, 1867.*

Thus it might be possible to read an additional significance onto the tree at the left in *Parade de cirque*; that is, it could be both a tree and an allusion to the retinal tree as a sign of the body’s own inscription of itself onto a perceptual field, a binding of the physical eye to the structure of a visible world. Helmholtz’s book would have provided Seurat a map of a vision never detached from its own subjective corporeal conditions (and it would be difficult to reject the possibility of Seurat responding creatively to the most celebrated and influential book on vision available in 1887).¹⁵⁹ It allows another problematization of what the work “represents”: the eye’s self-perception of its own operation, the schematic contents of an objective world, or both. The study of physiological optics made clear that the photoreceptors in the human eye are placed at the back of the retina, behind the blood vessels; that is, the blood vessels literally intervene between the organ of seeing and what we see. It is another dramatization of the distinction between this new

lar to a so-called enchanted net), shone out upon the book in which I was reading, or on my writing paper. . . . When we withdraw the retina from outward excitations and turn the attention to the field of vision alone, traces of phantasms are almost always present.” Mach, *Contributions to the Analysis of the Sensations*, pp. 87–88.

159. By 1887, when Seurat planned and began *Parade de cirque*, this aspect of Helmholtz’s work had already penetrated mainstream cultural circles in France. See, for example, the discussion in Alfred Fouillee, “La sensation et la pensee selon le sensualisme et le platonisme contemporains,” *Revue des Deux Mondes* 82 (July 15, 1887), pp. 398–425: “Helmholtz has shown, in his *Physiological Optics*, how there are visual sensations which we do not perceive—blind spots, *mouches volantes*, afterimages, irradiations, chromatic fringes, marginal changes of color, double images, astigmatism, movements of accommodation and convergence, retinal antagonism, etc.” Also, the widely read work of Hippolyte Taine incorporated a wide range of Helmholtz’s observations. Taine’s claim that the apparent external world was in fact the play of “internal visual phantasms” referred directly to *Physiological Optics*. See Taine, *On Intelligence* (1869), trans. T. D. Haye (New York: Holt and Williams, 1872), pp. 285–337.

diagram of the eye and the model it displaced—the ideal, unobstructed functioning of the camera obscura. *Parade de cirque's* granular microstructure of divided color corresponds to the productive activity of the rods and cones within the retina, which Helmholtz indicated to be a highly dense “mosaic” of sensitive receptors, and the evocation of the vascular tree would be a figuration of the physical thickness of the eye that requires light to pass through a network of blood vessels and layers of nerve fiber in order to reach the optic nerve. *Parade de cirque*, I believe, has to be engaged as an inseparable mix of an abstract mathematically constructed space *and* a physiological perception more subjectively determined than anything Riegl might have been able to imagine. This plural surface of *Parade de cirque* is a fusion of opposites, an audacious attempt at overcoming the division of subject and object, at approximating that primordial (or infantine) dream of unification, of an unassailable immediacy.¹⁶⁰ We could thus read the tree's branches as “the veins through which the domain of vision has been integrated into the field of desire.”¹⁶¹ It is one more way in which *Parade de cirque* abandons a *scene* of representation and affirms phantasmic events that occur on the surface of bodies.¹⁶²

According to Jean-François Lyotard, it would be a mistake to attribute to the scenographic model of representation a distinct historical identity that has somehow been superseded. He maintains that the figure of the cube, the theater, the volumetric closure of representation has an enduring function within the economy of instinctual life. This cube or box can emerge anywhere, anytime, as a result of a particular (reactive) configuration of libidinal energy, or of a particular immobilization and objectification of the body. For Lyotard, the effective truth of the body is that it is a surface, what he calls a “band,” with a variable geometry, a Mobian skin

160. The dream of immediacy in Seurat's work is the fantasy of a theater without representation. In this sense the refusal of scenography, the nondisclosure of *Parade de cirque* also constitutes the imaginary conditions for the primordial event of festival. In Derrida's account of Rousseau's affirmation of political self-sovereignty, festival is “a stage which presents nothing to the sight. It is the place where the spectator, presenting himself as spectacle, will no longer be either seer or voyeur, will efface within himself the difference between the actor and the spectator, the represented and the representer, the object seen and the seeing subject. With that difference, an entire series of oppositions will deconstitute themselves one by one. . . . Presence will be full as the intimacy of a self-presence, as the consciousness or the sentiment of self-proximity, of self-sameness.” Derrida, *Of Grammatology*, trans. Gayatri Spivak (Chicago: University of Chicago Press, 1976), p. 306; emphasis added.

161. Lacan, *Four Fundamental Concepts of Psycho-analysis*, p. 85.

162. For Deleuze, the phantasm is an effect that “transcends inside and outside, since its topological property is to bring its internal and external sides into contact, in order for them to unfold onto a single side.” Deleuze, *The Logic of Sense*, trans. Constantin V. Boundas (New York: Columbia University Press, 1990), p. 211.

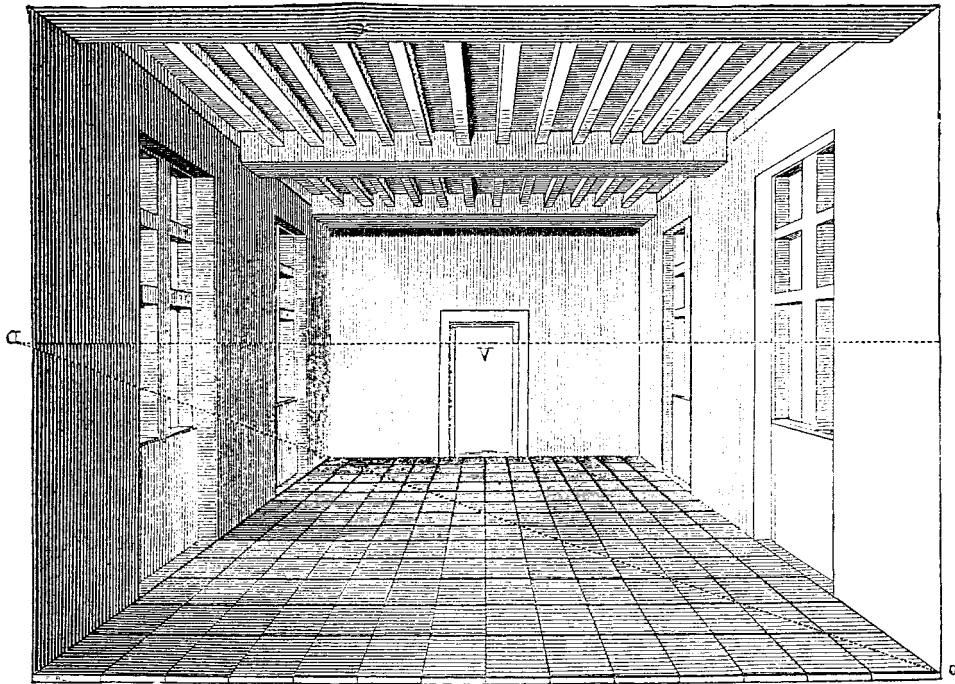

Perspectival cube, from 1880 edition of Charles Blanc, *Grammaire des arts du dessin*.

with no inside or outside, on which it is impossible to assume *a position*.¹⁶³ Yet it is this band or surface that is continually susceptible to being reshaped into a representational schema of presence and absence, interiority and exteriority.¹⁶⁴

163. Lyotard describes the band or the bar as “intensities running here and there, setting up, escaping, without ever being imprisoned in the volume of the stage/auditorium. Theatricality and representation, far from having to be taken as libidinal givens, *a fortiori* metaphysical, result from a certain labor on the labyrinthine and Moebian band, a labor which prints those particular folds and twists, the effect of which is a box closed upon itself, filtering impulses and allowing only those to appear on the stage which come from what will be known as the *exterior*, satisfying the conditions of interiority. The representative chamber is an energetic dispositif.” Jean-François Lyotard, *Libidinal Economy*, trans. Iain Hamilton Grant (Bloomington: Indiana University Press, 1993), p. 3. See also Lyotard’s discussion of “theatrical” space in *Des dispositifs pulsionnels* (Paris: Christian Bourgeois, 1973), pp. 95–102.

164. The Möbius strip, a nineteenth-century invention, is a crucial theoretical model for analyzing constructions of embodied subjectivity in Elizabeth Grosz, *Volatile Bodies: Toward a Corporeal Subjectivity* (Bloomington: Indiana University Press, 1994), p. xii: “The Möbius strip has the advantage of showing the inflection of mind into body and body into mind, the ways in which, through a kind of twisting or inversion, one side becomes another. This model also provides a way of problematizing and rethinking the relations between the inside and outside of the subject, its psychical interior and its corporeal exterior, by showing not their fundamental identity or reducibility but the torsion of one into the other, the passage, vector, or uncontrollable drift of the inside into the outside and the outside into the inside.”

Within Lyotard's particular revision of a Freudian schema, the inner theater takes shape as the result of excitations slowing down and becoming "bound," thus acquiring fixed positions and identities. The destruction of the trapezoidal semblance of the cube in *Parade de cirque* is inseparable from the postulation of the body as a surface, as a retina that is a heterogeneous field of sensitivities, as a nervous system circulating intensities and forces, reverberating through all different organs, a system with the possibility of states of relative equilibrium but more importantly a system in transition and oscillation. And for Seurat it is through the currents and surfaces of this body that there will be temporary coalescences of energy into images and phantasms, into the deceptive semblance of a theater of representation as in *Parade de cirque*.¹⁶⁵

But if it's possible to read *Parade de cirque* through Helmholtz's work, it is not merely that the painting outlines the effects or operation of a subjective vision, of a vision determined by the physiological limits of the body. It is more that the knowledge of a whole range of subjective conditions and limitations becomes part of a reorganization of the status of epistemological "objectivity." In the 1885 publication of Mach's *Analysis of the Sensations* an illustration depicts the author's visual field as seen through one eye, a field that includes his nose, moustache, eyelashes, and lower body. Just as one very rarely is aware of entoptical phenomenon, like retinal blood vessels, in ordinary visual experience one is seldom conscious of the ways in which the body is continually present but effectively deleted out of one's visual perceptions. Classical representation, from Alberti onward, defines itself by the fundamental subtraction of the body from the constitution of a visual field and by the related intellectual distinction between observer and object.¹⁶⁶ Mach was trying to highlight how certain visual habits correspond to particular philosophical prejudices, and in his enduring attacks on philosophical dualism he sought to overcome classical distinctions between "inner" and "outer"

165. For Lyotard, the theater of representation is always occupied by an exchangeable figure for what is exterior to that interior space: he calls it Zero. This is the sign that occupies "the empty center, the place where everything is supposed to be visible and intelligible, the place of knowledge." Zero becomes the figure for God, the organized body, society, capital, the ego, Platonic forms, and so on. See Lyotard, *Libidinal Economy*, pp. 1–16.

166. Erwin Panofsky discusses Renaissance perspective in terms of its effacement of the body. "For the structure of an infinite, unchanging and homogeneous space—in short, a purely mathematical space—is quite unlike the structure of psychophysiological space. . . . In a sense, perspective transforms psychophysiological space into mathematical space. It negates the differences between front and back, between left and right, between bodies and intervening space so that the sum of all the parts of space and all its contents are absorbed into a single 'quantum continuum.' It forgets that we see not with a single fixed eye but with two constantly moving eyes, resulting in a spheroid field of vision." Panofsky, *Perspective as Symbolic Form*, pp. 30–31.

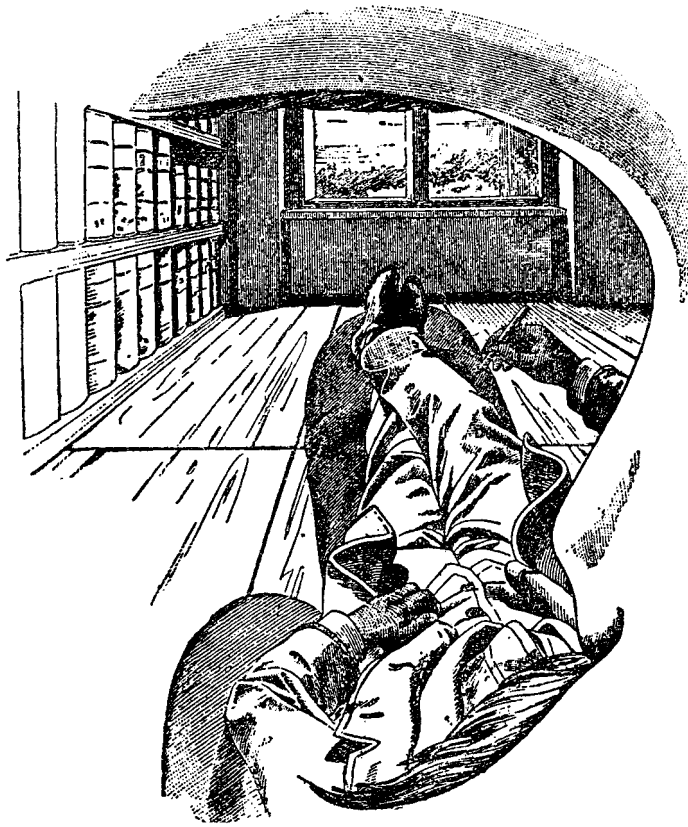

Ernst Mach, illustration from The Analysis of Sensations, 1885.

phenomena, between the physical and the psychic. The data of physiological experience were of crucial importance for him in demonstrating the interpenetration of these spheres. Though he shunned a monistic stance, any given phenomenon for Mach was an irreducible composite of properties belonging to the observer and features of the object observed, and certainly much the same could be asserted about Seurat's work after the mid-1880s: for both, the world was "one coherent mass of sensations."¹⁶⁷

167. Mach, *Contributions to the Analysis of the Sensations*, p. 23. "Mach's work constituted an effort to rescue the efficacy of science as a universal construct by retreating, so to speak, to the exclusive legitimacy of the act of perception. He generated a kind of legitimate, functional scientific impressionism." Leon Botstein, "Time and Memory: Concert Life, Science and Music in Brahms's Vienna," in Walter Frisch, ed., *Brahms and His World* (Princeton: Princeton University Press, 1990), p. 17.



How then to situate Seurat after the preceding speculations? It means rethinking my earlier remarks about the instrumentality of his method in relation to the “antiquarian” components of his project. Clearly Seurat must be considered as an artist deeply preoccupied with the modernization and rationalization of perceptual and aesthetic response, in the same way that this could be said of figures as diverse as, for example, Sergei Eisenstein, László Moholy-Nagy, and Arnold Schoenberg. One of the most suggestive summations of Seurat’s importance by an art historian is from the unlikely André Chastel, who associated him with the fictional composer Adrian Leverkühn in Thomas Mann’s novel *Doctor Faustus*, about the cultural crisis out of which National Socialism emerged. Seurat’s method, he writes, was “a research into archetypal forms (lines, colors, directions) which answered to a double and deliberately compounded ambition, at once archaic regression and scientific reduction. The painter’s operations set up a meeting point between an ancient hieratic art and the rationalized discipline of the future.”¹⁶⁸ This affiliation is important because it relocates the problem of Seurat into the midst of the most disturbing questions about modernity and rationalization. In hinting at a culturally reactionary component of Seurat’s project, it challenges those accounts that have dutifully and reductively identified his interest in science as inevitably allied with progressive political and social positions, as Meyer Schapiro began to do in the 1930s. Mann’s Leverkühn is far closer to the truth of Seurat in saying, “Most interesting phenomena probably always have this double face of past and future, probably are always progressive and regressive in one. They display the equivocalness of life itself,” as he defends his desire to fulfill the ancient aspiration of “resolving the magic essence of music into human reason.”¹⁶⁹ According to Chastel, in the domain of forms and colors Leverkühn’s ambition “bears the name Seurat.”¹⁷⁰ So it is not just that Seurat aligned himself with the scientific research of his own time

168. André Chastel, “Le ‘système’ de Seurat,” in *Seurat* (Paris: Flammarion, 1973), pp. 5–8. See the insistence that no notion of the modern “can in fact be constituted without reinventing its relation to the ancient. Indeed the modern consists wholly in such an invention,” in Philippe Lacoue-Labarthe, *Heidegger, Art and Politics*, trans. Chris Turner (Oxford: Blackwell, 1990), p. 58.

169. Thomas Mann, *Doctor Faustus*, trans. H. T. Lowe-Porter (New York: Knopf, 1948), p. 193.

170. Certainly Chastel is no Adorno, but his brief reflections that I’ve cited here contain more useful ideas with which to evaluate Seurat than some of the influential conclusions of Meyer Schapiro, to which I have already alluded. Who in fact is Schapiro’s Seurat? An enlightened, politically progressive artisan-artist embracing science and technological paradigms in the interests of forging an image of a nonhierarchical social world. Schapiro’s uncritical stance toward “science” and “technology” is obviously the product of a specific political and intellectual moment, but it is nonetheless regrettable that he approached “the rationality of method” in Seurat as a final locus of meaning rather than as the site of powerful and unresolved contradictions.

but that he sought confirmation anywhere (whether in the theories of Henry or those of Humbert de Superville, in the art of Egypt, Greece, or Delacroix) for the idea of a universal formula that would make rational and controllable the effects of color and form. In this sense, Ernst Bloch justifiably insisted on the “troublesome” ambivalence of Pythagoreanism: he understood that it was part of an animistic, premodern magical world view and yet deeply embedded in the essential assumption of modernity that all of nature is understandable in terms of number: “There is not even a sharp distinction between this mythical heritage and the new mathematical quantitative calculus” of modern thought.¹⁷¹ Similarly, all of Seurat’s late paintings, but especially *Parade de cirque*, must be seen in terms of his unresolvable problem—to think simultaneously the idea of universality in terms of aesthetic absolutes *and* the inescapable universality of modern exchange and circulation. It means stepping outside of an opposition between a social legacy of symbolic practices on one hand and the economic imperatives of high capitalism, and moving toward some of the proposals of Norman O. Brown and other historians. For Brown, “the money complex, archaic or modern, is inseparable from symbolism; and symbolism is not, as Simmel thought, the mark of rationality but the mark of the sacred. . . . At any rate, the historian must conclude that the ideal type of the modern economy retains, at its very heart, the structure of the archaic sacred. And once again the undialectical disjunction of sacred and secular is seen to be inadequate.”¹⁷² For too long, art historical work on Seurat consisted of empirical analyses in which his method was objectively interrogated and evaluated as either a success or failure. Much recent writing has engaged in pointless and often unreadable demonstrations that he “misunderstood” this or that scientific theory. Rarely articulated is the profound irrationality of his project, the excess, obsessiveness, sexual confusion, and paranoid secrecy that saturate the whole enterprise

171. The quotation is from a discussion of Kepler in Ernst Bloch, *The Utopian Function of Art and Literature*, trans. Jack Zipes and Frank Mecklenburg (Cambridge: MIT Press, 1988), pp. 60–61. Elsewhere Bloch’s assessment is somewhat different: “It was only in the modern era that the rift or schism began which, since Kepler at the latest, has opened between the *two sides of Pythagoreanism*. Between the quantitative side, on which metaphysics proper, which has been strictly scientific, developed, and the figural-qualitative, symbolic side on which so-called ‘holy mathematics’ was supposed to dwell. The latter had grown on a different social foundation than that which ultimately was interested solely in methods of calculation and the quality-less world corresponding to it.” Bloch, *The Principle of Hope*, vol. 3, p. 1350.

172. Norman O. Brown, *Life against Death: The Psychoanalytical Meaning of History* (Middletown, Conn.: Wesleyan University Press, 1959), pp. 247–248. For a different articulation of this problem, see John Brenkman, “Theses on Cultural Marxism,” *Social Text* 7 (Spring–Summer 1983), pp. 19–33: “Aesthetic experiences occur within, not above, the opposition of the symbolic and the economy, and within the lived conflict between self-activity and reification.”

and for which the surface of control, detachment, and logical rigor is merely a necessary mask.¹⁷³ (A rigid and unlikable person, he reminded Degas of a “notary,” while Emile Verhaeren compared him to a “silent reflective monk.”). What has put viewers off for over century, what is seen in his work as the graceless, mechanical assemblage of never quite integrated elements—this is not the result of an overly logical or merely misinformed application of theory. The unsettling (even if apparently bland) texture of the work derives from one thing above all else—an intuition of the loss of art’s immediacy; and Seurat’s relentless efforts to construct substitutes for that lost presence result from a parallel intuition of the shift of what might have been contemplation into mere attentiveness. We can certainly identify the instrumental character of Seurat’s art, but at the same time it cannot be understood in terms of some easy model of ascendant technocratic imperatives in the late nineteenth century. Seurat stands for that tragic subsumption of ends within the demands of a technical system whose rational extension becomes perpetually self-justifying. Thus attention in Seurat is finally attuned only to its immanence within that operation or imposition of system, even as it masks itself in luminous or spectacular surfaces, even as attention might be indistinguishable from the fluctuating tensions and relaxations of the body.

To put it another way, Seurat’s work concretizes the modern dilemma of the disappearance of aura more acutely than any other art practice. It can be reason-

173. The delirious psychobiography of Seurat has yet to be written; but the paucity of documentary traces of his relation to his extraordinary father will probably never allow him to emerge as a modernist “case” to rival Kafka’s or others. Antoine-Chrysostome Seurat was a figure in whom the psychotic borderlines of bourgeois male social identity in the nineteenth century were approached if not actually crossed. To designate the father’s condition simply as an “extreme obsessive-compulsive disorder” does not adequately address the overlapping of juridical, familial, and religious derangement in the conduct of his life. He was a court functionary (the bailiff and a notary in the La Villette district of Paris), a husband and father who lived separately and only returned home every Tuesday, with absolute regularity, to perform his conjugal duties, and a religious fanatic who decorated the walls of his home floor to ceiling with popular prints of Jesus, the Virgin, and saints and who, to the dismay of local church authorities, styled himself a “priest,” performing mass in his wine cellar for local peasants with the help of his gardener. In the face of this formidable paternal “desiring machine,” various reports reiterate the same predictable refrain: that Seurat was doted on by his mother, and that his own investment in the maternal bond was considerable. To add to the interpretive plenitude, Seurat’s father had lost part of his arm as a young man and been fitted with a mechanical prosthetic device, which, ominously, as Mary Gedo relates, he could use so dextrously “that he could neatly carve and distribute a roast, slice by slice, impaled on his hook.” The phantasmic impact of this artificial hand could be part of an extended reading of Seurat’s own development of a “mechanized,” repetitive touch (not to mention the “prosthetic” quality of the metallic trombone in *Parade de cirque*). For some of the few attempts to work interpretatively with these elements of Seurat’s life, see Gedo, “The *Grande Jatte* as the Icon of New Religion”; and S. Hollis Clayson, “The Family and the Father: The *Grande Jatte* and Its Absences,” *Art Institute of Chicago Museum Studies* 14, no. 2 (1989), pp. 133–154. For biographical information, see the relevant sections in Henri Perruchot, *La vie de Seurat* (Paris: Hachette, 1966).

ably claimed that his paintings are the first attempt to rationally produce aura, and his “theories” an attempt to concoct its formula.¹⁷⁴ His immersion in the mechanics of vision was directed to the creation of a luminosity with no direct material substrate, of a chromatic unfolding existing apart from the mere objectivity of the work, that “appears” only in a subjective, even “interpersonal” relation to it. But even to attempt the creation of this luminous effect means bringing into the work the forms of rationalization that eradicated aura in the first place.¹⁷⁵ It is then no accident that his last major paintings are experiments in simulating different artificial forms of illumination, and that he situates both artist and spectator in a world bereft of “natural” white light, where the opposition of day and night is dissolved. The gas lighting across the top of *Parade de cirque* (to which its whole chromatic organization in principle refers) is itself a symbolic conjoining of all its luminous effects into larger networks of quantification and circulation, even as it simulates an acanthus motif from antique architecture.¹⁷⁶ The horizontal tubing connecting the lamps is a literalization of a line out of the nocturnal field of the image into the economic flows of urban space, leading finally to the huge squat gasometers on the outskirts of Paris, which Seurat well knew and which Paul Signac had painted a few years before.

Parade de cirque itself is a field of different kinds of artificial light: the gas lamps, the apparent aura or halo around the figures, and the photochemical

174. I use the word *aura* overlapping its literal meaning of “luminous radiation” with the associations loaded onto it in the work of Walter Benjamin. In *Parade de cirque*, the original sense of aura as “nimbus” is directly relevant to Seurat’s creation of glowing fields of light around his human figures.

175. This reversal, in which appearance is privileged over essence and technological rationality is deployed in the service of appearance, is, as we will see, one of the possible ways to associate Seurat with Richard Wagner. See the relevant discussion of Walter Benjamin’s notion of the “dialectical image” in Georges Didi-Huberman, “The Supposition of the Aura: The Now, the Then, and Modernity,” in Richard Francis, ed., *Negotiating Rapture* (Chicago: Museum of Contemporary Art, 1996), pp. 48–63. To produce a dialectic image “is to criticize modernity (the forgetting of the aura) through an act of memory and, at the same time, to criticize archaism (nostalgia for the aura) through an act of essentially *modern* invention, substitution and designification. Benjamin dismissed with the same gesture myth and technology, dreaming and waking, Carl Jung and Karl Marx” (p. 53).

176. As many have indicated, gas lighting in 1888 was somewhat outmoded in relation to new forms of electric arc lighting, which began to illuminate urban spaces by the early 1880s. But Wolfgang Schivelbusch has demonstrated that, even in 1890, the experience of nocturnal urban space was a patchwork of major central areas lit by incandescent light and a far more extensive area of secondary streets and spaces still lit by gas. Schivelbusch shows how a pedestrian experienced abrupt and disorienting optical shifts due to adjacent but radically different luminous environments: “The arc-light was, in fact, a small sun and the light it cast had a spectrum similar to that of daylight. In arc-light, the eye saw as it did during the day, that is with the retinal cones, while in gaslight, it saw as it did at night, with retinal rods. Stepping from an arc-lit into a gas-lit street fully activated the eyes’ mechanism for adapting to the dark.” Schivelbusch, *Disenchanting Light: The Industrialization of Light in the Nineteenth Century*, trans. Angela Davies (Berkeley: University of California Press, 1988), p. 118.

interaction of Seurat's pigments. It has been claimed many times, of course, that Seurat's divisionist technique resembles this or that technological innovation, from three-color printing processes in the 1880s to the mosaic of photoelectric cells in color television.¹⁷⁷ Regardless of the value of any such individual comparison, it is important to see that his experiments in search of a chromatically charged screen are part of a larger development described by Paul Virilio as the loss of direct vision, "the disintegration of a faith in perception," the reconfiguration of optical experience into synthetic and machinic operations that occur external to the observing subject.¹⁷⁸ One of the paradoxes of his decomposition of color is that it retains something of the attraction of an alchemical process. Seurat has to be understood outside of the now pervasive and misleading polarity between a romantic Goethean tradition of expressionistic color theory (northern and eastern European) and a modernizing quantitative color theory deriving from Chevreul, supposedly dominant in France. To characterize Seurat as representative of the latter is to miss how the methodical program of his technique is an attempt to conceal the parallel (even if hopeless) ambition of an alchemical transubstantiation, of overcoming the opacity and materiality of pigment to attain that archaic goal of, in Toulmin and Goodfield's phrase, "the redemption of matter."¹⁷⁹ One of the central questions about Seurat's work is the extent to which forms of synthesis (optical mixture) produce *qualitative* change. The purely additive and accumulative functions of industrialized procedures, which insinuate the most basic forms of modern social reproduction into the work, are haunted by the survival of what Bloch calls "a pre-bourgeois, non-quantitative connection to nature," for which color did not exist as an autonomous experience or as a separate and specialized science.¹⁸⁰ It must be recognized how Seurat's equivocal quest for an axiomatic of aura, and his

177. See, for example, Norma Broude, "New Light on Seurat's Dot: Its Relation to Photomechanical Color Printing in France in the 1880s," *Art Bulletin* 56 (December 1974), pp. 581–589, or Marshall McLuhan, *Understanding Media: The Extensions of Man* (New York: McGraw-Hill, 1965), p. 190.

178. Paul Virilio, *The Vision Machine*, trans. Julie Rose (Bloomington: Indiana University Press, 1994), p. 16.

179. Stephen Toulmin and June Goodfield, *The Architecture of Matter* (Chicago: University of Chicago Press, 1962), pp. 109–136. See the account of how premodern notions of transubstantiation remained influential in the nineteenth century and overlapped with the terms of both philosophical and scientific materialism, as well as thermodynamics, in Michel Serres, *Feux et signaux de brume: Zola* (Paris: Grasset, 1975), pp. 237–244.

180. Bloch, *The Utopian Function of Art and Literature*, p. 63. The complicated problem of Seurat's additive and "repetitive" technique (and its latent resistance to modernity) is suggested by Adorno: "It is impossible to consider the emphatic aesthetic idea of the new apart from the industrial procedures that increasingly dominate the material production of society. . . . Industrial techniques, however, the repetition of identical rhythms and the repetitive manufacture of an identical object based on a pattern,

desire for a luminous surface of fascination, are in fact the consequences of a colossal *disappointment* at the impossibility of immediacy and the historical inaccessibility of the dream of a ritual/magical practice of art. The work's exhaustive denial of presence incites the pursuit of another kind of immediacy: the fusing of eye and image as an attempt to overcome the absence figured in the work. Of course we can still situate Seurat within a familiar field of painters and their related aims and problems, as a member of what Paul Valéry called "the cult of light," but more importantly his work migrates toward a location outside some long-held assumptions about the arts, toward an abandonment of the idea that art is a medium for disclosing essential truths. There is also, in *Parade de cirque*, though I say this more conditionally, an abandonment of a redemptive optimism about art: it is a work in which the Apollinian veil, which Seurat sustained so tautly in some other works, is pitilessly pulled aside to reveal a void, glittering but menacing, behind it.



I want now to align my discussion of *Parade de cirque* more closely with some of the ways in which attention and perceptual response were being remade in institutional and social spaces. To do this, I return to the endlessly plural trombone player and its ambivalent construction. Having suggested its position within a desiring system dependent on operations of rebinding and immobilization, I want to examine the dissonance of this figure in terms of Seurat's language of unresolved opposites, and more specifically through his enduring preoccupation with the problem of *contrapposto*. His conceptual approach to the representation of the body, which developed in relation to this formal principle, was formed in the late 1870s both through his studies of antique works, studio models, and copies from Ingres and through his reading of various aesthetic and scientific treatises. As David Summers has shown, the Renaissance ideal of *contrapposto* invoked a metaphysical dualism that found expression in rhetorical devices of contrast and antithesis. Both the familiar notion of sculptural *contrapposto* and *chiaroscuro* (contrast of colors) were subsumed within the larger ideal of *opposition*. According to Summers, "*Contrapposto* could be decorative or structural. . . . Its final justification lay in its vividness, the clarity with which art by direct contrast could make opposites evident, or bring them into harmony. On this level antithesis touched

at the same time contain a principle antithetical to the new. This exerts itself as a force in the antinomy of the aesthetically new." Theodor W. Adorno, *Aesthetic Theory*, trans. Robert Hullot-Kentor (Minneapolis: University of Minnesota Press, 1997), p. 272.



Georges Seurat, Praxitelean Figure, early 1880s.

on basic principles and there was a continuous relation between nature, or our knowledge of nature, and art.”¹⁸¹ But just as Seurat demolished the structural conditions of classical scenography yet maintained a suggestion of its effects, he self-consciously negates the possibilities of classical contrapposto even as he presents the central figure in terms of a principle of “contrast”; for its discordant formation is remote from any notion of a harmonious continuity between nature and art.

The contrast set up in the trombone player elicits two seemingly incompatible modes of perceptual response. The top half of the figure, which clearly tends to dominate one’s apprehension of the work, is defined by the frontal and hieratic timelessness of archaic art.¹⁸² As such it presupposes a rapt, frozen attentiveness,

181. David Summers, “Contrapposto: Style and Meaning in Renaissance Art,” *Art Bulletin* 59 (September 1977). p. 357.

182. For an extended consideration of the formal characteristics of archaic or “primitive” Greek art, see Emanuel Loewy, *The Rendering of Nature in Early Greek Art*, trans. John Fothergill (London: Duckworth, 1907), pp. 5–75. For Humbert de Superville, the vertical axis of the human body had an originary and transcendent significance, in that an upright man was “turned toward heaven.” But he also identi-

caught up in the magical attraction of this object.¹⁸³ Yet the lower half of the body, in its willful yet almost careless deviation from a symmetrical relation to the central axis, in its casual shifting of the hips and distribution of weight onto the left leg, would seem to be an “awakening” out of the “archaic spell,” implanting the figure in the dynamic temporalities of autonomous movement. This at least was how contrapposto in classical art often came to be understood, as suggesting “a living organism controlled by an indwelling will, a person capable of acting spontaneously.”¹⁸⁴ But Seurat decisively repudiates that classical image of the body as an expression of a self-determining balance of internal forces. Instead, the lower half of the body seems severed from a sense of any unified autonomous will, and the legs seem as if swept by some external agency so far to the left of the vertical axis of the figure that there is no effective support for the impassive upper body. The lower legs, like wooden pegs, seem almost unanchored, as if the figure was a skillfully managed marionette, only tenuously abutting the ground.¹⁸⁵ In a more general sense, these limbs seem like parts of a mechanical apparatus rather than integrated components of human movement. Meyer Schapiro intuited something that remains essential for our understanding of Seurat when he pointed to his proximity to a range of modernizing technological practices, in particular to what Schapiro called “a taste for increasingly schematic movement.”¹⁸⁶ I would suggest that this could be specified further as movement both mechanical and automatic, which finally brings me back to the question of the *dissonance* of this figure. Rather than an incongruous composite of the frontality of archaic art and the harmonious oppositions of classical art, the figure suggestively elides the regressive immobility of trance with the machinic uncanniness of automatic behavior.¹⁸⁷

fied in the frontal verticality of archaic art “an innate and primitive expression of death.” See the opening paragraphs of his “Essay on the Unconditional Signs in Art” (1827), in *Miscellanea Humbert de Superville*, ed. Jacob Bolten (Leiden, 1997), p. 68.

183. Obviously the association of motionlessness with frontal, hieratic images is a qualified one. For example, in a discussion of twelfth-century icons, Hans Belting insists that “authentic images seemed capable of action, seemed to possess *dynamis*, or supernatural power. God and the saints also took up their abode in them, as was expected and spoke through them.” Belting, *Likeness and Presence: A History of the Image before the Era of Art*, trans. Edmund Jephcott (Chicago: University of Chicago Press, 1994), p. 6.

184. Denys Hayes, *Greek Art and the Idea of Freedom* (London: Thames and Hudson, 1981), p. 33.

185. During the late 1880s, there were several popular venues in Paris offering “theatrical” performances of marionettes, such as the “Maquettes animees” at the Alcazar d’Hiver theater where marionettes, three feet in height and made out of rubber, appeared as clowns, circus performers, and musicians. Jules Cheret designed a poster for this particular show.

186. Meyer Schapiro, *Modern Art, 19th and 20th Centuries: Selected Papers* (New York: Braziller, 1978), pp. 101–110.

187. Part of the dilemma presented by a more complete range of Leonardo’s notebooks in the late 1880s was how to reconcile his insights into “natural” movements and rhythms of living beings with

Seurat's late work is an exploration of subjective vision and its epistemological consequences, but also coincides with an understanding of perception and attention as inextricable parts of a social field of collective response. His representations of the crowd (or the crowd as a figure for the social) occur in a short-lived historical moment when hypotheses and statements about hypnosis, suggestibility, and automatic behavior (in terms of both individual and collective subjects) were not only permissible but widespread.¹⁸⁸ As I indicated earlier, the volatility of hypnosis as a cultural and scientific object was due to its dual status as a potential technique of control and a set of enigmatic phenomena that resisted intellectual mastery and dualistic conceptualizations. To historicize this ambivalent duality more fully, it is important to recall that the apogee of hypnosis as an object of institutional preoccupation may well have been in 1889, with the symbolic event of the First International Congress on Hypnotism held August 8–12 of that year in Paris.¹⁸⁹ It thus coincided with the great Universal Exposition of the same year, which is significant for several reasons. First, it aligned the public gathering of researchers on hypnosis (from all over Europe and North America) with the rationalizing ideological imperatives of the young Third Republic, imperatives that were concretized in the actual organization and layout of the Exposition and that had

his invention of diverse forms of repetitive mechanical motion. The impact of Leonardo's machinic studies in the late nineteenth century are discussed in Georges Canguilhem, "Machine and Organism," in Jonathan Crary and Sanford Kwinter, eds., *Incorporations* (New York: Zone Books, 1992), pp. 44–69. See the discussion of Leonardo in relation to the ambiguous history of automatons—of his production, on one hand, of the premodern machinery of court festivals and theater, and his conceptualization, on the other, of regularized proto-industrial forms of machinic processes—in Jean-Claude Beauce, *L'automate et ses mobiles* (Paris: Flammarion, 1980), pp. 76–88.

188. By the late 1880s, a huge amount of research and reflection on the problem of automatic behavior had been produced. Within psychology a key text was, as we have seen, Janet's *L'automatisme psychologique* (1889), in which he demonstrated the automatic components of perception, memory, and attention. Various philosophical debates still made reference to the "automata hypothesis" of Thomas Huxley, according to which consciousness was a mere epi-phenomenon, a superfluous addition to the operation of physiological processes. See Thomas H. Huxley, *Collected Essays*, vol. 1 (New York: D. Appleton, 1917), pp. 199–250. See, for example, the use of Huxley's hypothesis in relation to the study of automatisms in Alfred Binet, *On Double Consciousness* (Chicago: Open Court, 1890), p. 20. The larger historical resonances of this problem are implicit in Charcot's insistence that "the movements which exteriorly represent the acts of unconscious cerebration are distinguished by their automatic and purely mechanical character. Then it is truly that we see before us the *human machine* of De La Mettrie." Charcot, *Clinical Lectures on Diseases of the Nervous System*, p. 290.

189. On the proceedings at the Congress, and the open battle between the Nancy and Salpêtrière schools, see François Duyckaerts, "1889: Un congrès houleux sur l'hypnotisme," *Archives de Psychologie* 57 (1989), pp. 53–68. The exchange of ideas at the Congress is also discussed in Leon Chertok, "On the Discovery of the Cathartic Method," *International Journal of Psycho-analysis* 42, no. 3 (1961), pp. 284–287. Chertok emphasizes the almost simultaneous meeting in Paris of the first International Congress of Psychology (August 6–10, 1889), which had an important section devoted to hypnotism, and that many participants moved back and forth between the two events.

their “roots in the Enlightenment faith in man’s limitless potential for mastery of his environment.”¹⁹⁰ The Congress on hypnosis clearly paralleled these same objectives: hypnosis, for most of the participants, was optimistically seen as the most effective entryway into previously inaccessible territories and processes of human psychic life, and as a means of exploring, studying, and hopefully mastering this terrain, with the goal of new solutions and cures to both the mental and physical ills of human beings. Secondly, the Exposition of 1889 was unprecedented for its extensive presentation of colonial peoples and lifestyles as object of spectacle. Simulated “villages” inhabited by Congolese, Javanese, New Caledonians, Senegalese, and others became contents of an imaginary imperial space, contents that were supposedly assimilable into the rationalizing “taxonomy” of the exposition’s organizational schema.¹⁹¹

These events in the summer of 1889 were emblematic of a historical moment when both hypnosis and the material life of colonial peoples took on a public, and more specifically an *exhibitionary* existence at the threshold of their marginalization, assimilation, or disappearance. Obviously these are two very different historical objects, but both hypnosis (with its profoundly indecipherable trance states) and primitive cultures (with their singular forms of exchange, of value and power relations) were radically irreconcilable with dominant forms of Western rationalism. What was unassimilable in both was at least temporarily refigured as the survival (or simulation) of an earlier stage of development, as a lower, regressive, or childlike state of mind or culture. Hypnosis, as researchers disturbingly realized throughout the 1890s, placed familiar notions of individual identity in jeopardy. “Suggestion and hypnosis have always designated for Western rationality its own particular antithesis: influence without any logical foundation, and the production of an illusory relation with the world. . . . In other cultures, this is hardly the case; states of trance whether individual or collective are conceived as an opening up and a sharing.”¹⁹²

190. Deborah Silverman, “The 1889 Exhibition: The Crisis of Bourgeois Individualism,” *Oppositions* 8 (Spring 1977), pp. 71–91.

191. On the relation between the rise of anthropology as a discipline in the 1870s and the 1889 Exposition, see the discussion in Paul Greenhalgh, *Ephemeral Vistas: The Expositions Universelles, Great Expositions and World’s Fairs, 1851–1939* (Manchester: Manchester University Press, 1988), pp. 84–90. On the exposition’s “taxonomic” organization, see Silverman, “The 1889 Exhibition,” pp. 78–80.

192. Leon Chertok and Isabelle Stengers, *L’hypnose: blessure narcissique* (Paris: Les Empecheurs de penser en rond, 1990), p. 55. See the remarkable discussion of trance in various non-Western and premodern societies, where “trance constitutes a cultural model integrated into certain general representations of the world,” rather than simply a modality of individual experience, in Gilbert Rouget, *Music and Trance: A Theory of the Relation between Music and Possession*, trans. Brunhilde Biebuyck



Colonial village exhibition at Exposition Universelle, Paris, 1889.

In short, hypnosis, like the colonial villages at the 1889 Exposition, had its own *spectacular* identity. Well before Charcot's "performances" at the Salpêtrière in the 1880s, hypnosis had existed throughout much of the nineteenth century as a pervasive form of popular entertainment.¹⁹³ Frequently it would be the centerpiece of the quasi-scientific lecture or demonstration, a specifically nineteenth-century form of didactic entertainment. Just as often, however, the performance of a "magnetiseur" was itself a form of spectacle within a milieu of magic shows, of

(Chicago: University of Chicago Press, 1985). See also Paul Stoller, "Son et transe chez les Songhay du Niger," in Daniel Bougnoux, ed., *La suggestion: Hypnose, influence, transe* (Cerisy: Les Empêcheurs de penser en rond, 1991), pp. 145–161.

193. One of the most famous "magnetiseurs" was Charles Lafontaine, whose traveling show appeared across Europe between 1840 and 1852. Accompanied by music, subjects rendered insensible were pierced with hatpins and young working-class women were "ecstatically transfigured" into St. Theresa. See his *Memoires d'un magnetiseur* (Paris: Balliere, 1866). See also the discussion in Jacqueline Carroy, *Hypnose, suggestion et psychologie: L'invention de sujets* (Paris: Presses universitaires de France, 1991), pp. 89–96.

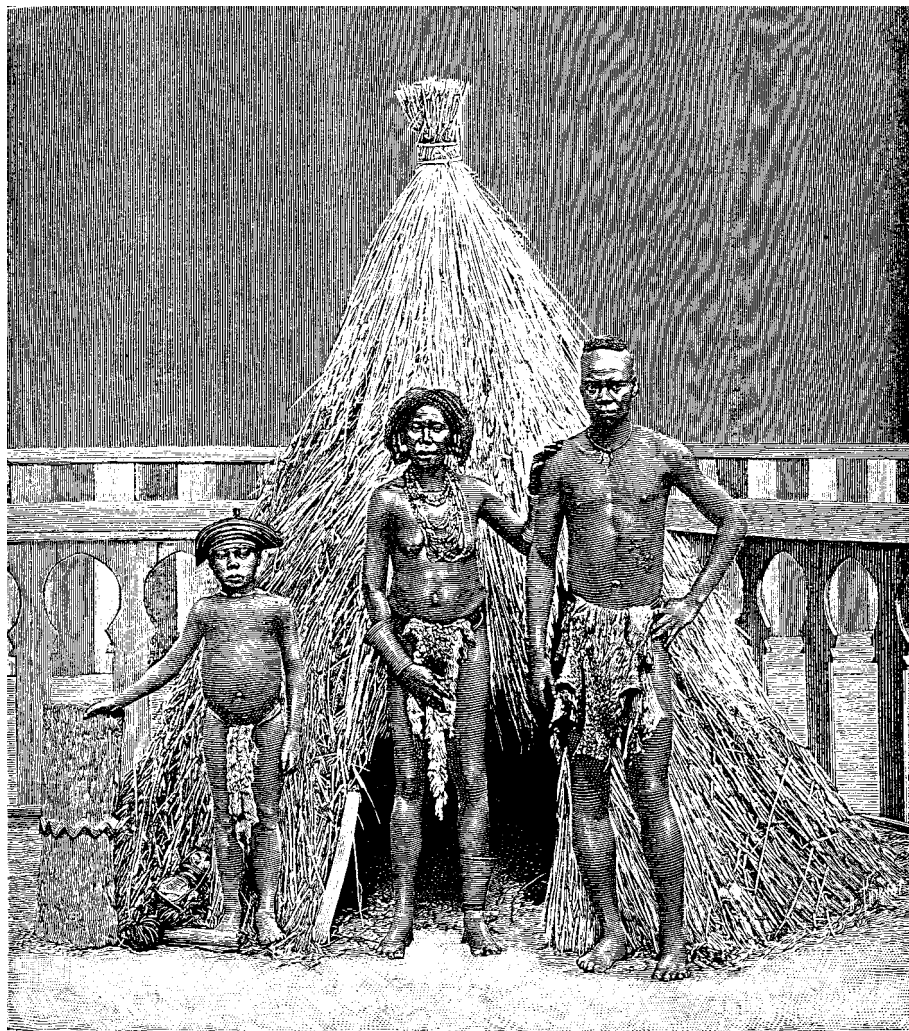

Illustration from La Nature, 1889. Original caption reads: "Man, woman, and child from the band of Angolans exhibited at the Paris Exposition."



Le gladiateur



Le mal de dents

Hypnotized subjects: one believes he is a gladiator; the other that he has a toothache. Late 1880s.

music hall and proto-vaudeville acts.¹⁹⁴ In fact, many of the important researchers associated with hypnosis in the nineteenth century, including Braid, Charcot, Freud, and the American psychologist G. Stanley Hall, were first exposed to hypnotic practices through such “theatrical” displays and, notably, were convinced by them that there was something important and authentic to study further.¹⁹⁵ One of the best-known hypnotist-showmen was the Dane Carl Hansen, whose performances were seen across Europe between 1879 and 1884, and his audiences at various times included Bernheim, Freud, Wundt, and Krafft-Ebing, among others.¹⁹⁶ Hansen’s entertainment included compelling his subjects to assume cataleptic postures, as well as “engaging in preposterous pantomimes, standing up and singing, eating a raw potato believing it to be a pear; and drinking imaginary champagne from real glasses and thereafter behaving as if intoxicated.”¹⁹⁷ Essential here is the incommensurability of a hypnotic transaction viewed externally *as spectacle*, a transaction in which domination over passivity seems implicit, and the inner or subjective reality of a psychic state which could in fact involve resistance and evasion of external authority.¹⁹⁸ Historically, the importance of public demonstrations

194. By the mid-1880s there was increasing debate about the suitability of hypnosis as a public entertainment. Note, for example, the ambivalence in this 1889 account: “Public exhibitions have called the attention of science to these states, though on the other hand the flavor of charlatanism in the matter has repelled many. For this reason it is a good thing that such public exhibitions have been forbidden in Prussia. Nothing now prevents our approaching the subject in a scientific manner. I do not wish to deprecate the services of those who have drawn attention to hypnotism by public exhibitions. Just as I refuse to join in the general condemnation of Mesmer, I try to judge men such as Hansen, Bollert and others, fairly. Though their motives may not have been purely unselfish, they have been of great service to science. . . . However, it must be added that, from the moral point of view, there is no justification for putting people in a condition which deprives them of their will for no higher object than the amusement of uncultured persons.” Albert Moll, *Hypnotism* (1889; New York: Scribner’s, 1899), pp. 391–392. A more denunciatory attitude toward traveling Mesmerists and hypnosis showmen, including a demand for legal restraint, can be seen in Georges Gilles de la Tourette, *L’hypnotisme et les états analogues au point de vue medico-legal* (Paris: E. Plon, 1887).

195. On Braid, Charcot, and Freud, see Leon Chertok and Raymond de Saussure, *The Therapeutic Revolution, from Mesmer to Freud*, trans. R. H. Ahrenfeldt (New York: Brunner/Mazel, 1979), p. 38. Hall “had been introduced to the subject [of hypnosis] in Germany by popular demonstrators claiming spiritualist powers”: Dorothy Ross, *G. Stanley Hall: The Psychologist as Prophet* (Chicago: University of Chicago Press, 1972), p. 149. Braid’s early exposure to Lafontaine’s seances is discussed in Carroy, *Hypnose, suggestion et psychologie*, pp. 91–92.

196. See Bernheim’s insistence on Hansen’s authenticity (even though he describes him as “a man unacquainted with medicine”) in *Hypnosis and Suggestion in Psychotherapy* (1884; New York: Aronson, 1973), pp. 120–121.

197. Alan Gauld, *A History of Hypnotism* (Cambridge: Cambridge University Press, 1992), p. 303. See also the account in J.-S. Morand, *Le magnétisme animal: Etude historique et critique* (Paris: Garnier, 1889), pp. 425–428.

198. For François Roustang, hypnosis is a radically other form of wakefulness that is incompatible with Western notions of consciousness. It is a wakefulness in which the loss of self-mastery, of the ability to make decisions and reflect, is a new modality of freedom. Of the thousands of characteristics of a

of “magnetization” is not whether they were staged or simulated, like some of Charcot’s exhibitions or others (evidence suggests that most were not fraudulent). Rather, they provided a set of powerful images of a hypnotic experience that defined it as an event or object from which a truth could be extracted objectively, from the outside. In the same way, various displays and representations of the “primitive” posed non-Western subjects as objects of fascination and objects susceptible to mastery and classification. The nineteenth-century exhibitions were part of a world in which people “were beginning to live as tourists or anthropologists, addressing an object-world as the endless representation of some further meaning or reality . . . but *reality*, it turns out, means that which can be represented, that which presents itself as an exhibit before an observer. The so-called real world outside is something experienced and grasped only as a series of further representations, an extended exhibition.”¹⁹⁹

Parade de cirque itself shows us another contemporary phenomenon of display and entertainment. Recent historians of art emphasize that the painting is most likely a representation of the Cirque Corvi as it was situated for several months in the fairgrounds at the Place de la Nation in 1887.²⁰⁰ To belabor this specific identity is to ignore the obvious: the thoroughness with which Seurat has abstracted specific references to any particular site into a generic image of the urban fairground and circus in the second half of the nineteenth century, a form of entertainment at the tail end of a long process of domestication and commodification. But the issue here is more than just the reification of popular culture. As some critics have insisted, carnival and popular festival did not simply disappear in the nineteenth century but rather were dispersed in various “fragmented, marginalized, sublimated, and repressed forms.”²⁰¹ In this sense, the site of *Parade de cirque* is highly

hypnotic experience, he says, some are the following: “the cohabitation or coidentity of contrary qualities, of hot and cold, of suppleness and rigidity, light and darkness, closed space and openness, hypersensibility and anesthesia, communication and closing off, concentration and relaxation, attention and distraction. An initial conclusion seems obvious: the hypnotic state has no use for the categories of space and time.” Roustang, *Influence* (Paris: Editions de Minuit, 1990), p. 84. See also the assertion that “hypnotic existence is formless,” in Jean-Luc Nancy, *The Birth to Presence*, trans. Brian Holmes (Stanford: Stanford University Press, 1993), pp. 19–23.

199. Timothy Mitchell, “The World as Exhibition,” *Comparative Studies in Society and History* 31 (1989), pp. 232–233.

200. The Cirque Corvi identification is due less to recognizable features in *Parade de cirque* than to remarks made by Gustave Kahn in his review of the work in “Peinture: Exposition des Independantes,” *Revue independante*, n.s. 7, no. 18 (April 1888), p. 161. Jean-Claude Lebensztejn insists on the irrelevance of such specificity and argues for the importance of an anonymous decontextualization in Seurat’s work, in *Chabut*, p. 31.

201. This is part of the important argument made in Peter Stallybrass and Allon White, *The Politics and Poetics of Transgression* (Ithaca: Cornell University Press, 1986), p. 178.



Hypnosis as theatrical exhibition, late 1880s.

“mixed”: on one hand it stands for the commercialization of what were once more nomadic and popular forms, but on the other it is an “enclaved environment for the controlled de-control of the emotions, where adults are given permission to behave like children again,” an arena of “ordered disorder.”²⁰² As such, *Parade de cirque* is a figuration of a social territory where techniques of fascination and attraction, of appearance and semblance, have the capacity to overpower an observer or audience, even as a psychological regression. Beginning in the late 1880s, also, fairgrounds and related spaces included new kinesthetic experiences such as ferris wheels, roller coasters, slides, and loop-the-loops. Within these “controlled” circumstances the inciting of dynamogenic bodily sensations, for example on a merry-go-round, was a fragmentary and mechanical recuperation of carnival energies.²⁰³ Needless to say, during the next decade and a half, it was on this same social terrain of the fairground that another kinematic form of visual fascination implanted itself. Cinema would radically displace survivals of premodern forms like the circus, but would also powerfully constitute itself as a related “enclave” for different modes of regression and fantasy.²⁰⁴

We can now begin to ask more specifically how the painting might be a figuration on a representational level of the very operations that it deploys (at

202. Mike Featherstone, “Postmodernism and Aestheticization,” in Scott Lash and Jonathan Friedman, eds., *Modernity and Identity* (Oxford: Blackwell, 1992), p. 284. Featherstone sees nineteenth-century fairs, music halls, spectacles and late twentieth-century tourism, theme parks, malls as related forms of “constructed otherness.”

203. See the valuable discussion on the late nineteenth-century shift from “viewing machines” to “vertigo machines” in Lieven de Caeter, “The Panoramic Ecstasy: On World Exhibitions and the Disintegration of Experience,” *Theory, Culture, and Society* 10 (November 1993), pp. 1–23. See also the account of a broad emergence of a kinesthetic material culture at the turn of the century in Hillel Schwartz, “Torque: The New Kinaesthetic of the Twentieth Century,” in Crary and Kwinter, eds., *Incorporations*, pp. 71–126.

204. The critical writings of Raymond Bellour have been important for me, in particular his outlining of interrelations between photography, hypnosis, cinema, and psychoanalysis in the nineteenth century: “These are the signs of a very strong epistemological configuration which assigned a rather new place to the subject in Western culture—a place that was increasingly linked to the formation of certain images of time, of the past and of memory. Throughout the nineteenth century, we can in fact see the gradual formation of a very important, very powerful image making tendency that became radicalized at the end of the century by two inventions which seem to have inherited, each on its own level, all of the elements that were crystallizing during those years around hypnosis, both medically and mythically. One was a mechanical invention that made possible for the first time the imaginary reproduction of movement and life; the other was a psychological theory which explained the destiny of the human subject in terms of the formation of a set of representations, of phantasies, and in terms of the subject’s attachment to certain images.” From Janet Bergstrom, “Alternation, Segmentation, Hypnosis: An Interview with Raymond Bellour,” *Camera Obscura* 3–4 (Summer 1979), p. 102. Also, Bellour’s essay on Jacques Tourneur’s masterpiece *Curse of the Demon* (1957) is a superlative meditation on cinema, hypnosis, and fascination; see Bellour, “Believing in the Cinema,” in E. Ann Kaplan, ed., *Psychoanalysis and Cinema* (New York: Routledge, 1990), pp. 98–109.

least in principle) on a molecular level through the psychomotor effects of certain chromatic and directional stimuli.²⁰⁵ I've already mentioned that one aspect of the quasi-system of dynamogeny and inhibition was its relation to hypnosis. Brown-Sequard explicitly insisted that the work of James Braid (with whom the modern study of hypnosis begins) was decisive in his own formulation of these concepts. What Braid described was the special power of the nervous system of hypnotized individuals to manifest very suddenly a heightening of motor activity in a certain localized part of the body.²⁰⁶ For Brown-Sequard, hypnosis was a major example of how dynamogenic effects inhibit large areas of an individual's functioning while only very circumscribed areas are stimulated.²⁰⁷ Hippolyte Bernheim cited Brown-Sequard's conclusion as important for his own work: "Hypnotism is then essentially only the collective effect of acts of inhibition and of dynamogeny"; and for Charles Henry hypnotism overwhelmingly demonstrated that perception was fundamentally unconscious, consisting of involuntary responses to stimuli.²⁰⁸ What is important here, and particularly in terms of Seurat's relation to these ideas, was a fundamental *indistinction* between the automatism of a hypnotized subject and the perceptual experience of a so-called "normal" subject.

The question then remains: what does it mean to read this image of audience and spectacle through the contemporary social phenomena of suggestion and somnambulism? Clearly *Parade de cirque* operates on several levels through "a bypassing of intellectual processes," such as reason and judgment, in an attentive spectator.²⁰⁹ Seurat's practice makes explicit a radical and *calculated* disparity between the rationalized construction of an image and the subrational response of its observer. Bergson, around the same time, was describing the proximity of art and hypnosis: "In the processes of art we shall find, in a weakened form, a refined and in some measure spiritualized version of the processes commonly used to induce the state of hypnosis. . . . The plastic arts obtain an effect of the

205. *Parade de cirque* is described as Seurat's "most thorough attempt to control the spectator's emotions subconsciously by the disciplined devices of his art," in Thompson, *Seurat*, p. 152.

206. James Braid, *Neurypnology, or the Rationale of Nervous Sleep Considered in Relation with Animal Magnetism* (London: J. Churchill, 1843). Brown-Sequard wrote a preface to the 1883 French edition of this work.

207. Brown-Sequard, "Dynamogenie" (1885), p. 757. The relation between dynamogeny and hypnosis is also discussed in Moll, *Hypnotism*, pp. 292–293.

208. Bernheim, *Hypnosis and Suggestion in Psychotherapy*, p. 138; and Henry, "Le contraste, le rythme, la mesure," pp 358–362.

209. Bernheim, *Hypnosis and Suggestion in Psychotherapy*, p. 137.

same kind by the fixity which they suddenly impose upon life, and which a physical contagion carries over to the attention of the spectator.”²¹⁰ In the late 1880s and 1890s many different discourses considered the ways in which external forces and procedures could influence or control both individual and collective subjects. As has been noted often, one common notion in French sociological thinkers as different from each other as Durkheim, Gabriel Tarde, and Gustave Le Bon is that the primal fact of social life is some system of control or coercion that is imposed on the individual. As discussed above, aspects of Seurat’s own practice were informed by physiological knowledge about the production of specific emotional responses. But in his last works, with their images of groups of spectators, the preoccupations with visual and chromatic mechanisms of stimulus and inhibition connect with an interest in the dynamics of social spaces in which other techniques of control could be exercised. Over a decade before Simmel published his famous essay on the metropolis and mental life, Tarde made observations about modern forms of attentiveness that are directly relevant to *Parade de cirque* and *Cirque*:

In this singular condition of intensely concentrated attention, of passive and vivid imagination, these stupefied and feverish beings inevitably yield themselves to the magical *charm* of their new environment. They believe everything that they see, and they continue in this state for a long time. It is always more fatiguing to think for oneself than to think through the minds of others. Besides, whenever a man lives in an animated environment, in a highly strung and diversified society which is constantly supplying him with fresh sights, with new books and music and with constantly renewed conversation, he gradually refrains from all intellectual effort; his mind, growing more and more stultified and, at the same time, more and more excited, becomes, as I have said, somnambulistic. Such a state of mind is characteristic of many city dwellers. The noise and movement of the streets, the display of the shop windows, and the wild unbridled rush of existence affect them like magnetic passes. Now, is not city life like a concentrated and exaggerated type of social life?²¹¹

210. Bergson, *Time and Free Will*, pp. 14–15.

211. Gabriel Tarde, *The Laus of Imitation* (1890), trans. E. C. Parsons (New York: Henry Holt, 1903), p. 84.

According to some, the audience in *Parade de cirque* has the signs of a distracted crowd, the crowd as a rootless urban phenomenon that finds itself briefly, almost by chance, before the sideshow. Certainly Seurat does not show us a group of spectators characterized by undivided attention, but at least six of these figures, whose silhouettes can be categorized as frontal, are presented fully facing the stage. Of these six possibly attentive figures, the most significant is the male figure fifth from the left. He is isolated somewhat from the rest of the crowd by his elevated position, which in turn emphasizes his rigid frontality. At the same time there is a general identity (if this can be said of figures so relentlessly characterless and generic) between this man and the musicians on the left of the stage, both in terms of dress and posture. It's possible to read this figure as immobile and deeply absorbed, as if in the grip of a silent private communion, as if some initiate in league with his counterparts on stage.²¹² It is a figure who imparts a sense of being elect even in the midst of urban anonymity, even a figuration of what Mikkel Borch-Jacobsen unsparingly describes as “homo democraticus or ‘man without qualities,’ without his own identity, brutally revealed by the retreat of the great transcendent political and religious systems, who is no longer a subject . . . the deeply panicked, de-individualized, suggestible, hypnotizable being of the lonely crowd.”²¹³ If such a reading of this figure is tenable, then there is no reason why it might not also apply to other adjacent members of the crowd, say the woman with the tall hat fourth from the right or even the man shown in profile in the bottom left corner.

But at the same time it's entirely possible to read the relation between this figure and the musicians as one of “imitation,” as this concept was developed in the work of Tarde in the 1880s. Tarde, as we know, posed a very different explanatory scheme for the understanding of social cohesion from that of Durkheim. At the heart of his work was the notion that “society could not exist or change or advance a single step unless it possessed an untold store of blind routine and slavish

212. In this sense, a new modernizing instrumentality is fulfilling here (at least superficially) the same functions that Michael Fried identified as part of anti-rococo French painting: “A painting, it was claimed, had first to attract (*attirer*, *appeller*) and then to arrest (*arreter*) and finally to enthrall (*attacher*) the beholder, that is, a painting had to call to someone, bring him to a halt in front of itself, and hold him there as if spellbound and unable to move.” Fried, *Absorption and Theatricality: Painting and Beholder in the Age of Diderot* (Berkeley: University of California Press, 1980), p. 92.

213. Mikkel Borch-Jacobsen, *The Emotional Tie: Psychoanalysis, Mimesis, and Affect* (Stanford: Stanford University Press, 1992), p. 26. Robert Herbert associates this figure with the visual types that were later to populate the paintings of Magritte, in his “Parade de cirque” de Seurat et l'esthétique scientifique de Charles Henry,” p. 18. See also the related discussion in Paul Smith, *Seurat and the Avant-Garde*, pp. 124–125.

imitation which was constantly being added to by successive generations.”²¹⁴ “Social self-organization” was propagated, according to Tarde, not by laws or civic institutions but by processes of imitative repetition: “society may be defined as a group of beings who are apt to imitate one another.”²¹⁵ The engine of this “social mystery” of imitation was, at a molecular level, the influence of one person on another, that is, the phenomenon of suggestion. Tarde unhesitatingly equated social existence with somnambulism, that is, with a state characterized by heightened receptivity to suggestion. Le Bon and others noted hypnotic aspects of the life of crowds, but Tarde went much further: “I shall not seem fanciful in thinking of social man as a veritable somnambulist. . . . The social, like the hypnotic state, is only a form of a dream.”²¹⁶ He details the historical development of different regimes of imitation and suggestion, from despotic authority which operated through effects of prestige, what he called “la suggestion prestigeuse,” to modern societies in which the operations of conformity and suggestion have multiplied and dispersed far beyond the single circuit of charismatic ruler and docile subject.²¹⁷ New media and means of mass communication were central to his investigations.²¹⁸

Tarde was constantly identifying functional parallels between individual subjective behavior and the actions of large social collectivities, but one of his most suggestive analogies was visual. He invoked Helmholtz’s account of entoptical phenomena to indicate how an individual was fundamentally inattentive to an enormous amount of sensory experience: “At each instant we are assailed and troubled by ocular sensations such as the *mouches volantes*, which if we always noticed them, if our ego [moi] received them into consciousness [elite], would prevent any judgment of location or systematic organization of retinal impressions.”²¹⁹ We also never hear the low-level buzzing that is continually in our ears, nor are usually aware that we are continually traversed by sensations of all kinds. Social consciousness, he insists, is much the same: it operates according to a related principle of narrowed attentiveness and exclusion, through which a vast amount of

214. Tarde, *The Laws of Imitation*, p. 75. The sections of this book I have cited were published in periodical form in 1884.

215. Tarde, *The Laws of Imitation*, p. 68.

216. *Ibid.*, pp. 76–77.

217. Gabriel Tarde, “Categories logiques et institutions sociales,” *Revue philosophique* 28 (August 1889), p. 123.

218. See Serge Moscovici, *The Age of the Crowd: A Historical Treatise on Mass Psychology*, trans. J. C. Whitehouse (Cambridge: Cambridge University Press, 1985), p. 158. One of Tarde’s basic arguments was “the primacy of the means of communication over all the instruments of social life.”

219. Tarde, “Categories logiques et institutions sociales,” p. 302.

social inventions, memories, discoveries fall into oblivion as they disappear from the foyer of “the social retina.”²²⁰

Tarde’s phrase is appropriate for *Parade de cirque*, where there is an overlapping of an individual physiological retina and a social one. Take, for example, the relation between the aforementioned attentive figure and the four musicians at the left: it is not simply a connection between audience and performers in which the latter are observed by the former. Rather it’s possible to read an *imitative* relation there as well: the outline of a simple mechanism of social conformity. Various imitative relations, for Tarde, were at the heart of social cohesion, relations founded on an innate tendency to mimicry in the nervous system. He sometimes called it “intercerebration,” to describe the relation between two brains “one of which fascinates the other”; “this relation consists of a special polarisation in the latter of the belief and desire which are stored up in each of its elements.”²²¹ One can examine other features of *Parade de cirque* for related operations of this “social retina,” such as the row of spectators at the bottom: the line of heads diagrams the diffuse nature of imitative social mechanisms, what Tarde called “fashion-suggestibility.” By this he meant to describe how half-conscious observation and mere physical proximity produce (even within the obvious diversity of this assemblage) a *functional* social homogeneity, indicated here by the looks exchanged by members of the crowd and by the redundancy of a limited number of hat styles, hairstyles, not to mention a loosely shared absorption in the spectacle.²²² At issue is how modern social cohesion was essentially a kind of mental cohesion resulting from countless “contagion-like” processes of transmission, for Tarde proposed the notion “that the progress of civilization renders subjection to imitation at once more personal and more rational.”²²³ This might also provide a way of reading the puzzling treatment of the audience in *Cirque* a few years later: the reductive, almost cartoonlike depiction of this audience may have been a way of sardonically revealing processes of imitation and mimicry that operate both within and beyond the distinctions of social class.²²⁴ It has long been noted that these figures are built

220. Ibid., p. 303.

221. Tarde, *The Laws of Imitation*, p. 88.

222. For an extended discussion of Tarde and the emergence of consumerism, see Rosalind Williams, *Dream Worlds: Mass Consumption in Late Nineteenth Century France* (Berkeley: University of California Press, 1982), pp. 342–384.

223. Tarde, *The Laws of Imitation*, p. 83.

224. “So-called popular wishes, the aspirations of a small town, for example, or of a single class, are composed exclusively, at a given moment, of tendencies . . . to ape in all particulars some richer town or some superior class. This body of simian proclivities constitutes the potential energy of a society.” Ibid., pp. 106–107.

up out of dynamogenic elements (the diagonals and V shapes of hair, clothing, eyes, moustaches): that is, Seurat has embedded into his representation of the crowd his own mechanisms for the production of “contagious” emotional effects. At the same time, the vertical layering of these seated spectators according to social class in *Cirque* might be similar to what Tarde called “terraces of consecutive magnetisations.” “If every society stands forth as a hierarchy,” he wrote, “it is because every society reveals the terracing of which I have just spoken, and to which, in order to be stable, its hierarchy must correspond.”²²⁵ Yet if in both *Cirque* and *Parade de cirque* there is an indication of a diffuse and reciprocal suggestibility operating within the crowd, both paintings also depend on the symbolic presence of a central, perhaps controlling figure, perhaps a “grand magnetiseur,” who would, according to Tarde, occasionally make an appearance within modern society. Tarde clearly believed in such “atavistic phenomena,” that is, the collective survival of archaic forms of social behavior, and that modern individuals were deluded to think themselves immune to the oldest “effects of obedience and imitation through fascination. Is not fascination,” he asks, “a genuine neurosis, a kind of unconscious polarization of love and faith?”²²⁶ Attention, Tarde had written, was fundamentally disconnected from an empirical act of vision, and instead he defined it as the transformation of sensation by effort and desire: attention “is the desire for an increase in present belief.”²²⁷

225. Tarde, *The Laws of Imitation*, pp. 84–85. The mixture of social and geological metaphors is one of the many reasons why Deleuze and Guattari championed Tarde in their *A Thousand Plateaus*, pp. 218–219. For these authors, Tarde was the inventor of microsociology, who, unlike Durkheim, “was interested instead in the world of detail, or the infinitesimal: the little imitations, oppositions, and inventions constituting an entire realm of subrepresentative matter.” Tarde, for whom “molecular” is a key term, understood that “beliefs and desires are the basis of every society, because they are flows and as such are ‘quantifiable’; they are veritable social Quantities, whereas sensations are qualitative and representations are simple resultants.” Oddly, in spite of their partisanship on his behalf, Deleuze and Guattari do not, to my knowledge, seem ever to have identified Tarde as one of the sources for their concept of the “plateau” (which they affiliate with the work of Bateson). Tarde uses “plateau” as a flexible figure for natural, social, and statistical processes and events, including the operation of “social desire.” See *The Laws of Imitation*, pp. 116–127.

226. Tarde, *The Laws of Imitation*, p. 80.

227. Gabriel Tarde, “Belief and Desire,” in *On Communication and Social Influence: Selected Papers of Gabriel Tarde*, ed. Terry N. Clark (Chicago: University of Chicago Press, 1969), pp. 197–198. This essay was originally published in *Revue philosophique* in 1880. In it Tarde suggests some of the epistemological problems that were to become crucial in Seurat’s work: “More important than making a definition of this type is to note that belief, no more than desire, is neither logically nor psychologically subsequent to sensation; that, far from arising out of an aggregate of sensations, belief is indispensable both to their formation and their arrangement; that no one knows what remains of sensation once judgment is removed; and that in the most elementary sound, in the most indivisible colored point, there is already a duration and a succession, a multiplicity of points and contiguous moments *whose integration is an enigma*.” (Ibid.; emphasis added.)

Le Bon's *La psychologie des foules* (1895) became the best known of a large body of work on crowd psychology in the late 1880s and 1890s, and it has been discussed at length by many commentators.²²⁸ Less frequently noted, however, is the way in which Le Bon portrays the crowd as a particular modality of perception, as a specific social arrangement that conditions the limits of perceptual experience. This interest in the boundaries of human perception was also part of his later amateurish investigation of X rays and other forms of radiation outside the visible wavelengths of the spectrum.²²⁹ Writing in the early 1890s, Le Bon posed the modern crowd as a viewing machine, capable of generating "collective hallucinations," either through its internal actions or at the prompting of an external manipulator. The crowd in Le Bon is a generalized site on which the accumulated dread and hope associated in the nineteenth century with social insurrection collapse into an abstract contentless mass onto which dream imagery of any sort can be projected. He reconceives the crowd as a place for the consumption of illusion.

One of the characteristics of the crowd, according to Le Bon, is that once an individual is subsumed in it, he or she becomes "incapable of observation . . . the faculty of seeing becomes destroyed."²³⁰ But he insists at the same time that a crowd "thinks in images. . . . It accepts as real the images evoked in its mind, though they most often have only a very distant relation with the observed fact."²³¹ Le Bon the political thinker intuits the essence of modern spectacular culture, which Guy Debord was to articulate seven decades later: "wherever representation takes on an independent existence, the spectacle reestablishes its rule."²³² For Le Bon "observation" refers to a cognitive model predicated on a workable notion of objective reality, essentially a classical epistemological model but one that begins to corrode within a field saturated by illusion, hallucination, and whole industries of simulation. Le Bon also proposes a flexible and far from literal notion of what

228. On earlier lesser-known studies on crowd psychology see Jaap van Ginneken, "The 1895 Debate on the Origins of Crowd Psychology," *Journal of the History of the Behavioral Sciences* 21 (October 1985), pp. 375–382.

229. See Mary Jo Nye, "Gustave Le Bon's Black Light: A Study in Physics and Philosophy in France at the Turn of the Century," *Historical Studies in the Physical Sciences*, ed. Russell McCormach, vol. 4 (Princeton: Princeton University Press, 1974), pp. 163–196. This article discusses, among other things, Le Bon's early medical training, his contentious exchanges with the Lumiere brothers, and his correspondence with Albert Einstein in the 1920s.

230. Gustave Le Bon, *The Crowd* (1895; New York: Viking, 1960), pp. 42–43.

231. *Ibid.*, p. 41.

232. "For one to whom the real world becomes real images, mere images are transformed into real beings—tangible figments which are the efficient motor of trancelike behavior." Guy Debord, *The Society of the Spectacle*, trans. Donald Nicholson-Smith (New York: Zone Books, 1994), p. 17.

constitutes a crowd. His concern is not the physical accumulation of large numbers of people in a single place but rather aggregations of people who in fact may occupy spatially remote locations but nonetheless constitute an effective *psychological* unity. His “law of the mental unity of crowds” certainly anticipates the collectivities that will be conjured up by all the telecommunicative and televisual apparatuses of the twentieth century. Le Bon writes that “thousands of isolated individuals may acquire at certain moments, and under the influence of certain violent emotions—such as a great national event—the characteristics of a psychological crowd.”²³³ But, he continues: “At certain moments half a dozen men might constitute a psychological crowd,” an observation clearly useful to an analysis of Seurat’s *Parade de cirque*. Le Bon reinvents the idea of the crowd as a way of identifying and accounting for new forms of social composition and, in contrast to Durkheim, indicating how unstable and potentially dangerous social aggregates are held together in order to manage them.²³⁴

Most significantly Le Bon emphasizes that a crowd, by definition, is “in a state of expectant attention, which renders suggestion easy.”²³⁵ Le Bon acknowledges here, as did many researchers during the late nineteenth century, the uncertain and fluid relation between hypnosis and attention. Important and unprecedented is the assumption that attention has no necessary connection to objective optical observation of the world, that attention can subsist outside of what Le Bon calls the faculty of seeing. Le Bon was an influential part of a tradition of crowd psychology that deployed an explanatory model of “regression,” that saw in the crowd a drift toward a more primitive order of consciousness, a shift to “lower” cerebral functions, analogous to infantilism or savagery. Part of this process is the withdrawal of one’s attention from one’s surrounding environment and its refocusing on some real or symbolic figure (for Le Bon and later for Freud, the charismatic figure of the leader or chief) with whom the individual establishes a fundamental

233. Le Bon, *The Crowd*, p. 24.

234. It should be noted that Le Bon’s notion of the crowd is remote from Durkheim’s ideas about social aggregates. Le Bon saw the crowd as an example of how groups could become completely detached from the social substrate of morality and cultural practices, which Durkheim felt were still present even in crowd situations. On the crowd in Durkheim, Tarde, and Le Bon, see Charles Lindholm, *Charisma* (Oxford: Blackwell, 1990), pp. 27–49. See also Catherine Rouvier, *Les idées politiques de Gustave Le Bon* (Paris: Presses universitaires de France, 1986), pp. 100–102; Susanna Barrows, *Distorting Mirrors: Visions of the Crowd in Late Nineteenth Century France* (New Haven: Yale University Press, 1981), pp. 162–188; and Patrick Brantlinger, *Bread and Circuses: Theories of Mass Culture as Social Decay* (Ithaca: Cornell University Press, 1983), pp. 154–183.

235. Le Bon, *The Crowd*, p. 39.

rapport (or surrender).²³⁶ But in the context of multiplying forms of spectacle in the 1890s, including early cinematic experience, it is interesting to consider Le Bon's identification of a theatrical configuration as the most powerful means for controlling a crowd: "Nothing has a greater effect on the imagination of crowds of every category than theatrical representations. The entire audience experiences at the same time the same emotions."²³⁷ Nietzsche had already made a related observation about the nature of a modern audience: "No one brings his finest senses of art to the theater, nor does the artist who works for the theater. . . . There the most personal conscience is vanquished by the leveling magic of the great number; there, stupidity has the effect of lasciviousness and contagion; the neighbor reigns, one becomes a mere neighbor."²³⁸ Le Bon's text, then, is merely one indication of how the image of theater exceeded its older place within models of mimetic relations and was used as spatial figure for new effects of subjectification. Seurat's paintings, too, use the notion of theater as a figure that can describe both collective public experiences, such as ones literally depicted in his paintings, and also individuated experiences produced by the management of perception in terms of a solitary subject.



Perhaps the most significant cultural phenomenon in the second half of the nineteenth century where problems of theater, spectacle, and techniques of psychological control come together is in the operatic work of Richard Wagner.²³⁹ Even after his death in 1883, Wagner's aesthetic legacy was inseparable from problems of both perceptual attentiveness and social cohesion.²⁴⁰ For any artist at that

236. Freud's extended discussion of Le Bon's "brilliant" and "deservedly famous" work is in his *Group Psychology and the Analysis of the Ego* (1921), trans. James Strachey (New York: Norton, 1959), p. 12: "And, finally, groups have never thirsted after truth. They demand illusions, and cannot do without them. They constantly give what is unreal precedence over what is real; they are almost as strongly influenced by what is untrue as by what is true."

237. Le Bon, *The Crowd*, p. 68.

238. Friedrich Nietzsche, *The Gay Science* (1882), trans. Walter Kaufmann (New York: Vintage, 1974), p. 326 (sec. 368). Nietzsche elsewhere remarked, "Our entire sociology does not know any other instinct than that of the herd, i.e., that of *the sum of zeroes*—where every zero has 'equal rights,' where it is virtuous to be zero." *The Will to Power*, p. 33 (sec. 53); emphasis in original.

239. The precise nature of Seurat's clear interest in Wagner's work has been a matter of much speculation. He associated with some of the most prominent Wagnerians in Paris, including the principals behind the *Revue wagnerienne*, which was published between 1885 and 1888. For accounts of Seurat's relation to contemporary Wagnerism, see Zimmermann, *Seurat and the Art Theory of His Time*, pp. 307–311, and Smith, *Seurat and the Avant-Garde*, pp. 123–140.

240. The indispensable work on Wagner and mass culture is Theodor W. Adorno, *In Search of Wagner*, trans. Rodney Livingstone (London: Verso, 1981). See also the valuable discussion in Andreas Huyssen, "Adorno in Reverse: From Hollywood to Richard Wagner," in *After the Great Divide: Modernism, Mass*

time, whether visual or literary, Wagner's work itself, as well as the extravagant claims that were being made on its behalf, posed what Mallarmé called a "singular challenge." Not only did the example of Wagner put in question the priority of the individual arts of poetry and visual representation, but it suggested the outlines of a collective cultural experience that Wagner himself compared with festival theater in Greek antiquity. Beginning in the 1840s and evolving confusedly for the rest of his life, Wagner's social critique had nothing particularly original about it within a broader field of nineteenth-century indictments of the effects of social and economic modernization. What remains singular about Wagner was the relative specificity of his cultural program for social reintegration and his belief in the transformative effects of the *collective* experience of music drama performed and produced as a ritual communal event.²⁴¹ In connection with the problems of social aggregates and solidarities in Durkheim and Seurat, it is important to understand how much Wagner's work was linked to the problem of community formation, of welding individuals into a social unity, by imposing a uniform mode of perception and response, even if it was in terms of *volksish* homogeneity.²⁴² As Marc Weiner has argued, vision had an extraordinary primacy for Wagner. Opera, emulating Greek tragedy, was for him a mirror in which a community could see itself reflected. "The optical metaphor of the theatrical experience is thus based upon the notion that the sense of vision serves to reinforce one's place within the social whole."²⁴³

By the middle of the century Wagner had already framed part of his cultural critique around the issues of attention and distraction. Prefiguring some early twentieth-century debates about the effects of mass culture which articulated distraction as a term opposed to a self-conscious contemplative perception, Wagner deplored the pervasiveness of distracted modes of cultural consumption.²⁴⁴ In the

Culture, Postmodernism (Bloomington: Indiana University Press, 1986), pp. 16–43; and Friedrich Kittler, "World Breath: On Wagner's Media Technology," in David J. Levin, ed., *Opera through Other Eyes* (Stanford: Stanford University Press, 1994), pp. 215–235.

241. One of Wagner's exemplary explanations of the degradation of contemporary theater and opera in terms of their disconnection from the life of a community is contained in "A Theater at Zurich" (1851), in *Judaism in Music and Other Essays*, pp. 25–57. The persistence of these Wagnerian social ambitions is described in the context of Gustav Mahler's circle in 1890s Vienna in William J. McGrath, *Dionysian Art and Populist Politics in Austria* (New Haven: Yale University Press, 1974), pp. 120–164.

242. For an important discussion of the problem of community formation in Wagner, see David J. Levin, "Reading Beckmesser Reading: Antisemitism and Aesthetic Practice in *The Mastersingers of Nuremberg*," *New German Critique* 69 (Fall 1996), pp. 127–146.

243. Marc Weiner, *Richard Wagner and the Anti-Semitic Imagination* (Lincoln: University of Nebraska Press, 1995), p. 36.

244. See, for example, Wagner's remarks on receptiveness and distraction in "Public and Popularity," in *Religion and Art*, trans. W. Ashton Ellis (Lincoln: University of Nebraska Press, 1994), pp. 62–64.

context of music he made a distinction between “higher” (deeply attentive) and “lower” (distracted) forms of listening and clearly advocated the former as purified and ethically superior perceptual engagement. His critique of French and especially Italian opera noted how works were composed around a few brilliant arias that would attract an audience’s attention for their brief duration, while for the balance of the performance this attention was distracted or engaged elsewhere. Wagner’s conception of a German opera postulated an audience capable of sustained and *continuous* attention through an entire performance.²⁴⁵ More specifically, one of Wagner’s frustrations with the experience of grand opera and theater in the mid-nineteenth century was the problem of spectators who were given multiple points of attraction.²⁴⁶ He was dissatisfied with traditional theater design, which had long allowed (or encouraged) audiences to look at each other, at the orchestra, at the diverse social texture of the theater (which was the case with the variety-show formats of early cinema as well).²⁴⁷ The physical plan of Bayreuth was, in part, the outcome of Wagner’s desire to exercise a fuller control over the

245. Richard Wagner, “Zukunftsmusik” (1861), in *Judaism in Music and Other Essays*, p. 332: “In the Opera-house of Italy there gathered an audience which passed its evenings in amusement; part of this amusement was formed by the music sung upon the stage, to which one listened from time to time in pauses of the conversation; during the conversation and visits paid from box to box the music still went on, with the same office one assigns to table music at grand dinners. . . . An opera must contain at least *one* aria to which one is glad to listen; if it is to have a success, the conversation must be broken, and the music listened to with interest, at least six times; whilst the composer who is clever enough to attract the audience’s attention a whole twelve times, is lauded as an inexhaustible melodic genius.” See also Wagner, *Opera and Drama*, trans. W. Ashton Ellis (Lincoln: University of Nebraska Press, 1995), pp. 128–129, where Wagner insists on the necessity of spectators who will give “continuous and undivided attention to a fascinating subject.”

246. Wagner’s critique was preceded by Schopenhauer’s even more thorough dismissal of nineteenth-century opera as a form synonymous with distraction: “Indeed, to be properly interpreted and enjoyed, the highest productions of music demand the wholly undivided and undistracted attention of the mind so that it may surrender itself to, and become absorbed in, them in order thoroughly to understand its incredibly profound and intimate language. Instead of this, the mind during highly complicated opera music is at the same time acted on through the eye by the means of the most variegated display and magnificence, the most fantastic pictures and images, and the most vivid impressions of light and color; moreover, it is occupied with the plot of the piece. Through all this it is diverted, distracted and deadened, and thus rendered as little susceptible as possible to the sacred, mysterious and profound language of tones.” Schopenhauer, *Parerga and Paralipomena* (1851), vol. 2, trans. E. F. J. Payne (Oxford: Clarendon Press, 1974), p. 432.

247. See the historical account of the behavior of French operatic audiences in the nineteenth century in James H. Johnson, *Listening in Paris: A Cultural History* (Berkeley: University of California Press, 1995). Johnson details the many factors that gradually led to an etiquette of relative silence in the opera house, to “ever more restrained and outwardly attentive audiences,” to the idea of “an attentive, absorbed public,” which would have been unthinkable in the eighteenth century. See also the broader discussion of the remaking of spectator conduct during the nineteenth century in Richard Sennett, *The Fall of Public Man: On the Social Psychology of Capitalism* (New York: Random House, 1978), pp. 205–218.

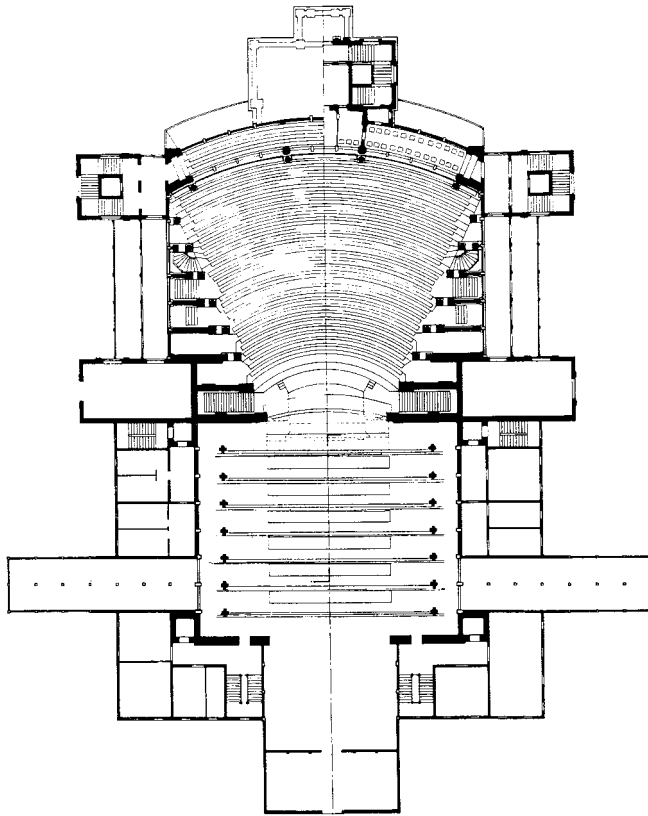

*Ground plan of
Festspielhaus at
Bayreuth, 1876.*

attentiveness of an audience, to subordinate it to the will of the artist and to generate a collective state of reception worthy of an art with such social aspirations.²⁴⁸

One of Wagner's "reforms," incarnated in the design of Bayreuth, involved the transformation of the nineteenth-century theater into a construction of visibility that more rigorously structured the spectator's perceptual experience. His aim was

248. Max Nordau, for whom Wagner was the foremost incarnation of degeneracy, denounced the composer for his subversion of traditional notions of attentiveness. He complains that Wagner's "unending melody" is a "product of degenerate thought; it is musical mysticism. It is the form in which incapacity for attention shows itself in music. In painting, attention leads to composition; the absence of it to a uniformly photographic treatment of the whole field of vision as with the Pre-Raphaelites. . . . In music, attention expresses itself in completed forms, i.e. in well-defined melodies; its absence, on the contrary, shows itself by the dissolution of form, the obliteration of its boundary lines, and thus by unending melodies as with Wagner." Nordau, *Degeneration*, p. 199. See also Nietzsche's association of decadence and "the deterioration of the melodic," in *Selected Letters of Friedrich Nietzsche*, ed. Christopher Middleton (Chicago: University of Chicago Press, 1969), p. 233.

to establish a “theatron,” a “place for seeing,” and it was through the collective act of seeing that the semblance of a community would come into being.²⁴⁹ First Wagner completely eliminated the lateral views of older theater design to achieve a frontal engagement with the stage for every spectator. He also initiated the idea of near-complete darkness as a way of heightening the intensity of lighting effects on stage and preventing peripheral distraction. The multiplication of proscenium arches combined with the extreme darkness of the theater was intended to detach the illuminated stage from any legible relation to the rest of the opera house. Wagner’s insistence on lowering the orchestra out of sight is another part of the phantasmagoric character of his work, discussed by Theodor Adorno and others, where “phantasmagoric” designates the systematic concealing and mystification of the processes of production. By making the orchestra invisible, Wagner made the source of the music unidentifiable and hence mystified.²⁵⁰

It is important not to completely separate these elements of Wagner’s illusion-making from a larger nineteenth-century history of visual display. For example, the lantern projections for the first performances of *Das Rheingold* in 1876 come out of a long tradition of magical and popular entertainment that had been widespread for decades. Wagner disdainfully looked on the diorama and panorama as the mass forms of verisimilitude he sought to avoid in his productions, but these were the kind of popular attractions with which he would have felt himself in competition. For the diorama, at its peak of popularity in the late 1830s and early 1840s, operates according to principles not unrelated to the effects produced subsequently at Bayreuth. In particular, the experience of the diorama (coming as it did out of Daguerre’s successful work as a theatrical designer) was based on a

249. In Wagner’s own words, the primary illusion at Bayreuth “is created by the fact that the spectators think that what is happening on the stage is far away, while they perceive it with all the clarity of actual proximity; this gives rise to a further illusion, namely that the people appearing on stage are of superhuman stature. The success of this arrangement alone should be enough to give some idea of the incomparable effect of the relationship thus created between spectator and stage. As soon as the spectators are sitting in their seats, they find themselves in a virtual ‘theatron,’ that is, a space designed solely for looking at what can be seen from its seats. Between the spectators and the scene to be observed nothing is clearly visible; there is only a ‘space,’ kept indeterminate by architectural mediation, between the two prosceniums, presenting the distanced image in all the inaccessibility of a dream vision.” Wagner, *Gesammelte Schriften und Briefe*, ed. Julius Kapp, vol. 12 (Leipzig: Hesse und Becker, 1914), p. 291, cited in Schivelbusch, *Disenchanted Night*, p. 219. In this text Schivelbusch discusses the similarities between effects produced at Bayreuth and Daguerre’s diorama from the 1820s.

250. The details of Wagner’s practical remaking of theatrical experience are available in many places. One valuable account, because of its focus on the continuity of Wagner’s work with cinema, is Jo Leslie Collier, *From Wagner to Murnau: The Transposition from Stage to Screen* (Ann Arbor: UMI Research Press, 1988), pp. 9–34. Adorno’s chapter on “Phantasmagoria” in his *In Search of Wagner* remains essential; see also note 270 below.

similar disruption of an intelligible relation of distance between viewer and illusory scene. Numerous firsthand accounts stressed the visual disorientation that confounded conventional pictorial cues about the relative proximity of near and far objects. The diorama also commanded visual attention through the disjunction between its illuminated imagery and the darkened space of the spectator. Despite his archaizing surfaces, Wagner stands for a will to mastery over all aspects of spectacle that would allow for the calculated production of states of regression, fascination, dream—the very attentiveness that would belong to cinema half a century later, with the introduction of synchronized sound. Nonetheless, Wagner's control over emotional response was effective enough to provoke Nietzsche's remark that Wagner furnished "the first example, only too insidious, only too successful, of hypnotism by means of music . . . persuasion by the nerves."²⁵¹ According to Nietzsche, it was a specifically modern "counterfeiting of transcendence."²⁵²

Soon after the first performances at Bayreuth, Wagner's concrete remaking of the spectator's experience was noted by French critics.²⁵³ Eugene Veron in 1878 wrote that Wagner disposed everything "in such a way that the spectator would be exclusively preoccupied with the spectacle and could not be distracted by foreign impressions . . . and nothing could divert their attention from the point on which it should be concentrated." It was, he maintained, the production of a dreamlike clairvoyance, unlike normal waking states.²⁵⁴ A decade later such assessments of

251. Nietzsche, *The Case of Wagner*, p. 171.

252. *Ibid.*, p. 183.

253. On Wagnerism in France, see the invaluable *Wagner et la France*, ed. Martine Kahane and Nicole Wild (Paris: Editions Herscher, 1983). See also Isabelle Wyzewska, *La Revue wagnerienne: Essai sur l'interprétation esthétique de Wagner en France* (Paris: Librairie Académique Perrin, 1934); Gerald D. Turbow, "Art and Politics: Wagnerism in France," in David C. Large and William Weber, eds., *Wagnerism in European Culture and Politics* (Ithaca: Cornell University Press, 1984), pp. 134–166; Christian Goubault, "Modernisme et décadence: Wagner et anti-Wagner à la musique française de fin de siècle," *Revue internationale de musique française* 18 (November 1985), pp. 29–46; Richard Sieburth, "1885, February: The Music of the Future," in Denis Hollier, ed., *A New History of French Literature* (Cambridge: Harvard University Press, 1989), pp. 789–797; Erwin Koppen, "Wagnerism as Concept and Phenomenon," in Ulrich Müller and Peter Wapnewski, eds., *Wagner Handbook* (Cambridge: Harvard University Press, 1992), pp. 343–353; L. J. Rather, *Reading Wagner: A Study in the History of Ideas* (Baton Rouge: Louisiana State University Press, 1990), pp. 59–77; and Elaine Brody, *Paris: The Musical Kaleidoscope, 1870–1925* (New York: Braziller, 1987), pp. 21–59. An entertaining account of the *Revue wagnerienne* is presented in Jacques Barzun, *Darwin, Marx and Wagner: Critique of a Heritage*, 2d ed. (New York: Doubleday, 1958), pp. 288–293. Also important is the discussion of Wagner in Jane Fulcher, *The Nation's Image: French Grand Opera as Politics and Politicized Art* (Cambridge: Cambridge University Press, 1988), including her reading of a Wagnerian subtext in Manet's 1862 painting *Music in the Tuileries*.

254. Veron, *L'esthétique*, p. 395.

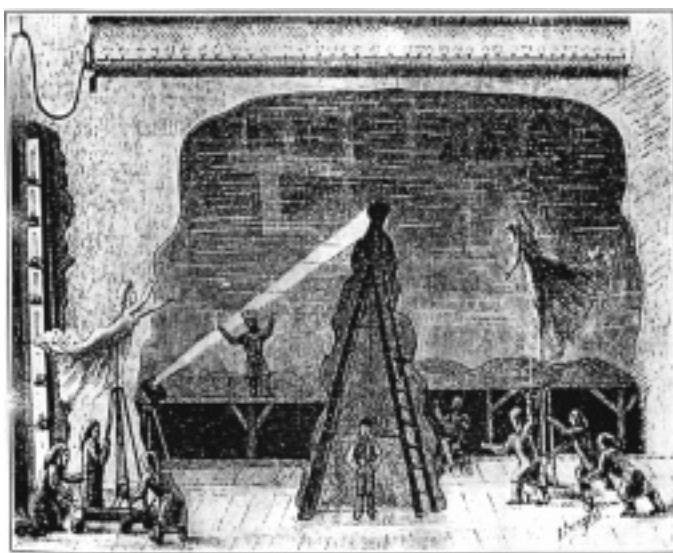

Rhinemaidens in Wagner's Das Rheingold: as seen by the Bayreuth audience and from backstage, late 1870s.

Wagner's attentional strategies were pervasive. In the March 1887 issue of the *Revue wagnérienne* a laudatory article by Charles and Pierre Bonnier astutely described Wagner's measures at Bayreuth for controlling attention and for provoking "the fullest possible perception." Notably, they insisted that the visual effects were more significant than acoustical ones.²⁵⁵ According to these writers, the basis of Wagner's "optics" begins with "doing away with the autonomy of the audience" by "absorbing and dominating it." They detail an approach that certainly confirms Nietzsche's reading of Wagner as a "master of hypnotic tricks": a means of "isolating attention and fixing the gaze" in order to impose the theatrical illusion more fully and intensify the effects of the music. Wagner's effects are in part achieved through a process of optical disorientation that disrupts conventional theatrical

255. Charles and Pierre Bonnier, "Documents et critique expérimentale: Parsifal," *Revue wagnérienne* 2 (March 1887), pp. 42–55. A year earlier, a related assessment was made in terms of the specific expectations of French audiences: "At Bayreuth, for the spectator plunged in darkness, all effects have a redoubled intensity, effects of daylight more brilliant, of night even blacker, and electric light more supernatural. If for us French, the theater is a place of pleasure, where everything is a distraction, where the gratification of seeing the opera is no greater than the pleasure of being seen oneself, this German system will seem shocking to us at first." Albert Soubies and Charles Malherbes, *L'oeuvre dramatique de Richard Wagner* (Paris: Fischbacher, 1886), p. 290.

space. Detailing the well-known features that produced Wagner's "mystic abyss"—the multiplication of proscenium arches, the convex curvature of the "roof" concealing the orchestra, and the darkness of the theater—the Bonniers describe a breakdown of standard perspectival expectations so that there is no rationalizable or metric relation between the position of a spectator and the events on stage. It is a calculated confusing of the distance separating the viewer from the spectacle, with the result of making figures seem larger than life and producing other distortions of scale.²⁵⁶ This dissociation between stage and audience is further enhanced by the extreme contrast between the brightness of the stage and the darkness of the rest of the theater, which make the stage seem like "a luminous detached rectangle." This isolated zone of brightness, they insist, produces a *fixation* of the eyes on the same points throughout, and the gaze of the viewer can be "easily dominated." The overall organization of this "theatrical apparatus," they conclude, "compels attention and controls sensorial perception."

A few years later, the art theorist Paul Souriau noted the "absolute illusion" produced by the invisibility of the orchestra at Bayreuth, and noted that the inability to localize the origin of musical sounds enhanced their magical and hypnotic effects.²⁵⁷ Souriau was one of the first critics to characterize Wagner's work specifically as "phantasmagoric," as situated in a lineage not only of opera and musical practice but also of illusion and suggestion, beginning with late eighteenth-century phantasmagoric displays and spectacles. At the same time, writing near the threshold of cinema's emergence, he foresees how the effects of Wagner's work have unrealized possibilities of technological expression:

The phantasmagoria ought to take its place in the rank of the arts, as one of the most suggestive of the arts. How often in listening to music we have images before our eyes as objects of contemplation, but they are light, mobile, almost immaterial images, having only a shadow of reality, as if they are the luminous projection of our reveries produced by the music. Perhaps a new Wagner will soon write an opera for the magic lantern—an opera of dreamlike music and fantastic and virtually imaginary tableaux.²⁵⁸

256. Nietzsche seems to have understood this Wagnerian illusion of increased size: "Ah, this old magician. How much he has imposed on us. The first thing his art offers us is a magnifying glass: one looks through it, one does not trust one's eyes, everything looks big." *The Case of Wagner*, p. 160.

257. Paul Souriau, *La suggestion dans l'art* (Paris: Felix Alcan, 1893), pp. 176–177.

258. *Ibid.*, p. 59.

Finally this leads us back to Seurat, who was well aware of this dimension of Wagner's practice, either through articles such as this one or from his friends who had been to Bayreuth.²⁵⁹ But what is most extraordinary is that Seurat, knowing of these explicitly theatrical effects, sought to emulate them in a radically different medium, by producing a related impression with the painted framing on the borders of his large canvases. His friend Emile Verhaeren wrote: "Seurat reflected on how at Bayreuth the theater was completely darkened before presenting the stage bathed in light as the solitary center of attention. The idea of this kind of stark contrast between brightness and darkness led him to adopt more somber frames, even while maintaining his practice of doing them in complementaries."²⁶⁰ This confirms not only that Seurat thought in terms of managing attention but that he was able to find models for his own practice in cultural arenas other than the visual arts, specifically in the visual and theatrical dimensions of Wagner's operas. And it is evidence of the weight of Wagner's reputation during these years that even indirect verbal accounts of the experience of Bayreuth could have had such an effect.²⁶¹

Seurat's relation to Wagner, like that of Mallarmé, was profoundly mixed. (Mallarmé also had little firsthand experience of Wagner's work yet produced one of the most important critical responses to it). While Seurat was clearly interested in many possible techniques of controlling and managing subjective response, his last major paintings are decisive subversions of the representational pretenses of any forms of verisimilitude, whether of Salon painting, photography, panoramas, or any phantasmagoric production. Seurat's work renders evident the constructed and artificial nature (on several levels) of illusion, making it part of the work itself—in a sense an anti-phantasmagoria. If there is a latent critique of Wagnerism

259. Descriptions, illustrations, and photographs of Bayreuth were widely available in France throughout the 1880s. See for the example the images of the Festspielhaus interior accompanying Adolphe Jullien, "Les Maitres Chanteurs de Nuremberg de Richard Wagner," *L'Art* 45 (1888), pp. 153–160.

260. Emile Verhaeren, "Georges Seurat," *La société nouvelle*, April 30, 1891, 429–438; reprinted in *Seurat: Correspondances, témoignages, notes inédites, critiques*, ed. Helene Seyres (Paris: Editions Acropole, 1991), 272–282. For a brief but provocative discussion of the relation between Seurat and music, see Lebensztein, *Chabut*, pp. 67–76.

261. The issue here clearly touches on the construction of a mythology of Bayreuth by converted enthusiasts. Seurat and others might well have been stunningly disappointed to see the actual stagecraft. For the early performances of the *Ring* "there had been so much talk beforehand about technological wonders that a let-down was inevitable. It was all the greater because the novel stage effects were what most often failed. The magic fire—gas jets in fact—seemed neither magic nor fire. The rainbow bridge put Hanslick in mind of a 'seven colored sausage.' The *Ring* zoo, especially the dragon, aroused embarrassment. The magic lantern slides portraying the ride of the Valkyries could be deciphered only by those close to the stage." Frederic Spotts, *Bayreuth: A History of the Wagner Festival* (New Haven: Yale University Press, 1994), p. 74.



Cartoon titled "The Modern Knights of the Grail," showing Liszt, Wagner, and von Bulow, 1882. Reprinted in Jullien, *Richard Wagner: Sa vie et ses oeuvres*, 1886.

in *Parade de cirque*, it is not that the painting is a counterimage of a popular, low-life urban street entertainment thrown up against the reverential pretensions of his Wagnerian friends. Even the most class-conscious commentators have seen little in it that is celebratory of urban street culture. Rather, *Parade de cirque* can be read as a ruthless dismantling of the Wagnerian model of spectacle, a bitter parody and unmasking of its attempt, incarnated in the central figure, to combine myth and music as social rite, and to valorize the artwork as a figuration of a unified community in the making. The trombone, in the popular press, had been singled out as a visual element of Wagnerian performance that was useful for comic caricature.²⁶² Certainly Seurat's keen visual wit would have registered the identity between the figure zero and the form of a ring. If the literal ring in Wagner's tetralogy was the vehicle of decadence and an annihilating cash nexus, the total *Ring* cycle was the last expression of a nineteenth-century fantasy of the recuperation of tragedy and myth, of the dream that culture could make whole what capitalism had broken apart. As Philippe Lacoue-Labarthe has remarked, the fantasy encompasses

262. For example, a cartoon, reproduced in Adolphe Jullien's popular monograph *Richard Wagner: Sa vie et ses oeuvres* (Paris: J. Rouam, 1886) showed two leading Wagnerians, Franz Liszt and Hans von Bulow, holding trombones while flanking their master, beneath the "grail" of a beer stein. In recent music historiography, it has been noted that "the sound of trombones in Wagner calls to mind such heroic unison tunes as the Act III Prelude in *Lobengrin* or the Ride of the Valkyries." Jonathan Burton, "Orchestration," in Barry Millington, ed., *The Wagner Compendium* (New York: Schirmer, 1992), p. 344.

the disturbing conviction “that, in an age where transcendence fails and is undone, the vocation of art can still be to recover an ancient destination and establish the type; or, if one prefers, the mythological figure, where humanity (a people, for example), could recognize itself.”²⁶³ Seurat, despite his fascination with the phenomenon of Wagner and the revalorization of theater, exposes the spuriousness and desiccation of this dream, as the banality of his “Panathenaic procession” in *La Grande Jatte* makes clear. But his resistance to Wagner’s images should not be thought of in terms of a counteradvocacy of representations of concrete social and historical reality. As Michel Foucault has insisted, writing about the late 1970s Boulez/Chareau production of the *Ring*, “The nineteenth century was full of images which were the true reason for Wagner’s great mythological reconstructions, which they changed and concealed . . . that nineteenth century world of images which Bakunin probably shared with Marx, Dickens, Jules Verne, Bocklin, the architects of bourgeois factories and villas, with the illustrators of children’s books and the agents of anti-Semitism.”²⁶⁴ Seurat’s paintings must also be seen as part of this eclectic composite imaginary of the nineteenth century.



I want to pursue these issues of the crowd, theater, and phantasmagoria along a parallel historical track. *Parade de cirque* has often been discussed in relation to another work—Seurat’s last major painting (which at his death remained unfinished), *Cirque* of 1890–1891. In certain ways *Cirque* can be read as a pendant to the earlier work—on one level, it reveals to us what is completely excluded in *Parade de cirque*. That is, it shows the interior spectacle to which people, like those observers in the earlier work, have paid admission and now sit as spectators. If *Parade de cirque* was, as I’ve tried to suggest, a disclosure of the absence at the heart of modern spectacle and perception, *Cirque* might seem to be a replenishing of the void in the earlier work, a vivid opening onto a light-filled, action-filled arena. The motionless and nocturnal world of the space-drained *Parade de cirque* apparently gives way to a concrete vision of the attractions (and the entertainment commodity) that it had evoked but withheld. The relation between the two paintings can also be articulated in terms of two fundamentally different organizations of theatrical space: the classical or Italianate “scenography” that is implicit in *Parade de cirque* (even as Seurat dismantles it), which I have shown above, and the much older historical form of the circus or arena. But in spite of these distinctions

263. Philippe Lacoue-Labarthe, *Musica Ficta: Figures of Wagner*, trans. Felicia McCarren (Stanford: Stanford University Press, 1994), p. 59.

264. Michel Foucault, “Nineteenth Century Imaginations,” *Semiotexte* 4, no. 2 (1982), pp. 182–190.

and apparent oppositions, both paintings are dissolutions of these older scenes of representation. The importance of *Cirque* has less to do with the contemporary actuality of any circus show and audience in 1890 and more to do with an investigation of the *conditions* under which a subject could be activated as an attentive perceiver.

If Verhaeren's remarks about Seurat's secondhand knowledge of Bayreuth are accurate, we see perhaps the most obvious (and literal) attempt to put them into practice here: the use of darker and wider frames to accentuate the brightness of his image.²⁶⁵ Gustave Kahn, based on conversations with the artist, says Seurat took from Wagner a conception of the frame as "an isolating agent."²⁶⁶ This particular conceptualizing of the frame is another explicit renunciation of both the classical and even early modernist status of the image—it is posed neither as a windowlike plane intersecting a cone of vision nor as a flat plane covered with colored patches. Seurat attempts, as he believed Wagner had done, to make an autonomous and luminous field of attraction, with a deliberately ambiguous spatial identity. So much of Seurat's preoccupation with color is both an obsession with light and with techniques to master it. We know well that he believed his deployment of optical mixture (that is, of separate pure colors combined on the retina) would produce luminous effects more intense than anything possible by traditional pigment mixture.²⁶⁷ In a very general sense, then, we can link this feature of Seurat's work with other optical experiences in the nineteenth century that severed the image from any continuous or intelligible relation to the position of the observing subject, such as the diorama or the stereoscope. There are many places in the late nineteenth century where an image's apparitional value is an effect of its detachment from or cancellation of a broader visual field. But clearly the content of this painting too, like that of *Parade de cirque*, seems willfully re-

265. Verhaeren also expressed his own skepticism about Seurat's use of framing to set off his work. Seurat's mistake, he writes, lies in not realizing "that in the theater the contrast is continued and extends itself to meet the eye of the spectator, while on the wall of a room or gallery, it has, so to speak, no space, the frame being narrow and bordering the picture the way a binding or hem borders a piece of drapery." Verhaeren, "Georges Seurat," reprinted in Broude, ed., *Seurat in Perspective*, p. 28.

266. Gustave Kahn, "Seurat," *L'Art moderne* 11 (April 5, 1891), pp. 107–110; reprinted in Broude, ed., *Seurat in Perspective*, p. 22. See the valuable discussion of the larger issue of the painted frame in neoimpressionist practice during the late 1880s and early 1890s, in Ward, *Pissarro, Neo-Impressionism, and the Spaces of the Avant-Garde*, pp. 118–122. Ward is one of the very few art historians to recognize the centrality of attention as a problem for Seurat and, subsequently, for others in his circle.

267. Seurat's follower Paul Signac declared that "the separation of elements and optical mixtures produces purity, that is to say, luminosity and intensity of tones," in his *D'Eugene Delacroix, au neo-impresionisme* (1899; Paris: Hermann, 1978), p. 119. See also the account in Felix Feneon, "Neo-Impressionism" (1887), in Linda Nochlin, ed., *Impressionism and Post-Impressionism, 1874–1904* (Englewood Cliffs, N.J.: Prentice-Hall, 1966), pp. 110–112.

mote from ambitions related to a Wagnerian aesthetic. I am suggesting that Seurat's interest in the "Bayreuth effect" is more usefully understood in terms of his proximity to another collective visual experience—precinematic forms of moving images, projection, and animation.

Within the dense and contentious space of cinematic prehistory, one well-known but marginalized figure is Emile Reynaud, who worked continuously from the mid-1870s to the mid-1890s on various devices for the simulation of movement.²⁶⁸ In many reductive histories of cinematic technology, Reynaud is positioned as a technical contributor: he is credited with developing the use of a continuous, flexible translucent band or strip on which individual images could lie in sequence, a band that he then regularly perforated with a single hole to facilitate its controlled passage through a projection device. His deployment of celluloid was, in conventional histories, simply one of the ingredients that would coalesce into a more fully articulated cinematic apparatus by the mid-1890s. Perhaps more significantly, Reynaud's commercial "screenings," if we can use this anachronism, at the Musée Grévin in Paris beginning in 1892 are generally considered to be the first public experience of projected moving images from film (what were effectively animated cartoons). What Reynaud did *not* do up to that point was to pursue any strategies for working with *photographic* images, for almost all of his productions involved his own hand-made drawings. Thus while he grasped something essential about the mechanical arrangements necessary to animate still images, he is also seen as a figure still trapped in older artisanal modes of production, committed to what frankly were inefficient means of making his brief film strips—spending months making hundreds of drawings on the strip itself, and hand-coloring them, for a display that would last only a few minutes. During the most productive years of his career, he never showed any interest in working with images mechanically produced by a photographic camera.²⁶⁹

268. On Reynaud, see the invaluable monograph by Dominique Auzel, *Emile Reynaud et l'image s'anima* (Paris: Du May, 1992). See also *Emile Reynaud, peintre de films* (Paris: Cinematheque française, 1945; rpt. Paris: Editions Maeght, 1992); Laurent Mannoni, *Le grand art de la lumière et de l'ombre* (Paris: Nathan, 1995), pp. 339–358; Georges Sadoul, *L'histoire generale du cinema*, vol. 1 (Paris: Editions Denoel, 1948), pp. 111–128, 237–250; Leo Sauvage, *L'affaire Lumiere: Enquete sur les origines du cinema* (Paris: Lherminier, 1985), pp. 49–72; Gilles Ciment, "Dessins inanimés, avez-vous donc une âme?," *Positif* 388 (June 1993), pp. 48–49; and Vanessa Schwartz and Jean-Jacques Meusy, "Le Musée Grévin et la cinématographe: l'histoire d'une rencontre," *1895*, no. 11 (December 1991), pp. 19–48. Reynaud's idiosyncratic importance is also discussed in François Dagognet, *Philosophie de l'image* (Paris: J. Vrin, 1986), pp. 56–57.

269. See, for example, the account in Alan Williams, *Republic of Images: A History of French Filmmaking* (Cambridge: Harvard University Press, 1992), pp. 15–16, which sets up Reynaud as a provincial bricoleur: "But compared with the true camera, the spectacle at the Musée Grévin was *incompletely mechanized*. Reynaud gave performances rather than mere projections." (Emphasis in original.)

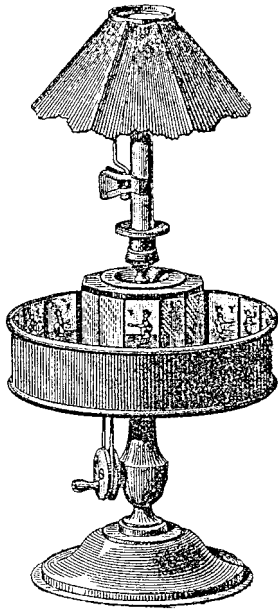

Emile Reynaud, Praxinoscope, 1876.

But this is hardly a fair or useful account of Reynaud, and it will ultimately be more interesting to consider why he seems to have willfully distanced himself from the crucial mimetic component of the cinematograph to come. To begin with, Reynaud's career has certain loose similarities to Edison's. Both were hands-on inventors who continually assessed the relationship between their own technological products and the makeup of their audience and the economic realities of the marketplace. Reynaud's output bespeaks a continuing effort to update, to modify his machines both in terms of performance and of shifting audience needs and possibilities. Even if he concretized it only in a modest way, Reynaud grasped, as did Edison, the relationship between hardware and software and only produced viewing and projection devices for which he would supply the visual "software." In this respect, even if there was an artisanal aspect to the fabrication of his film strips, he was a media entrepreneur far ahead of many of his contemporaries in his immersion in the logic of modernization (although he finally came up short in the late 1890s when his attempts to develop a marketable stereo-cinema proved unsuccessful.) From his early Praxinoscope, which sold over 100,000 models between 1876 and 1877, to the Théâtre-Optique in the 1890s, which drew over half a million spectators during the eight years of its public existence, Reynaud produced objects that can hardly be called marginal.

The Praxinoscope was a variation on the idea of the zoetrope, an optical device for the simulation of movement which was first built in the late 1830s. Reynaud's essential modification consisted in constructing an open rotatable drum with a central cylinder around which mirrors were positioned. Along the inside of the drum long flexible bands of sequential images could be easily inserted and removed, so that what an immobile spectator saw were the *reflected* images of the insertable band. Also Reynaud built into each Praxinoscope a light source that directly illuminated the interior of the drum. (I say "he built," but it should be emphasized that Reynaud's devices were industrially manufactured based on prototypes of his design, and were marketed in department stores). The point I want to emphasize is that, in using a lamp and reflective surfaces, one of Reynaud's goals was to have an image of greater luminosity than had been possible with the simple zoetrope or related machines.

But with his initial Praxinoscope model, the impact of this moving image, luminous and in color, was dissipated by the fact that a spectator could see more than one reflected image and the actual images on the inner wall of the drum all at the same time, for the machine was designed to allow several spectators to watch simultaneously. By exposing its inner workings, the device divided the observer's attention, so that one could become as entranced by the overall flickering and movement of the machine as by the appearance of a single figurative image. So by 1879 Reynaud made a superstructural change that left the mechanical operation of the Praxinoscope untouched in terms of the actual production of illusory movement, but dramatically transformed the experience of the spectator. He designed what was patented and sold as the Praxinoscope-Theatre.

This device of 1879 does not expose its technical operation: the new design allows the spectator to shut out the constructed nature of its illusion. That is, Reynaud moved to an apparatus that was fundamentally "phantasmagoric" in Adorno's sense: "the occultation of production by means of the outward appearance of the product."²⁷⁰ Reynaud's Praxinoscope-Theatre provided an architectural framing of the spinning mirrored drum that created an experience for a solitary and immobile spectator. The animated figures are now seen not only through a

270. Adorno, *In Search of Wagner*, p. 90. Phantasmagoria is "the point at which aesthetic appearance becomes a function of the character of the commodity. As a commodity it purveys illusions. The absolute reality of the unreal is nothing but the reality of a phenomenon that not only strives unceasingly to spirit away its own origins in human labor, but also, inseparably from this process and in thrall to exchange value, assiduously emphasizes its use value, stressing that this is its authentic reality, that it is 'no imitation'."

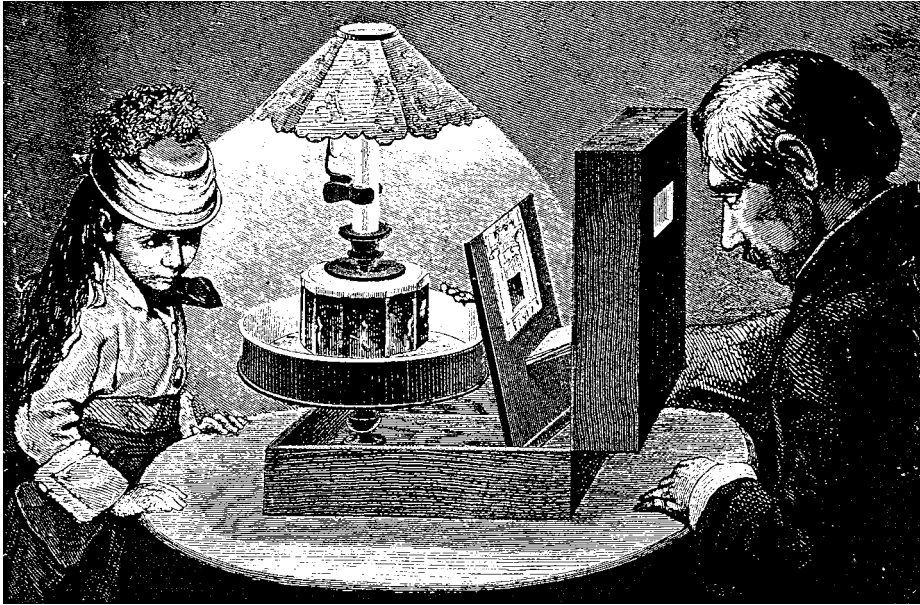

Emile Reynaud, Praxinoscope-Théâtre, 1879.

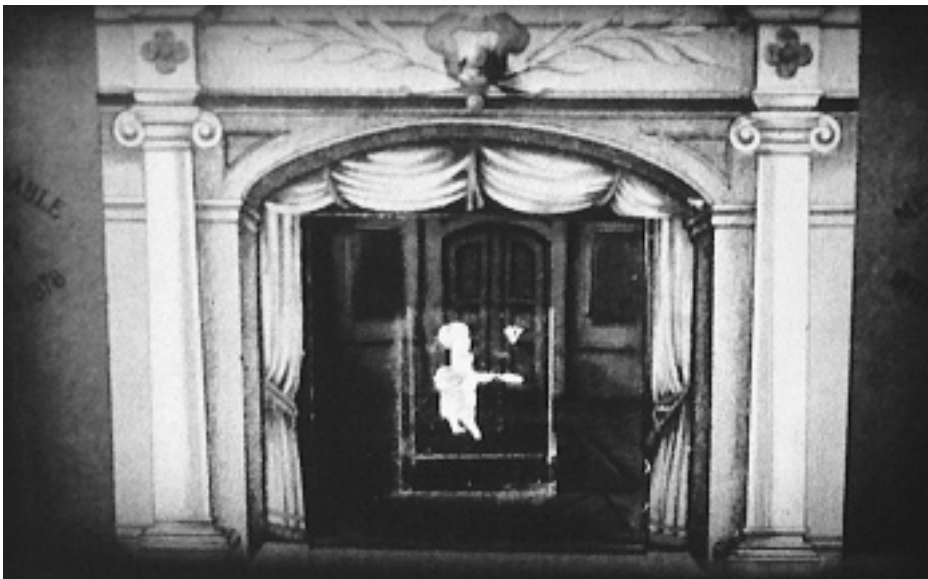

View of Praxinoscope-Théâtre in operation.

PRAXINOSCOPE-THÉÂTRE

MÉD. DE BRONZE EXP^o UNIV^o 1889



20 sujets parus (sur fonds noirs)

20 sujets parus (sur fonds noirs)

ER
PARIS

Le Praxinoscope-Théâtre, par une disposition très-simple, produit de curieuses scènes animées, où l'illusion du relief et l'attrait du décor viennent s'ajouter à l'illusion du mouvement.

Advertisement for Praxinoscope-Théâtre, c. 1880.

proscenium arch but seemingly “in front of” various scenes, six of which came with the device and could be changed at will, as could the bands of animated figures. The consumer, with this handful of software items, could produce a combination of various “theatrical” events. Most important, and difficult to convey in the absence of the actual machine, is the unusual quality of the image. Figures moving with the familiar elemental rhythms of the phenakistoscope or zoetrope now had an unsettling actuality as well. Previously detached and ungrounded, they become an active part of an illusory spatial arrangement. The synthesis of moving figure and stagelike background produces an effect that seems three-dimensional, but it is rather a sense of spatial dislocation that results from the overlapping of disparate two-dimensional systems. The image of the animated figure amid the scenic decor (whether blowing bubbles, tossing feed to chickens, jumping rope, juggling, sawing wood) is effectively a spectral atopic image (it literally is not there) and is seemingly present only through an optics of reflection, like earlier nineteenth-century magic displays such as some of the phantasmagorias

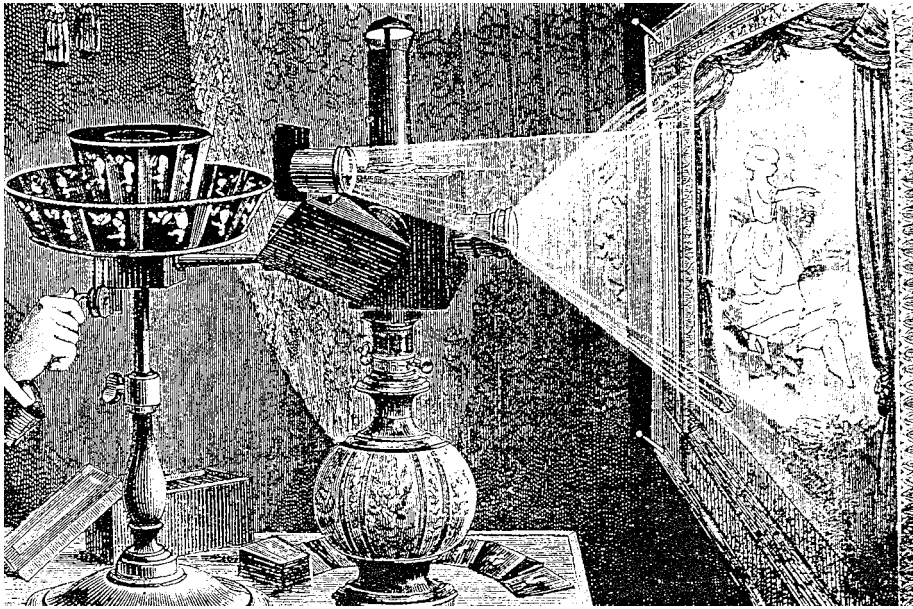

Emile Reynaud, Praxinoscope à Projection, 1882.

and the so-called Pepper's Ghost illusion. The disjunction between the two components of the theater image is further heightened by the greater luminosity of the reflected image, giving it a shimmering detachment from its surroundings. Around 1882 Reynaud began marketing a related device called the Praxinoscope à Projection, which allowed a group audience to see, now projected onto a wall or screen, the same synthesis of two images, one that projected the static backdrop and the other that projected the animated figure. Reynaud's system of perpetual technological modernization continued unabated, and by the next year he patented a projection apparatus which, although it superseded his Lilliputian theater, retained some of the essential features of the device we have just examined.

The basic optical system that Reynaud worked with from 1879 into the late 1890s was thus based on a composite and disjunct character of the illusory image. His most successful project, the Theatre-Optique, relies likewise on two simultaneous projections. One is a relatively conventional lantern projector which throws a static image of a scenic background onto the screen. At the same time Reynaud's much more intricately devised reflective apparatus, with its moving band of film, projects the animated figures onto the appropriate area of the first projection. The

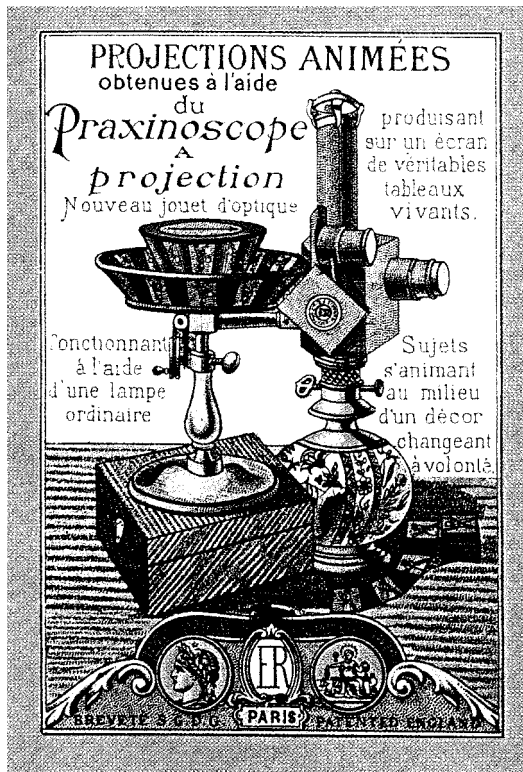

Advertisement for *Praxinoscope à Projection*, c. 1882.

visual experience of the Théâtre-Optique became, in important ways, a full-scale version of the little Praxinoscope-Theatre. Beginning in 1892, spectators of the Théâtre-Optique sat in the darkened auditorium of the Musée Grévin and saw the animated figures move in the same way, as had those of the earlier “theater,” both within and strangely dissociated from a scenic background.²⁷¹ The overriding impression is of figures that are moving but *ungrounded*.

It is easy to understand how traditional film history, obsessed as it was for so long by a photographically determined idea of the reality effect, would have relegated Reynaud’s work to a marginal and “primitive” line of experimentation

271. On the rich history of the Musée Grévin, see Vanessa Schwartz, *Spectacular Realities: Early Mass Culture in Fin-de-Siècle Paris* (Berkeley: University of California Press, 1998), pp. 89–148. In this valuable study, Schwartz locates Reynaud’s work within “a visual culture that included such phenomena as the mass press, the morgue, panoramas, dioramas and wax museums,” and she argues that cinema must be understood as a product of this complex social milieu.

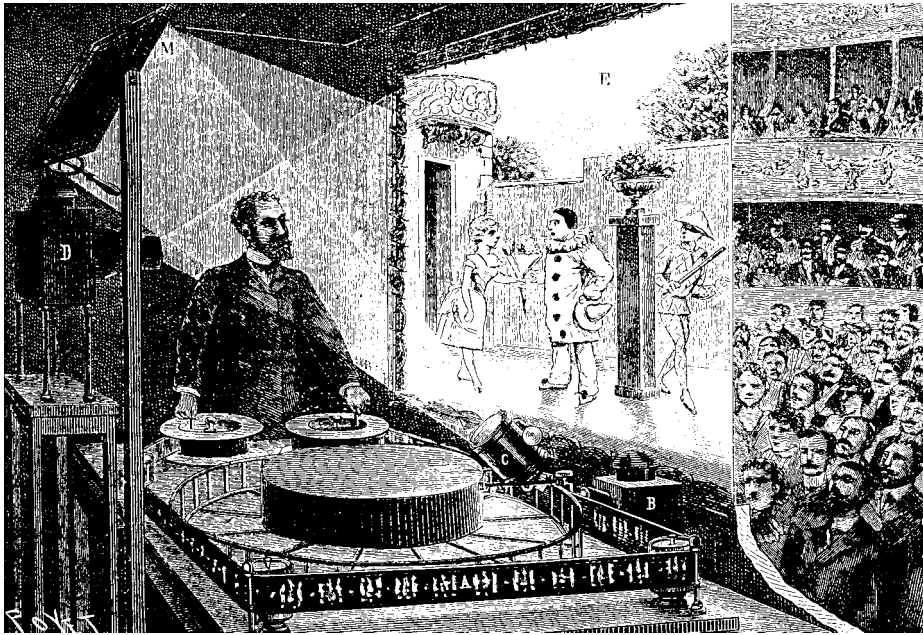

Emile Reynaud, Théâtre-Optique, 1892.

doomed to irrelevance and extinction, with even some of his defenders sharing such an assessment.²⁷² But during the 1890s, for at least five years after the theatrical appearance of Lumiere's Cinématographe and other related entertainments, Reynaud's *Pantomimes Lumineuses* drew well over a thousand paying customers each week. One conclusion is obvious: contemporary audiences, most of whom would also have been familiar with Lumiere's films, did not regard Reynaud's hand-made cartoonlike shorts as an inadequate or incomplete form of cinema but as attractions in their own right with their own particular pleasures, which must not be judged in relation to what were to prove more pervasive and historically durable modes of representation.

When Reynaud signed a contract with the Musée Grévin in October of 1892 for the screening of his *Théâtre-Optique*, he had already been at work since late 1888 manufacturing the much longer bands of film that were eventually to be pub-

272. Reynaud has often been positioned as a precursor of twentieth-century avant-garde filmmakers who also worked directly on the strip of film, painting, drawing, or scratching on it, such as Oskar Fischinger, Norman MacClaren, and Len Lye.

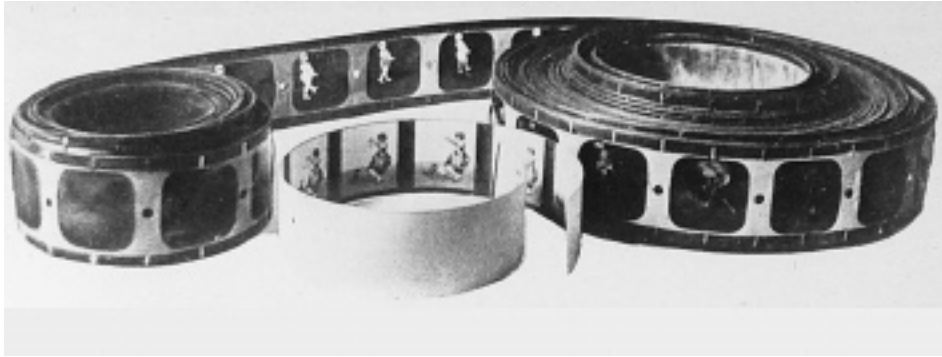

Emile Reynaud, band for use in Théâtre-Optique; in foreground, smaller band for Praxinoscope.

licly exhibited at this venue. He worked for over three years hand-making three short films, which ranged from about seven to fourteen minutes in length. The bands that he had used in the praxinoscope models had twelve or so images on them, while these new works had as many as seven hundred different hand-drawn and hand-colored images. Hence the persistent characterization of Reynaud's work as an aberrant artisanal hybrid, outside of the conditions of an era of mechanical reproduction. But it is important to remember that Reynaud's work, especially these longer films, were extended analyses and decompositions of movement. As early as 1877 he had used some of Muybridge's studies for his praxinoscope bands and clearly had been aware of Marey's work since the early 1880s. By the late 1880s and early 1890s his analysis of movement reached unprecedented levels of abstraction in his use of drawings of the same positions to simulate both forward and reverse motion. In effect he intuited how to dissociate motion from time by redundantly combining forward and reverse movement into what we would now call loops, as well as using varying speeds and, even in his performances, stopping the projection on a single image. In one of the first public displays of projected moving images, spectators encountered elastic and reversible temporalities that had little to do with the notion of "real time" that was supposedly central to the inaugural cinema of the Lumières in the mid-1890s.

Now we can return to Seurat's *Cirque*, which he began in late 1890 and worked on in the first months of 1891. For decades this image has been discussed in terms of Seurat's relation to popular culture, both as the representation of an actual circus performance and as a reworking of certain pictorial ideas from the

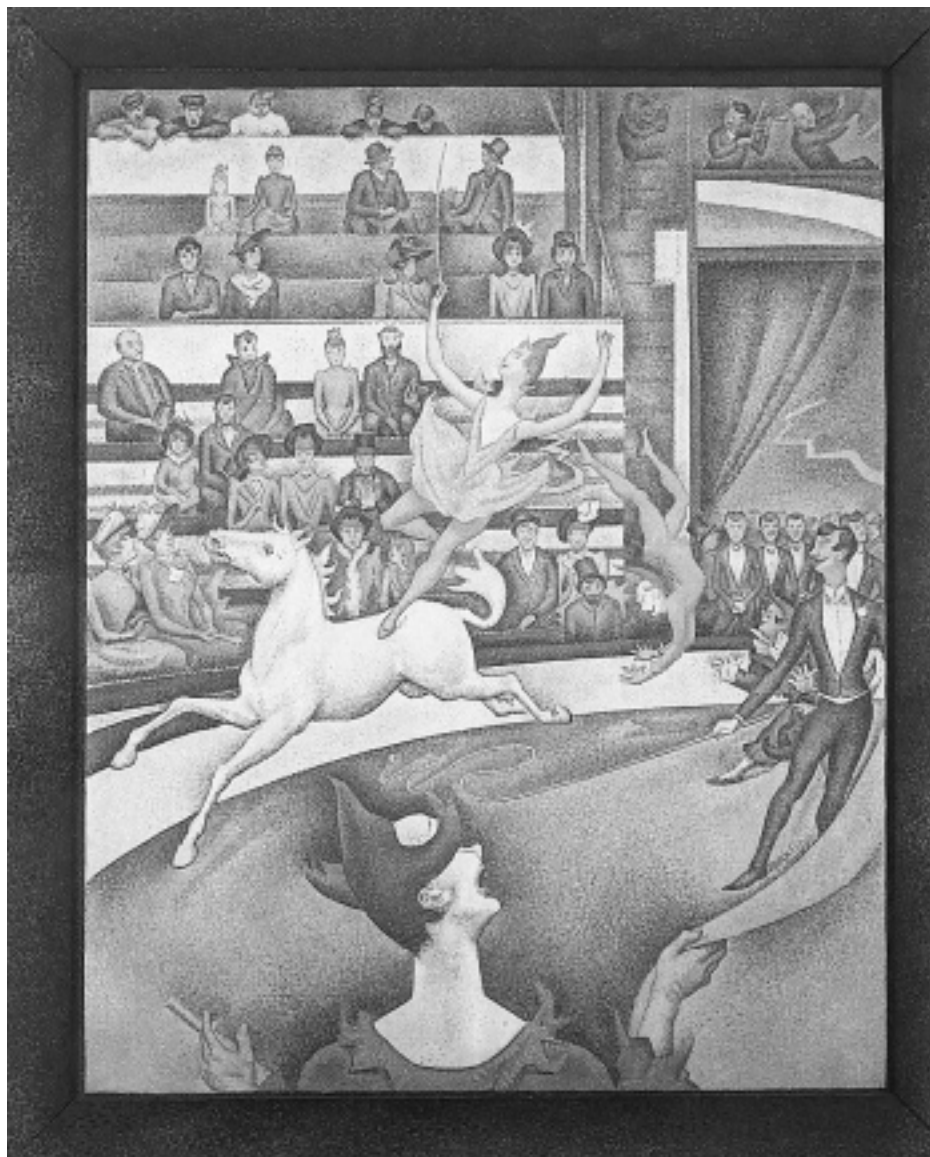

Georges Seurat, Cirque, 1891.

posters of Jules Cheret.²⁷³ There may be a more valuable way to read this painting, one that would amplify its relationship to *Parade de cirque* as well. I believe that Seurat was acquainted in some way with Reynaud or that he had seen at least some of Reynaud's various apparatuses, just as he may have been familiar with Marey's work including his famous "photographic gun."²⁷⁴ It is not unreasonable to pose at least the possibility that Seurat had the opportunity to see some of Reynaud's work. Specifically I suspect he might have seen one particular film strip (*bande*) of circus clowns used in the Praxinoscope a Projection at some point in the late 1880s or in early 1890, but in any case before he had begun to paint *Cirque*.²⁷⁵ Clearly the configuration of the circus ring, the dispersal of the seated crowd, and the startling similarity of the acrobatic clown open the possibility of

273. Seurat's interest in Cheret should not be limited to a question of pictorial ideas or the notion that Cheret was for him some vague metonym for "popular culture." I do not find very useful the pervasive characterization of Cheret, established by Robert Herbert, as "a poet of bubbling imagination, who had at his fingertips a natural gift for bright color and movement. An effervescent *charmeur*; the very epitome of all that was graceful and joyful in modern life, he remains today one of the best interpreters of Paris in her most charming fin-de-siecle moments." Herbert, "Seurat and Jules Cheret," *Art Bulletin* 40 (1958), pp. 156–158. In fact, Cheret's work, from the 1870s into the early twentieth century, coincided with the emergence and practical functioning of consumer culture in its widest manifestations during these years. His posters and graphic designs included not just the frequently reproduced ones of the Folies-Bergere and the circus but also advertisements for pharmaceutical products, cosmetics, kerosene, lighting and heating fixtures, railroads, machines and appliances, beverages, department stores, books, operas, dioramas, panoramas, skating rinks, ballets, resorts, festivals. That is, Cheret's posters, and related advertising, were about a technology of attention and at the same time were a specific "ornamental" representation of commodity culture. Cheret's "personal" style was in fact an abstract luster, a decorative formula that could be applied promiscuously to any possible object of consumption, a degraded counterpart to Seurat's own dream of a universal "style." For an extensive catalog, see Lucy Broido, *The Posters of Jules Cheret* (New York: Dover, 1980). See also Marcus Verhagen, "The Poster in Fin-de-Siecle Paris," in Leo Charney and Vanessa Schwartz, eds., *Cinema and the Invention of Modern Life* (Berkeley: University of California Press, 1995), pp. 103–129.

274. For evidence of Seurat's possible interest in Marey and Muybridge, see Aaron Scharf, *Art and Photography* (Harmondsworth: Penguin, 1968), pp. 230–231, 362–363. We have some indirect hints of the extent of Seurat's interest in the rich texture of entertainment and visual spectacle available at the various fairgrounds or *fetes foraines* in Paris and its outskirts. In addition to the sideshow and circus-related attractions such as costumed monkeys, weightlifters, giants, and ventriloquists, we are told that Seurat also loved the panoramas, wax museums, somnambulists, and visual displays of famous crimes. See the embellished account of his "Baudelairean" immersions in the nocturnal world of the Parisian *forains*, in Gustave Coquirot, *Seurat* (Paris: Albin Michel, 1924), pp. 75–89. For a richly illustrated contemporary chronicle of both the business and spectacle of Parisian fairs and circuses, see Hugues Le Roux, *Les jeux du cirque et la vie foraine* (Paris: Plon, 1889). Of course, this was a milieu in which a whole range of optical apparatuses were available for public consumption, endless variations on the peep show and the magic lantern as well as shadow theaters, large-scale stereoscopes, zoetropes, and other forms of display. On the origins of cinema within this fairground milieu in the 1890s, see the chapter "Prehistoire du cinema forain," in Jacques Deslandes and Jacques Richard, *Histoire comparee du cinema*, vol. 2 (Paris: Casterman, 1968), pp. 85–97.

275. I am indebted to Dominique Auzel for his help in identifying this image. It has been incorrectly described in several publications as an image from "Clown et ses chiens," one of the *Pantomimes Lumineuses* for Reynaud's Theatre-Optique.

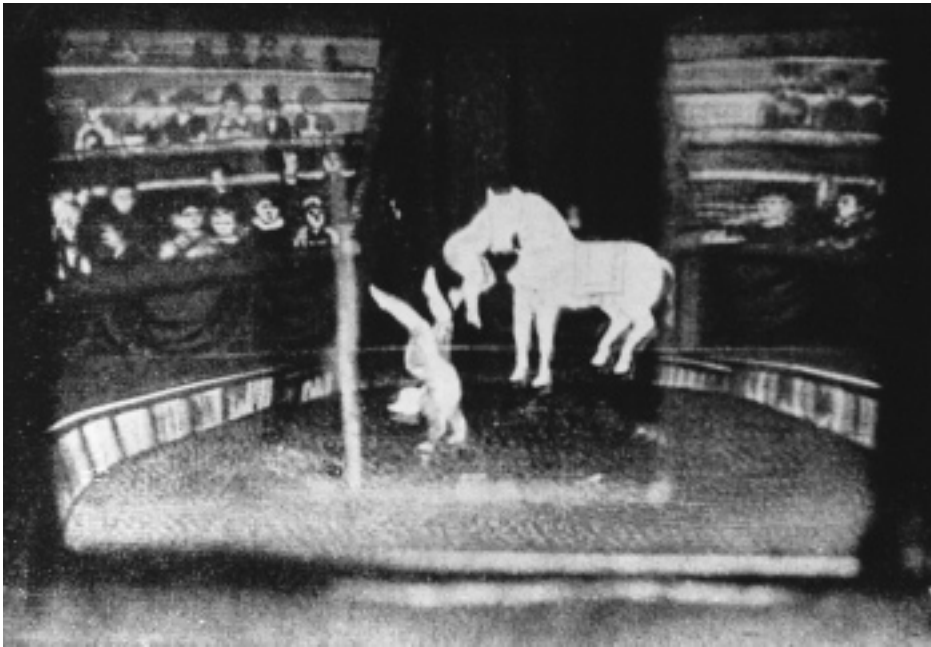

Image from Reynaud's Praxinoscope à Projection.

Seurat having seen this image, perhaps both as an isolated (static) maquette and through viewings of the brief loop in projection. I propose this with some hesitation, because my larger claims about Seurat would remain essentially unchanged without a “provable” link between his work and Reynaud's.²⁷⁶ That is, I am interested in how Seurat's intellectual preoccupations were adjacent to and even

276. Given Seurat's interest in such a wide range of contemporary popular visual culture, it is hardly far-fetched to consider the possibility of contact between him and Reynaud. By 1889 Seurat had moved from his studio off Place de Clichy to nearby 39 Passage de l'Elysee-des-Beaux-Arts (today called the Rue Andre-Antoine), just off the Place Pigalle. Reynaud's establishment on the Rue Rodier was located just a few minutes away. On Seurat and the studio culture of this Boulevard de Clichy area, see John Milner, *The Studios of Paris: The Capital of Art in the Late Nineteenth Century* (New Haven: Yale University Press, 1988), pp. 132–137. On the political culture of this Paris neighborhood around 1890, see Richard D. Sonn, *Anarchism and Cultural Politics in Fin de Siecle France* (Lincoln: University of Nebraska Press, 1989), pp. 49–94. It was also around this time that Seurat became an admirer of the graphic art of Jules Cheret, who might have been a link between the circles of Seurat and Reynaud. Cheret was soon to design posters for Reynaud's Pantomimes Lumineuses at the Musee Grevin and had been producing publicity for the Musee since 1882, including posters for demonstrations of recorded sound, “Auditions Telephoniques,” in 1883 and for the “Black Magic Instantaneous Apparitions” of Professor Carmelli in 1887. Cheret became involved in the direction of the Musee Grevin in 1891. See Schwartz and Meusy, “Le Musee Grevin et la cinematographe.”

aligned with a larger field of perceptual modernization than has been considered in most studies on him.²⁷⁷

As I've suggested, attempts to explain Seurat's attraction to the subject matter of the circus primarily on the basis of its meanings as a "real-life" social phenomenon have never been very satisfying.²⁷⁸ The single-ring urban circus had been around for over a half a century and hardly provided an image of contemporary "modernity," as is often implied in accounts of this painting.²⁷⁹ Rather I believe that part of the importance of the contents of this image—in particular the horse, its rider, and the clown—has to do with them as components of an already constituted space of representation. The space in question is that plural field in the nineteenth century of both actual moving images and the more recent systematic representations of movement as in the work of Marey and Muybridge. Rather than pursue the iconographic significance of the clown and the acrobat, it is important to consider that these motifs, along with jugglers, dancers, and animals, were synonymous with a new experience of form deployed in time, beginning with the phenakistoscope and zoetrope in the 1830s through innumerable optical devices all the way into the 1890s. These devices, endlessly fascinating and repetitive, were sites of attentiveness, or as Tom Gunning says, of "attraction." The fascination had little to do with the figure or motif itself but rather with the illusion of movement, with its pulsing, expanding, and contracting in endless, variably slower or faster, loops of motion. The effects of these displays, regardless of who the audience was, were primarily a kinematics and only secondarily a semantics. The horse, which (despite the advent of the railroad) remained a primary nineteenth-century image of vehicular power and energetic motion, was part of that same early vocabulary of moving images and visual toys, and then, with Muybridge and others, became the object of more sustained, if static, analyses of movement.

277. Even before considering the possibility of a specific link between *Cirque* and Reynaud's work, I had already discussed the historical and aesthetic proximity of Seurat to Reynaud in my "Seurat's Modernity," p. 64.

278. As Henri Dorra noted, "Here it seems that the artist has started out not so much from his direct observation of a real circus, as from some kind of conceptual circus." In Dorra and Rewald, *Seurat*, p. xxx.

279. Seurat's representation of the single-ring circus coincides with the moment, around 1890, when the three-ring circus was being promoted, especially in North America. Economic considerations led to this format, which accommodated a much larger audience, and the tripling of rings dramatically transformed the nature of circus as spectacle. The simultaneity of action in three locations entailed a constant dispersal of attention and diminished what had been the central unifying role of music, which could no longer be synchronized with multiple performances and events. See Paul Bouissac, *Circus and Culture: A Semiotic Approach* (Bloomington: Indiana University Press, 1976), pp. 11–12.



Assorted phenakistoscope imagery, mid-nineteenth century.

At the same time moving images would have suggested a wealth of possible investigations of the dynamogenic or motor properties of visual response. We can again recall Meyer Schapiro's remark about Seurat's predilection for "schematic movement"; but what Schapiro did not consider was Seurat's adjacency to widely prevalent forms of machine vision, which would have provided vivid experiences of such movement.²⁸⁰ There is little value in isolating Seurat from the effects of what Reynaud, Edison, and many others were developing throughout the 1880s and early 1890s: whether we should refer to these experiments as "precinematic" is

280. For details on the immense range of devices available in the late 1880s for the simulation of continuous movement, see Laurent Mannoni, *Le mouvement continué* (Paris: Cinematheque française, 1996).

debatable, but we can certainly designate them as examples of an emerging “industrial art.” As much as Reynaud, Muybridge, or Fuhrmann, Seurat too was a producer of what Jean-Louis Comolli calls “machines of the visible”; his work is also lodged amid the shift from artisanal practices to the repetitive and standardizing industrial modes of image-making.²⁸¹

We could then think of *Cirque* not as a picture of a circus but as a frozen interval of a moving image that happens to be of circus performers. The image becomes like a fragment or section, detached from a continuum of images, that declares its remoteness from the conditions of “natural” perception. The acrobat, the horse, and its rider are all immobilized as if through the exercise of a nonhuman perception, in a simulation of a practice Reynaud effectively inaugurated, the freeze frame or stop action. If Seurat was attracted to techniques such as Reynaud’s, it would have been in part for the way they allowed the constructed and synthetic nature of machine vision to coincide with his own rationalization of perceptual processes. The three figures I’ve just indicated also have that ungrounded, dissociated relation to the interior milieu that Reynaud’s figures have because of his amalgamation of two disjunct projection systems. In this sense, the audience in Seurat’s painting is like one of the static backgrounds used in Reynaud’s machines; but in *Cirque* it conveys the unchanging, unreflective, even unseeing nature of modern spectatorship. This is a crowd of spectators permanently in place, installed as a foundational component of this social world, in which the specific content displayed to them is a matter of absolute inconsequence.

Earlier I had indicated how *Cirque* can seem like an inversion of (and also a release from) the antiscenic austerity of *Parade de cirque*, as if we have been admitted to the voluminous interior that the facade of the earlier painting beckoned us into, yet to which it concealed and prohibited access. However, after the path I’ve just traced, it’s possible to argue that here too we are looking at an equally space-drained image with a related void at its center. The figure of the clown at the bottom of the painting becomes crucial in this reading. This is not a fully completed painting, but there is enough information to suggest that we are looking at a figure who is standing between a beam of light and a flat surface, a figure casting its own shadow onto what might be *the projection* of an image on a two-dimensional surface or screen. There are few other intelligible explanations for the peculiar penumbral shading around the clown’s shoulders, neck, and hat. The

281. Jean-Louis Comolli, “Machines of the Visible,” in Teresa de Lauretis, ed., *The Cinematic Apparatus* (London: Macmillan, 1980).

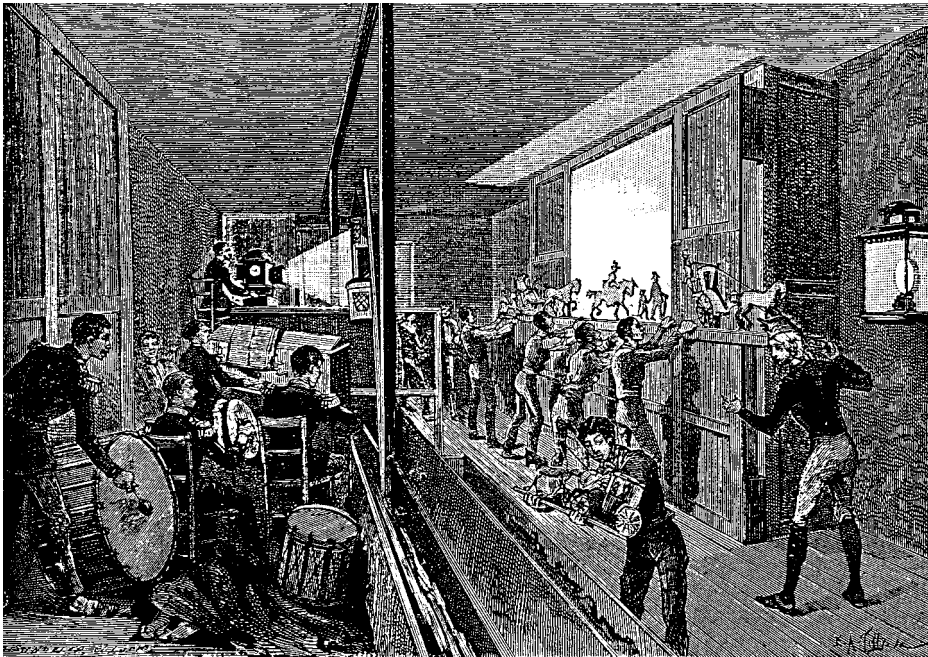

Backstage view of shadow projection performance by Les Ombres françaises, late 1880s.

clown is the incarnation of the magician-engineer who here, with his right hand, opens the curtain onto an illuminated and abstractly assembled plane of visual stimulation.²⁸² This central figure also recalls numerous advertisements for magic lanterns in the late 1880s and early 1890s that depicted stock characters like a dwarf or clown pulling open a curtain to reveal the spectacle of magic lantern projections in use. My point is not to label this painting as a premonition of cinema, but rather to consider it as the product of a historical moment when many forms of projected images were widely available, whether as traditional lantern slides, shadow shows, or in a wide range of projection apparatuses, including Reynaud's. To a painter of Seurat's preoccupations, these would have disclosed the congruence of an immaterial, atopic, and evanescent image with powerful reality effects and techniques of attraction.

282. "In the *Circus* of 1891, it is the phenomenon of spectacle and its concomitant, passive spectatorship, that are at issue. The picture parodies the production of art, allegorized as a kind of public performance, dazzling in its technique, turning somersaults to gratify an immobilized audience." Nochlin, "Seurat's *Grand Jatte*," p. 152.

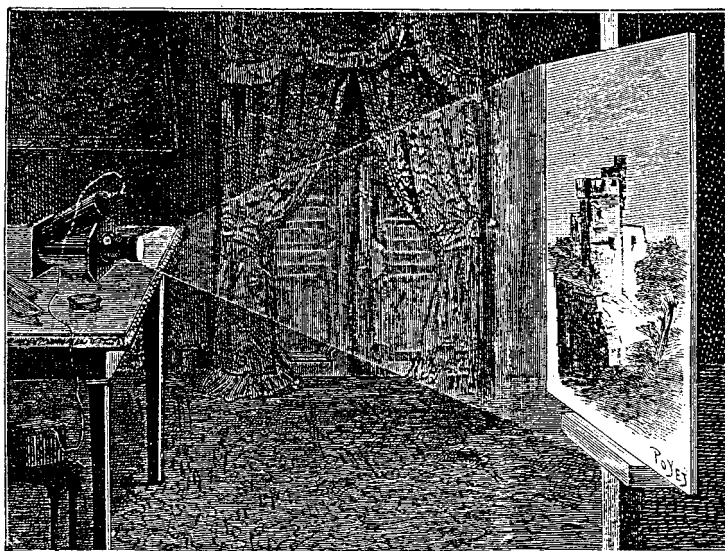
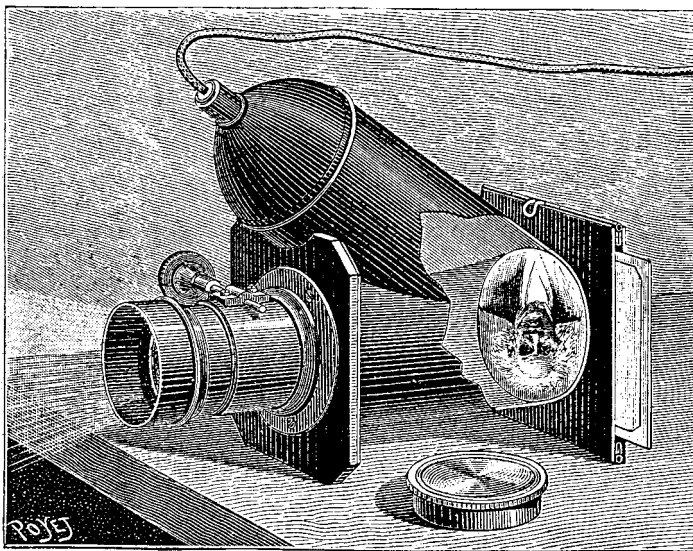

Projector for display of opaque photographs, 1888.



Magic lantern package label, 1890s.

If Seurat was interested in the phenomenon of moving images, which I believe to be a useful hypothesis, it was not for their empirical truth value. Reynaud's work, like the Praxinoscope a Projection, would have shown him a model of animation that was, in principle, compatible with his own composite and synthetic constructions. It had no necessary link to appearances or, more specifically, to the realm of the photographic. The white horse at the left of the painting is a willful renunciation of the limits of empirical fact (and this by the painter who supposedly allied his practice with scientific objectivity). After a decade of international preoccupation with the actual configuration of a horse's legs when in motion, with the new "truths" about animal motion provided by machine vision following Muybridge's studies of the late 1870s, Seurat provocatively presents his horse "incorrectly," in the anachronistic *ventre a terre* position, almost as a refutation of the scientific verisimilitude so often (and misleadingly) associated with Muybridge.²⁸³ Along with the astonishing deformation of the acrobat's body, the horse is an an-

283. Seurat's "incorrect" horse can be affiliated with the animals in Gericault's *Epsom Derby* from seventy years earlier. The point is less that Gericault represented his horses erroneously than that his work



Théodore Géricault, Epsom Derby, 1821.

nouncement that the painting is not a re-presentation of any actual event. Rather Seurat demonstrates how an alliance of art (e.g., Reynaud's drawing) with techniques of perceptual modernization constitutes an autonomous space of invention and imposes its own constructed visions and truths on viewers. The mechanization

is one of the earliest dreams of an impossible and inhuman vision, of a desire for a perceptual ubiquity exceeding the spatial and temporal limits of human faculties. The related ambition of Seurat is not to emulate the high-speed recording machines of Marey and Muybridge, but to remake the self into a sovereign eye that would create and impose its own truths. The horses of both Géricault and Seurat, in their airborne oneiric trajectories, incarnate a deeper truth of the body. They become abstract correlates of physiological and kinetic response to perceived movement; they affirm the primacy of ideomotor experience rather than the truth of mechanical spatial movement. Seurat thus chooses a very different path from Ernst Meissonier, who in the 1880s anxiously sought to reconcile his equine imagery with Muybridge's work. See the important account of Muybridge and Meissonier in Marc C. Gotlieb, *The Plight of Emulation: Ernst Meissonier and French Salon Painting* (Princeton: Princeton University Press, 1996), pp. 171–184.

of vision had no intrinsic link to objectivity or veracity but rather to new capacities for simulation, illusion, conjuration.

Clearly this is an image in which Seurat is experimenting with the management of attention and techniques of attraction. In his use of the dark, wide frame, he is attempting his own reinvention of a “Bayreuth effect,” an effect analogous to the autonomous luminous field of Reynaud’s projected color images. At the same time he is openly manipulating the artifice and abstraction inherent in those techniques. The clown’s shadow cast onto the image dismantles the apparent unity of the space contained by the frame. The impossible frozen character of the image establishes it as a detachable or unbound component of a larger machinic synthesis or binding of images into the simulation of movement. Even though *Cirque* has long seemed an explicit, even inordinate demonstration of dynamogenic effects, it produces a stasis no less powerful than *Parade de cirque*. The inelegant austerity with which the “moving” figures and animal are *arrested* announces that “presence” here is not directly accessible to human vision but can only be the product of technical procedures of simulation. The collapse of scenographic space in *Parade de cirque* is the very precondition for the impossible, unseeable apparition which is the spectacle in *Cirque*. The whole bureaucratization of response and affect in Seurat, regardless of the physiological provocation implied, is fully compatible with the phantasmal homeostasis of *Parade de cirque* and with a de-temporalization of both individual and collective experience.

If *Cirque* can be read as the other side or interior of *Parade de cirque*, it is no less an abstract conceptualization of perceptual experience. If the possibility of spectacle in *Parade de cirque* is deferred, displaced, and denied, the image of spectacle that is seemingly displayed in *Cirque* is equally derealized and drained of presence. But the social world that Seurat diagrams for us in both of these images is one in which the attentiveness of an observing subject is the site of increasingly specialized operations of power. Durkheim’s hoped-for solidarities are redrawn here as collective states in which a delimited and managed field of stimuli maintains a twilight state of restricted consciousness, in which the autonomy of the individual is reduced. The importance of Seurat’s work, in these last years of his brief career, was to have intuited how the collapse of scenic space allowed new imaginary figurations of immediacy, of a regressive unity based on a corporeal engagement of the spectator. As early as anyone, he sensed something fundamental about the industrialization of contemplation, and like Wagner he anticipated, before the actual inception of cinema, the effects of a phantasmic luminous image



Sideshow outside Cinematographe, late 1890s (note sign with ticket prices).

on which essence had been displaced by appearance.²⁸⁴ The formal harmony into which he sought to fashion his work certainly presumes an escape into psychological time, but he never completely erases a sense of the obdurate historical conditions out of which this dream of equilibrium emerges. Unlike Wagner and others, Seurat resisted the temptation of the phantasmagoric and of myth, both through his exposure of the technical premises of his work and the parallel subversion of any stable “formation” or Gestalt on which the allure of myth depends.²⁸⁵ His work

284. See Carl Dahlhaus, *Nineteenth-Century Music*, trans. J. Bradford Robinson (Berkeley: University of California Press, 1989), pp. 195–196.

285. If we choose to label Seurat’s work as “avant-garde,” it would be within the terrain of Benjamin Buchloh’s valuable delineation of this term: “It seems more viable to define avant-garde practice as a continually renewed struggle over the definition of cultural meaning, the discovery and representation

is clearly adjacent to larger processes of modernizing human perception, but it is hardly identical with them. As an artwork, *Parade de cirque* is still, in Adorno's words, an object "incompatible with the forces that want to humble and subsume it."²⁸⁶ It may be built out of mechanisms for the production of subjective response (and it is irrelevant whether or not they are effective), but it is never reducible to them. At the same time, in its opacity, in its hostility to virtuosity and expressionism, it prevents any consoling eclipse of self in the work. It leaves its viewer hovering between submission to its empirical operation and anticipation of a luminous fusion of all that is unreconciled in it.

of new audiences, and the development of new strategies to counteract and develop resistance against the tendency of the ideological apparatuses of the culture industry to occupy and control all practices and spaces of representation." Buchloh, "Theorizing the Avant-Garde," *Art in America*, November 1984, p. 21. See also the related discussion in Ward, *Pissarro, Neo-Impressionism, and the Spaces of the Avant-Garde*, pp. 263–265.

286. Adorno, *Aesthetic Theory*, p. 264.

FOUR

1900: Reinventing Synthesis

But freedom always remains that vision, that silence in which all voices echo. It is always attention which creates time, wins time, so that all these voices speak distinctly, in a succession.

—Paul Ricoeur, *Freedom and Nature*

Art historian Meyer Schapiro characterized the work of Cézanne as “an art of grave attention.” Schapiro’s use of this phrase was carefully weighed, informed by his own discernment of the paradoxes involved: “It is the art of a man who dwells with his perceptions, steeping himself in this world of the eye, though he is often stirred. Because this art demands of us a long concentrated vision, it is like music as a mode of experience—not as an art of time, however, but as an art of grave attention, called out only by certain works of the great composers.”¹ Schapiro elucidates the notion of a “long concentrated vision” by reference to a nonoptical experience, and he poses Cézanne’s sustained attentiveness, occurring out of time, as a suspension of perception, a hovering within a drawn-out moment, in which a dynamic play of relationships results in “a restoration of objects.” Whether or not there really is any “restoration” in Cézanne’s late work has been central to the most important debates about this artist, and in this chapter I will examine how the particular reinvention of synthesis in his work from around 1900 raises a very different set of problems than in Manet and Seurat. The partial recourse by those artists to strategies of binding, homeostasis, and fixation is no longer an option for

1. Meyer Schapiro, *Cézanne* (New York: Abrams, 1963), p. 9.

Cézanne. Through Cézanne's late work I will explore the uncertain status of an attentive observer in a range of locations around this time, in works of philosophy, scientific psychology, early cinema, art theory, and neurology. My aim is not to identify a set of homologous objects but rather to highlight the highly *contested* nature of questions of attention and perception at the end of the century. These problems took shape around many, often radically different positions and practices concerning the possibility of "pure perception," and the possibility of "presence" within perception. I will be concerned here with how the notion of attentive presence was recreated amid the impact of new conceptualizations and organizations of motion, memory, and temporality, including emerging technological arrangements. By the late 1890s the very possibility and value of a sustained looking, of a "fixed" vision, became inseparable from the effects of dynamic, kinetic, and rhythmic modalities of experience and form.



Schapiro's remarks can serve as an entry into another contemporary "attentive" practice, or at the least the discursive proposal of such a practice, in the early work of Edmund Husserl. A number of influential accounts of Cézanne's work have associated it in general ways with aspects of early twentieth-century phenomenology. In brief, what the two supposedly have in common is an attempt to bypass the accumulated cultural and commonsense assumptions about the world as it appears in consciousness, an attempt described in Cézanne's words as: "to produce the image of what we see while forgetting everything that has appeared before our day."² The dubious assumption here is that a Cézannean venture of "forgetfulness" corresponds to Husserl's goal of the isolation of a "pure" form of consciousness, stripped of all the accretions of habit and socialization. According to Merleau-Ponty's well-known account, Cézanne sought "a vision which penetrates right to the root of things beneath the imposed order of humanity," and establishes a position vis-a-vis the world that is prior to distinctions between mind and body, thought and vision.³ Cézanne, he wrote, "returns to just that pri-

2. Paul Cézanne, letter to Emile Bernard of October 23, 1905. Reprinted in *Conversations avec Cézanne*, p. 46. At the same time, the long nineteenth-century preoccupation with an "innocent vision" is not unimportant here, including Ruskin but also Schopenhauer who declared, "To have original, extraordinary thoughts, possibly even immortal ideas, it is sufficient to become so completely estranged from the world and things for a few moments that the most ordinary objects and events appear to be wholly new and unfamiliar, whereby their true nature is disclosed." Arthur Schopenhauer, *Parerga and Paralipomena*, vol. 2 (1851), trans. E. F. J. Payne (Oxford: Oxford University Press, 1974), p. 77.

3. Maurice Merleau-Ponty, *Sense and Non-Sense*, trans. Hubert L. Dreyfus and Patricia A. Dreyfus (Evanston: Northwestern University Press, 1964), p. 16.

mordial experience from which these notions are derived and in which they are inseparable.”⁴ Cezanne’s work, in this view, provides a purified route of access to things-in-themselves, parallel to Husserl’s own appropriation of a visual model to his quest for “seeing essences.”⁵

First, let’s consider further Husserl’s stake in these problems, or to what extent it might be worthwhile to treat them as common problems. In the very late 1890s, in the pre-phenomenological *Logical Investigations* (a work that contains a comprehensive theory of perception), Husserl declared his opposition to prevailing notions of attention.⁶ He wanted to define an intuition fundamentally different from an attention that was merely a heightened awareness of a narrowed or focused range of perception. According to Jacques Derrida, Husserl’s aim in the *Logical Investigations* was the description of objectivities “in a certain atemporal fixedness,” which entailed “the fixing of attention on the formal.”⁷ In this text Husserl writes: “Men speak of attention as if it were a name for modes of special *relief* imparted to experienced contents.”⁸ Husserl here is countering dominant psychological models of attention, such as Wundt’s, and the sculptural metaphor is tied into the well-established idea of attention as an operation of selection, in which a given set of stimuli are perceived as if three-dimensional in relation to a more flattened-out apprehension of a surrounding field. But Husserl is calling for a dramatic reorientation of such a notion and argues that attention is unrelated to either empirical observation or traditional introspection; it is not a question of the mere existence of a content in consciousness.⁹ “Nothing has so hindered right views in

4. Ibid.

5. Edmund Husserl, *Phenomenology and the Crisis of Philosophy*, trans. Quentin Lauer (New York: Harper & Row, 1965), p. 111.

6. Many commentators consider the two volumes of *Logical Investigations* to belong to distinct phases of Husserl’s thought—the first volume associated with his “pre-phenomenological” years in Halle and the second volume with his first articulations of phenomenology as a limited epistemology.

7. Jacques Derrida, “‘Genesis and Structure’ and Phenomenology,” in *Writing and Difference*, trans. Alan Bass (Chicago: University of Chicago Press, 1978), p. 155.

8. Edmund Husserl, *Logical Investigations* (1899–1901), vol. 2, trans. J. N. Findlay (New York: Humanities Press, 1970), p. 585; emphasis added. Husserl develops this notion of attention as that which “differentiates” and “throws into relief,” in *The Phenomenology of Internal Time Consciousness* (1905–1910), trans. James S. Churchill (Bloomington: Indiana University Press, 1964), pp. 175–181. Here he details the primordial operation of “the directed glance of attention.”

9. See Harrison Hall, “Was Husserl a Realist or an Idealist?,” in Hubert L. Dreyfus, ed., *Husserl, Intentionality, and Cognitive Science* (Cambridge: MIT Press, 1982), p. 174: “Phenomenological reflection is reflection which shifts the focus of attention from the objects of ordinary experience to the noemata which mediate such experience. . . . Thus, disconnecting the objective reference from the meaning of the perceptual act is not simply a matter of shifting attention within the natural context of experience, but of transforming or abandoning that context as well.”

this field as the by-passing of the fact that attention is an emphatic function which belongs among acts in the above defined sense of intentional experiences. . . . There must be a basic act in which what we attend to becomes objective, becomes presented in the widest sense of this word.”¹⁰ Husserl believed that, in spite of all the study of attention in the late nineteenth century, he was the first to grasp the significance of the connection between attention and intentionality.

Husserl’s work, like Cézanne’s, is one of many sites in the late nineteenth century where a crisis in perception is diagnosed, but it is also one of the most singular and implacable responses to such a crisis. Part of what he attacks as “psychologism” in the late 1890s are epistemological positions that were the targets of others as well: various psychophysical, associationist, sensationalist, atomistic accounts of perception and cognition.¹¹ Helmholtz’s *Optics*, aligned as it was with his theory of unconscious inferences, was one of the foundations for subsequent nineteenth-century epistemological positions that began with *physiological* premises in order to demonstrate how merely “reliable” and “consistent” knowledge about the world was possible. Husserl clearly found deplorable the idea of consciousness as a bundle of sensations, as repeated associations or fusions of psychological contents. His response was not to restore a perceiving subject to a privileged point of view from which the objectivity of the world could be apprehended (as in classical models of vision). Nor did he refute any empirical or physiological claims about perception. Rather he posed the possibility of a parallel, alternative model of intuition that allowed a more purified and fundamental understanding of the nature of experience, and which revealed the inevitable intertwining of subject and object. Issues of cognitive and perceptual *synthesis* were not primary because of his position (important for the Gestaltists) that the material of perception is given with much of its order and organization directly.

10. Husserl, *Logical Investigations*, vol. 2, pp. 586–587. It should be noted that Husserl responded creatively to William James’s work on attention. Although Husserl destroyed most of his notes and research materials from before 1900, “his copy of the *Principles of Psychology* . . . shows intensive markings, chiefly in the first volume, and specifically in Chapter 9 (The Stream of Thought) and Chapter 11 (Attention).” Herbert Spiegelberg, *The Phenomenological Movement: A Historical Introduction*, 2d ed., vol. 1 (The Hague: Martinus Nijhoff, 1965), p. 114.

11. On the larger background to Husserl’s refutation of psychologism, as he saw it in the work of Mill, Bain, Wundt, Sigwart, Dilthey, Lipps, and others, see the valuable historical survey in Martin Kusch, *Psychologism: A Case Study in the Sociology of Philosophical Knowledge* (London: Routledge, 1995). See also Thomas M. Seebohm, “The More Dangerous Disease: Transcendental Psychologism, Anthropologism, and Historism,” in Mark A. Notturmo, ed., *Psychologism* (Leiden: E. J. Brill, 1989), pp. 11–31. For a consideration of the relation between psychologism and aesthetic modernism, see Martin Jay, *Cultural Semantics: Keywords of Our Time* (Amherst: University of Massachusetts Press, 1998), pp. 165–180.

However one characterizes the philosophical significance of his efforts to resecure an unconditional basis for logic and science, the less lofty cultural importance of Husserl's work must be seen as one of a range of attempts (including Cézanne's) to escape from reified, habitual patterns of perception inherent in various aspects of the rationalization and commodification of experience in the 1890s and early 1900s. One of his central problems (and it's a problem that relates to issues in Cézanne) was to explain how the realm of the psychological, which is intrinsically one of perpetual modulations, fusions, entrances and exits of contents, can yield stable, objectively valid cognitions. The very idea of attention as a malleable, entropic force susceptible to fatigue, distraction, and external management would have been unacceptable to Husserl. The dynamic, kinetic, distracted texture of modern sensory life could be tolerable only if there was a guarantee that beneath it, over it, or embedded in it was access to the primordial oneness of consciousness. The fragmentation, dissociation, and fluctuations of ordinary perceptual experience concealed what was actually invariant and constitutive of those perceptions. The widespread interest in nineteenth-century psychology in the study of optical illusions, like the reversible Necker cube or the deceptively longer and shorter Müller-Lyer lines, continually raised questions about the relativity of individual perception, in both nativist and empiricist explanations. For Husserl, such relativity could not be part of a quest for the logic of meaning.

Husserl's work proposes the possibility of an impersonal, preindividual transcendental sphere, free of anything empirical, of anything spatiotemporal, to which attention appertains. His remaking of attention is a move from the empirical to the universal, in which attention ceases to be "natural" and becomes an intentional act with an absolute structure. Here is a quote from the first volume of the *Logical Investigations*: "Significant talk of attention embraces the whole sphere of thinking and not merely the sphere of intuition. . . . If our judgement is of the form All A's are B's, our attention is given to this universal state of affairs, we are concerned with allness, and not with this or that single matter."¹² Conceived in this way, attention becomes allied with a process of abstraction, in which the universal itself is "given." It is an attention that bypasses everything nonformal, so that the purely formal aspects of the world can be discovered.

Over the following decade Husserl would develop this notion of attention into an image of a projected ray of light, a searchlight, the "attentional beam"

12. Husserl, *Logical Investigations*, vol. 1, p. 383.

illuminating not objects and empirical relations but essences and noema.¹³ Attention, as a searchlight beam, becomes a quasi-machinic figure for an unwavering mode of looking at the act of looking, and thus for a suspension of the “natural attitude.”¹⁴ According to Michel Foucault and other critics, Husserl is seeking to preserve the rootedness and stability of the observer and the coordinates of so-called “natural perception,” including a primal horizon against which allegedly unconditional perceptual meanings can arise. Gilles Deleuze insisted that Husserl and phenomenological thought in general were unable to go beyond what are essentially “pre-cinematographic conditions,” in which movement can be thought only from the anchorage of a static “pose.”¹⁵ In a world in which previously stable meanings, signs, social relations were being uprooted, made exchangeable, and put into circulation, Husserl aims to discern a halo of absolute authenticity around every object or set of relations. Amid the dynamic dissolutions of modernization, he proposes a monolithic technique of attention that will impose a unity, clarity, and consistency on the most dispersed, ambiguous, and kinetic of psychic contents. In order to salvage the authenticity of a subjective lifeworld, Husserl initiated a hopeless quest to determine its *universal* structure.¹⁶

Despite all of the obvious incommensurability between the projects of Cézanne and Husserl, they both must be understood and positioned in relation to

13. Edmund Husserl, *Ideas: General Introduction to Pure Phenomenology* (1913), trans. W. R. Boyce Gibson (New York: Collier, 1962), pp. 248–249. The idea of attention as a radiant beam occurs in many widely differing bodies of thought. For uses of a “spotlight” theory in recent studies on attention, see, for example, A. M. Treisman, “Features and Objects,” *Quarterly Journal of Experimental Psychology* 40 (1988), pp. 201–237; and M. I. Posner and S. E. Peterson, “The Attention System of the Human Brain,” *Annual Review of Neuroscience* 13 (1990), pp. 25–42.

14. Albert Camus lucidly discusses Husserl’s model of attention, freely explicating it thus: “From the evening breeze to this hand on my shoulder, everything has its truth. Consciousness illuminates it by paying attention to it. Consciousness does not form the object of its understanding, it merely focuses, it is the act of attention, and, to borrow a Bergsonian image, it resembles the projector that suddenly focuses on an image. The difference is that there is no scenario, but a successive and incoherent illustration. In that magic lantern all the pictures are privileged. *Consciousness suspends in experience the objects of its attention.* Through its miracle it isolates them. Henceforth they are beyond all judgments.” Camus, *The Myth of Sisyphus and Other Essays*, trans. Justin O’Brien (New York: Knopf, 1955), p. 43; emphasis added.

15. See Michel Foucault, *Language, Counter-memory and Practice*, trans. Donald F. Bouchard and Sherry Simon (Ithaca: Cornell University Press, 1977), pp. 175–176; Gilles Deleuze, *Cinema 1: The Movement-Image*, trans. Hugh Tomlinson (Minneapolis: University of Minnesota Press, 1986), pp. 58–61.

16. According to Francisco Varela, “The irony of Husserl’s procedure, then, is that although he claimed to be turning philosophy toward a direct facing of experience, he was actually ignoring both the consensual aspect and the direct embodied aspect of experience. . . . Husserl’s turn toward experience and ‘the things themselves’ was entirely *theoretical*, or, to make the point the other way around, it completely lacked any *pragmatic* dimension.” Varela argues that this criticism holds as well for Merleau-Ponty, who stressed the “embodied context of human experience but in a purely theoretical way.” Varela, *The Embodied Mind* (Cambridge: MIT Press, 1993), pp. 17–19.

processes of rationalization and modernization. As I've already emphasized, attention emerges as a discursive and practical object at the historical moment when vision and hearing have become progressively severed from the various historical codes and practices that had invested them with a level of certainty, dependability, and naturalness. The more the senses are revealed to be inconsistent, conditioned by the body, prey to the threat of distraction and nonproductivity, the more a normative individual is defined in terms of objective and statistical attentional capacities that facilitate the subject's functional compatibility within institutional and technological environments. In spite of Cezanne's and Husserl's relative remoteness from these arenas of production and consumption, their work challenged and sought to exceed the same features of perception which those apparatuses regulated and standardized.

What are we to make, then, of the familiar theme of Cezanne's will to forget? What, if anything, did he seek to "suspend"? It has long been said of Cezanne that he never acquired the *trucs* or gimmicks of the atelier, that he sought to rid himself of ready-made schema and traditional solutions for pictorial organization (for example, the historically accumulated practices associated with linear perspective). But if these accounts of Cezanne as a kind of primitive, avoiding any premade interpretations of the world, are useful, it is for how they suggest his particular sensitivity to and observation of perceptual experiences that had been ignored, marginalized, or been incompatible (and hence unarticulated) within older (classical) organizations of knowledge about vision. Rather than attempting to lodge him within a nineteenth-century mythology of the "innocent" or infantine eye, Cezanne must be thought of as an observer who was astonishingly alert to whatever was anomalous in perceptual experience. In his late work, he is not working with a perceptual tabula rasa from which to build afresh the essential structure of the world; rather he has become open to engaging a discordant exterior which acts on him, jarring his hold on a recognizable world.

Beginning in the early nineties, with his abandonment of the unifying all-over constructive touch of the so-called third period (1878–1887), Cezanne enters into a project of unprecedented experimentation.¹⁷ One of the discoveries he made over the next decade is that perception can take no other form than the process

17. Lawrence Gowing discusses the "riddle" of the disintegration of the object in the late work. "Cezanne's work from 1900 onward is radically different from the object-based structures of earlier years. . . . After 1900 separable objects in Cezanne's work increasingly merge into the flux of color." Gowing, "The Logic of Organized Sensations," in William Rubin, ed., *Cezanne: The Late Work* (New York: Museum of Modern Art, 1977), p. 55.



Paul Cézanne, *Mont Sainte-Victoire*, c. 1902–1904.

of its formation. This is no longer a question of recording the evanescent appearances of the world but of confronting and inhabiting the instability of perception itself. Perhaps more piercingly than anyone else, Cézanne disclosed the paradoxes of attention through an understanding of perception's essential *difference from itself*.¹⁸ What Manet had partially intuited became a productive part of Cézanne's practice—the creative discovery that looking at any one thing intently did *not* lead to a fuller and more inclusive grasp of its presence, its rich immediacy. Rather, it led to its perceptual disintegration and loss, its breakdown as intelligible form;

18. Jacques Derrida's critique of Husserl contains one of the most influential accounts of the impossibility of a self-identical perception, an account that also has relevance for an analysis of temporality in Cézanne: "One then sees quickly that the presence of the perceived present can appear as such only inasmuch as it is *continuously compounded* with a nonpresence and nonperception, with primary memory and expectation (retention and protention). These nonperceptions are neither added to, nor do they *occasionally* accompany, the actually perceived now; they are essentially and indispensably involved in its possibility." Derrida, *Speech and Phenomena*, trans. David B. Allison (Evanston: Northwestern University Press, 1973), p. 64.

and that breakdown was one of the conditions for the invention and discovery of previously unknown relations and organizations of forces. That is, attention was part of a dynamic continuum in which it was always of limited duration, inevitably decomposing into a distracted state or a state incapable of maintaining what had initially seemed like a grip on an object or constellation of objects. In the same way the clarity associated with the intense fixation of vision on an isolated point is continuous with the dissolution of clarity that any fixation produces. For Cézanne, the dissolution inherent in attentiveness not only supported his radical desymbolization of the world but also produced an interface with a perpetually modulating set of relations between what had been thought of as “external” events and sensations. Thus one of the first casualties of his retrained attentiveness was any assumption of perceptual constancy.

We will never know the nature of Cézanne’s elusive “goal” that he mentioned several days before his death. Was it a “harmony parallel to nature,” or “the realizing of one’s sensations”? He may well have started out believing that his goal was, as several critics have claimed, some notion of “spatial unity.” But the final destination was somewhere else, necessarily beyond the inadequate language available to him for the verbal elucidation of experiments that were overwhelming in their novelty. Examining Cézanne through the problem of attention reveals how his work coincides with much more than a domain of the optical, and how it is the product of a broader corporeal engagement. To what then was Cézanne attentive, if not exclusively to the activity of the eye, to visual sensation, to wavelengths of light? Perhaps, in spite of himself, he became attentive to the body, its pulsings, its temporalities, and to the intersection of that body with a world of transitions, of events and of becoming. Clearly he became intuitively aware of the myriad intricacies of subjective vision, and of ways in which physiological limitations condition all sensory experience. One valuable hypothesis about his late work is that he became increasingly sensitive to this discontinuous composition of the visual field, especially to its “concentric” format.¹⁹ Before examining Cézanne further, I want to briefly indicate how powerful institutional reformations of vision in the late nineteenth century had confronted some of these problems.

19. See Gowing’s extraordinary insights into Cézanne’s “abandonment of the prime hypothesis of plane perspective.” He associates his optical preoccupation with an ever-shifting “culminating point” with the fact that “random color mutations were noted in groups of brush strokes in contrasting directions, beginning to form into discrete patches, with no reference to separable objects, amounting sometimes to a whirling blizzard of color changes, which left an even deposit of apparently random color differentiations.” Gowing, “The Logic of Organized Sensations,” pp. 57–58.

Scientific research in the late nineteenth century confirmed what had always been available to naive observation, now systematized for the first time into a comprehensive account of human perception: the disjunct nature of the visual field, in both a physiological and a subjective sense. Empirical studies showed that the central area of the retina—the fovea—was tightly packed with photoreceptor cells, whereas the peripheral areas of the retina had a much sparser distribution of them. This small foveal area gave the greatest detail and most acute color vision, while the larger peripheral or fringe areas provided only vague, indistinct, or even distorted impressions with little clarity or color. The periphery was, however, highly sensitive to movement. By the 1850s scientists were attempting to determine the capacities of the retina in terms of zones of varying sensitivity.²⁰ After several centuries during which the visual field was conceived to be like a conal section of homogeneous clarity and range, the notion now developed that most of what we saw at any given moment hovered in an irreducible vagueness, in which a reading of space or distance was not possible. It was a major shift that led to a reformulation of how a subjective visual field came into being: not through an instantaneous intake of an image but through a complex aggregate of processes of eye movement that provisionally built up the appearance of a stable image.²¹ It was only in

20. Empirical information on foveal and peripheral vision was summarized in Hermann von Helmholtz, *Treatise on Physiological Optics*, ed. James P. C. Southall (New York: Dover, 1962), vol. 2, pp. 331–338. See also the account in Edwin G. Boring, *Sensation and Perception in the History of Experimental Psychology* (New York: D. Appleton-Century, 1944), pp. 172–173. For more recent accounts of these problems, see Julian Hochberg, “The Representation of Things and People,” in Maurice Mandelbaum, ed., *Art, Perception and Reality* (Baltimore: Johns Hopkins University Press, 1973), pp. 65–70, and Robert L. Solso, *Cognition and the Visual Arts* (Cambridge: MIT Press, 1994), pp. 20–26. A range of positions emerged in the late nineteenth and early twentieth century questioning Helmholtz’s assertion that visual acuity depended only on the separation of receptor areas in the retina. Ewald Hering was one of the most notable who argued against Helmholtz (in work published between 1905 and 1909) that acuity did not correspond strictly to localized anatomy but rather was the product of a dynamic relation of fovea and periphery as well as external luminous factors. See his *Outlines of a Theory of the Light Sense*, trans. Leo M. Hurvich and Dorothea Jameson (Cambridge: Harvard University Press, 1964), pp. 153–171. Based on his research in the early 1920s, Kurt Goldstein asserted that “there is no consistent relation between a particular part of the retina and a particular function, and the contribution of any part of the retina to the total performance changes according to the task with which the organism is confronted. . . . Visual acuity depends on the pattern of excitation of the entire retina and on the general attitude of the organism toward the object.” Goldstein, *The Organism: A Holistic Approach to Biology* (1934; New York: Zone Books, 1994), pp. 61–62.

21. “Ears have nothing corresponding to the *fovea centralis*; consequently the indispensable shifting of attention within the auditory field does not involve any parallel shifting of the bodily organ. The discriminating and selecting of auditory *sensa* can be done by the mind alone, and do not require corresponding movements of the ears.” Aldous Huxley, *The Art of Seeing* (New York: Harper and Row, 1942), p. 44. At the same time it should be noted that hearing is also an *aggregate* perceptual process. Michel Chion notes that “we need to correct the formulation that hearing occurs in continuity. The ear in fact listens in brief slices and what it perceives and remembers *already* consists in short syntheses of two or three seconds of the sound as it evolves. . . . We don’t hear sounds, in the sense of recognizing them, until shortly after we have perceived them.” Chion, *Audio-Vision: Sound on Screen*, trans. Clau-

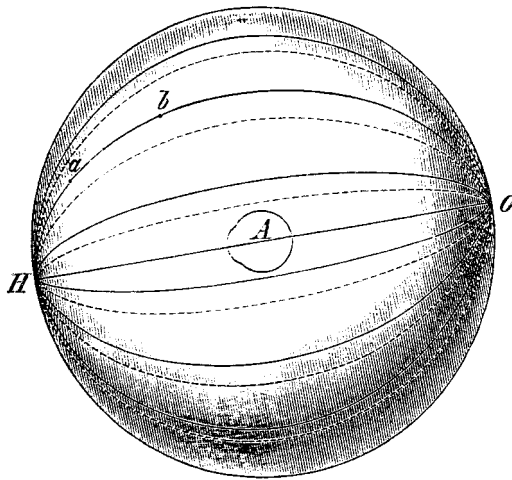

Wundt's spherical representation of the visual field, from *Grundzüge der physiologischen Psychologie*, 1880. Point H denotes the Blickpunkt, and the projections of meridian circles denote the variable extent of the Blickfeld.

1878 that the French scientist Emile Javal (who had translated Helmholtz's *Optics* into French) formalized an understanding that vision occurs in terms of short fast jumps, which he termed "saccadic" movements. Most significant about this new physiological schema of a disjunct field is that it became part of new *psychological* models of the human subject. While it is no longer significant on an empirical level, it can certainly stand as an early instance of a whole range of twentieth-century models in which visual experience is the *composite* product of highly segregated activities, whether in the retina or in the visual cortex.

One of the most influential instances of such research was the work of Wilhelm Wundt, who in the 1880s declared: "Consciousness is regarded as a field of vision: objects enter it and are at first only obscurely and indefinitely perceived, as those visual objects whose images enter the field of the eye at the sides of the retina. Time is required for the objects to arrive at the spot of clear vision . . . where discerning attention is bestowed on them and they are *apperceived*."²² Wundt's schema was based on a distinction between what he called *Blickfeld* and

dia Gorbman (New York: Columbia University Press, 1994), pp. 12–13. See also the extended analysis of the relation between sight and hearing in Hans Jonas, *The Phenomenon of Life: Toward a Philosophical Biology* (New York: Harper and Row, 1966), pp. 135–156.

22. Wilhelm Wundt, *Grundzüge der physiologischen Psychologie* (1874; Leipzig: Engelmann, 1880), vol. 2, pp. 85–92. See also the related account in George T. Ladd and Robert Sessions Woodworth, *Elements of Physiological Psychology*, new ed. (New York: Scribner's, 1911), p. 483. For relevant discussions of Wundt, see Thomas H. Leahey, "Something Old, Something New: Attention in Wundt and Modern Cognitive Psychology," *Journal of the History of the Behavioral Sciences* 15 (1979), pp. 242–252; and George Humphrey, "Wilhelm Wundt: The Great Master," in Benjamin B. Wolman, ed., *Historical Roots of Contemporary Psychology* (New York: Harper and Row, 1968), pp. 275–297.

Blickpunkt, between an overall visual field on one hand and a localized point of focus or clarity on the other.²³ This model was to become enormously influential over the next two decades in various accounts of epistemological, perceptual, and psychological subjectivity.²⁴ The *Blickfeld* for Wundt was the field of consciousness, of conscious awareness, while the *Blickpunkt* was the focus of consciousness where apperception occurred, effectively synonymous with attention. Consciousness here was based on an optical model, but one fundamentally different from, for example, the model of the camera obscura used by Locke, Descartes, Leibniz, and others. Wundt worked with a “topological” or spatially extended model of consciousness and attention in which there was a continuum from impressions initially only dimly apprehended in the *Blickfeld* to their clear and active perception at the attentive *Blickpunkt*. Students in Wundt’s laboratory worked for several decades quantifying the difference in the time it took a subject to perceive the entrance of a stimulus into the general vague field of awareness and the time it took for the same stimulus to become an object of active attention. The difference, in so-called normal subjects, was determined to be about a tenth of a second. Far from constituting the grounds of a transcendental subjectivity, the word “apperception” here has only an empty redundant link with the same term as used by Kant or Leibniz.

Although there were major disagreements about why some contents and not others became the objects of attention (whether because of inhibition, will, interest, habit, etc.), there was widespread use of this generalized topographical plan. For example, a widely used variant in the 1890s located attention as the center of concentric circles of diminishing degrees of conscious awareness and

23. Wundt, *Grundzüge der physiologischen Psychologie*, pp. 85–87; Théodule Ribot articulated a related scheme of periphery and center which, derivative or not, was equally influential, in *The Psychology of Attention* (1889; Chicago: Open Court, 1896), pp. 21–22. See Kurt Danziger, “Wundt’s Theory of Behavior and Volition,” in R. W. Rieber, ed., *Wilhelm Wundt and the Making of a Scientific Psychology* (New York: Plenum, 1980), pp. 89–115: “Thus, he described the functioning of the dynamic principle in human behavior in terms of the concept of *apperception*, which is essentially the focalization of some content in consciousness. Wundt’s model of mental functioning is that of a field in which there is always a polarity between the central part (the *Blickpunkt*) and the periphery (the *Blickfeld*), that is, between the focal point and the rest of the field. This polarization is the product of the apperceptive process, which is a fundamental active principle that is responsible for the fact that all experience is structured. Apperception, however, was for Wundt the characteristic manifestation of volition. It was the dynamic principle that gave direction and structure both to experience and movement” (p. 104).

24. See, for example, the assertion that the categories of *near* and *distant* vision are inseparable from their particular deployment of the foveal and peripheral areas of the eye, in Jose Ortega y Gasset, *The Dehumanization of Art and Other Essays on Art, Culture, and Literature* (1925), trans. Helene Weyl (Princeton: Princeton University Press, 1968), pp. 109–113. This model of the field of vision is crucial to Ortega’s account of Western painting’s ineluctable move toward the subjective, toward an art not of objects as they are seen but of “the experience of seeing.”

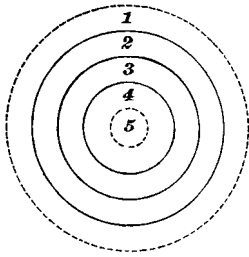

FIG. 33. Graphic representation of the field of consciousness. 1, the unconscious (physiological); 2, the subconscious; 3, diffused, vague consciousness; 4, active consciousness; 5, the focal point of attention.

Schematic representation of consciousness and its periphery, from Baldwin, Handbook of Psychology, 1891.

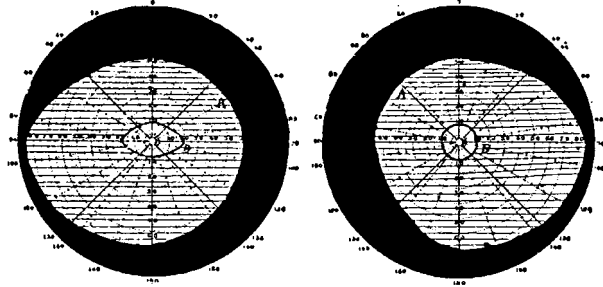
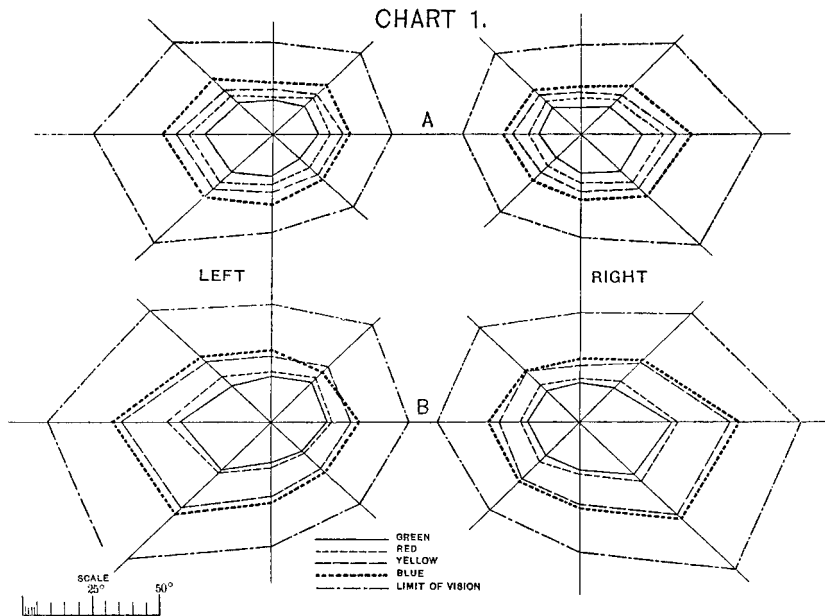

FIG. 1. — Champ visuel de Vel. A limite du champ visuel sans effort d'attention. B limite du champ visuel au moment d'un effort d'attention pour additionner des chiffres placés au point central du périmètre. L'expérience faite successivement sur les deux yeux donne des résultats analogues.

Diagram of contracted visual field due to weakness of attention, from Pierre Janet, Nevroses et idées fixes, 1898.



Range of color perception in relation to visual center and periphery, late 1890s. From American Journal of Psychology, January 1895.

perceptual focus. Others deployed a related kind of schema as a literal mapping of the structure of the visual field. Following the example of Charcot, Pierre Janet attempted to diagram and measure the effective extent of the visual field, which in his specific work was part of the determination of mental weakness or neurosis.²⁵ Some studies charted the varying range of color sensitivity, demonstrating that red and green were not perceptible by peripheral vision, unlike blue and yellow. This new knowledge, and this schema, were clearly deployed in techniques for externally managing perceptual experience; at the same time they indicate the collapse of models of a unifying homogeneous perception. What is at stake here is a model of subjective experience, located in many different places in the 1880s and 1890s, in which consciousness is not a seamless sphere where a world is fully self-present to a subject but rather a disjunct space in which contents move between zones of varying levels of clarity and awareness, vagueness and responsiveness.²⁶

One crucial feature of this model is the constantly changing content of the *Blickpunkt*, the movement of this content from focal point to the margins of awareness or the reverse. This so-called “topographical” model of the eye might seem to organize the visual field in terms of figure and ground, with a separation between focused center and peripheral background, but those distinctions had no permanence or stability. Perception was a process in which those terms were perpetually shifting into one another, in ceaseless reversals and displacements. Even though the foveal *Blickpunkt* coincided with an anatomical *center*, the cognitive modalities at stake here are part of larger modern processes of *decentering*. By the late 1890s, in the work of Charles Sherrington and others studying the nervous

25. Pierre Janet, *Névroses et idées fixes* (Paris: Félix Alcan, 1898), pp. 70–79.

26. A French translation of Wundt's *Grundzüge* appeared in 1886 as *Elements de psychologie physiologique*, trans. Elie Rouvier (Paris: Alcan, 1886), with *Blickfeld* and *Blickpunkt* rendered as “champ de regard” and “point de regard principal.” By the late 1880s, details of Wundt's specific schema had been discussed in general literary and cultural publications. See, for example, Alfred Fouillee, “La sensation et la pensée,” *Revue des Deux Mondes* 82 (July 15, 1887), p. 418: “Comparing the field of consciousness to the field of vision, M. Wundt designates perception as the entrance of any kind of representation, whether a sound or odor, into the ‘visual field of consciousness.’ He uses the term apperception for when this same representation enters the ‘visual focal point’ of consciousness, that is to say when attention seizes an object. According to him, the most fundamental activity of our thought consists in the power we have of leading a representation to this focal point and holding it there.” But already, in a work that was widely read throughout the 1870s, Hippolyte Taine had suggested many of these general features of subjective experience: “This is the constant state of our minds, a dominant image, in the full light, and extended around it, a constellation of fading images, growing more and more imperceptible; beyond these a milky way of images wholly invisible, of which we have no other consciousness than by the effect of their mass, that is to say by our general feelings of gaiety or sadness. Every image may pass through all the different states of light and dimness.” Taine, *On Intelligence* (1870), trans. T. D. Haye (New York: Holt and Williams, 1872), p. 169.

system, the periphery of the eye with its intensified ability to detect movement was understood as a powerful remnant of our biologically remote past, with which we retained the capacity to initiate action instantly, against either potential predator or prey, implying a mixed and simultaneous distribution of attentiveness across this divided visual field, and further rendering a figure/ground distinction irrelevant. As William James and others agreed, it was no longer a question of a succession of immobile states or views with a fixed relation between center and periphery, but rather of the primacy of *transitive* states in which the shifting fringes of perception were constitutive features of psychic “reality.”²⁷

The problem of optical center and periphery, of the dispersed functioning of sensory response, has been part of the ongoing modernization of perception since the nineteenth century. Two of the most pervasive nineteenth-century constructions of optical experience define some of the terms of these new conditions. The first of these was the architectural model of panorama painting, in which the 360-degree image stood for a permanent activation of the optical periphery at the expense of a stable center of focused attentiveness. Then consider the stereoscope, which posed a rival (or complementary) model of visual consumption. Its decisive *exclusion* of the periphery (especially in the Holmes viewer) presented an illusory three-dimensional image that barely extended beyond the range of central foveal clarity, so that, within the optical model I am outlining, it produced an image which, in its hypertangibility, was all figure with no ground, no periphery. What is lost in both panorama and stereoscope is the possibility not only of a classical figure/ground relationship, but also of consistent and coherent relations of distance between image and observer.²⁸ These features were noted by the German critic and sculptor Adolf Hildebrand, who deplored both of them (and their popularity) in his defense of rationalizable spatial values and rejection of a physiologically based vision.²⁹

27. See the discussion of James’s theory of “transitive parts” in Aron Gurwitsch, *Studies in Phenomenology and Psychology* (Evanston: Northwestern University Press, 1966), pp. 301–331.

28. Wundt, drawing on remarks by the Spanish neurologist Ramon y Cajal, poses an opposition between the “panoramic” and “stereoscopic” capacities of the human eye, in *Principles of Physiological Psychology* (1874), trans. Edward Bradford Titchener (New York: Macmillan, 1904), vol. 1, p. 233.

29. See Adolf Hildebrand, “The Problem of Form in the Fine Arts” (1893), in Harry Mallgrave and Eleftherios Ikononou, eds., *Empathy, Form, and Space: Problems in German Aesthetics, 1873–1893* (Santa Monica: Getty Center for the History of Art and the Humanities, 1994), p. 242: “The sense of reality that the panorama seeks to evoke presumes an insensitivity and coarseness of observation, a lack of any refined functional feeling on the part of the viewer. . . . Today’s refined panorama, however, supports the coarseness of sense by a perverse sensation and a falsified feeling of reality in precisely the same way that wax figures do!”

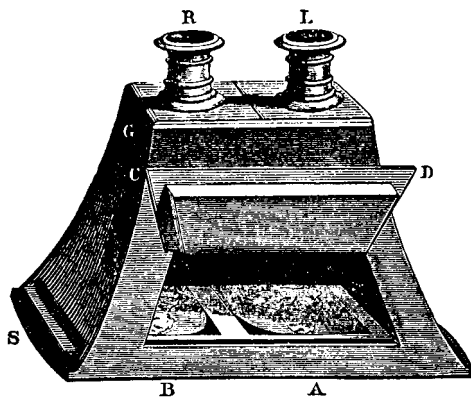
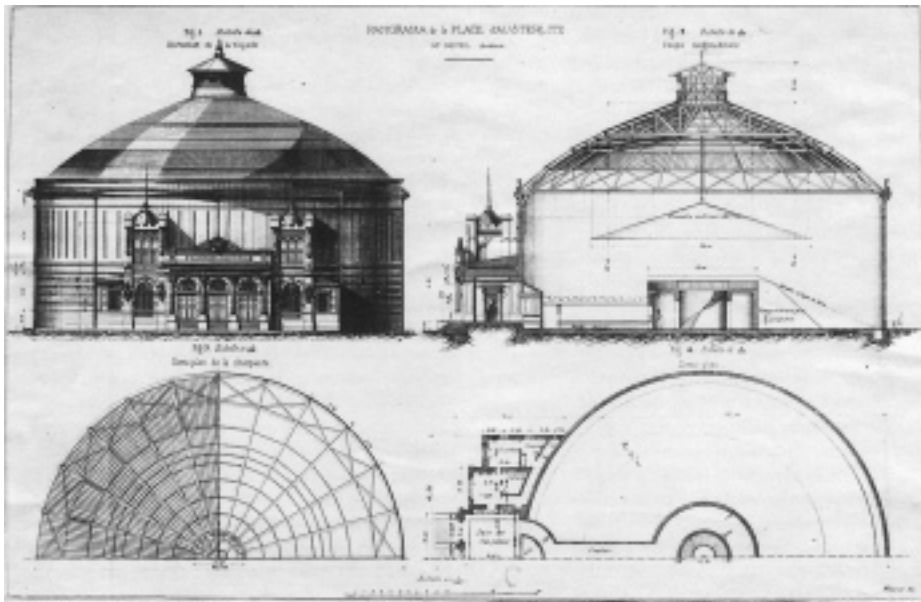

Stereoscope and panorama, mid-nineteenth century.

Part of the strangeness of Cézanne's late work may be due, as some critics have suggested, to an attempt to grasp peripheral retinal sensation simultaneously and with the same immediacy and intensity as the central or foveal region of the eye.³⁰ It would not have been a question of aspiring to a unified homogeneous field of vision but rather to having the fixed eye apprehend many disconnected areas of the visual field at once, instead of repressing the periphery as most of us do almost all the time. In a sense it would be an effort to achieve what has been defined as empirically and subjectively impossible: for example in Michael Polanyi's assertion that "subsidiary awareness and focal awareness are mutually exclusive."³¹ Paradoxically, a system based on a distinction between a center and periphery effectively dissolved the possibility of a stable central point around which the disparate contents of this field could be coherently organized. This may have been part of what Rilke meant in describing Cézanne's practice as a continual "beginning at a new center."³² The various codes which for several hundred years had territorialized the field of vision are discarded, not to uncover a natural "savage" vision, but to allow the free play of newly constructed *centrifugal* forces within the spaces of perception. Thus, much of his work from the mid-1890s on is a radical rethinking of the nature of *synthesis*—synthesis in the sense of the rhythmic coexistence of radically heterogeneous and temporally dispersed elements. Cézanne's work poses the idea of an attentive fixation, a subjective immobilization that, instead of holding together the contents of the perceived world, seeks to enter into its ceaseless movements of destabilization. The partial and ambivalent attempts in Manet and Seurat at imposing a binding stasis are no longer possible in the system of Cézanne's late work. For here we encounter an attentiveness that, when sustained beyond the verge of possibility, crosses over not into reverie or dissociation but into a more intensive re-creation of a subjective interface with the world. Because attention for Cézanne did not attempt to hold onto the presence of an identical, recognizable world, its limits and excesses disclosed not loss and absence but the understanding that "every object, every thing must see its own

30. See the rich discussion of these issues in relation to the paintings of Pierre Bonnard in John Elderfield, "Seeing Bonnard," in Sarah Whitfield, ed., *Bonnard* (New York: Museum of Modern Art, 1998), pp. 33–52.

31. Michael Polanyi, *Personal Knowledge: Towards a Post-critical Philosophy* (Chicago: University of Chicago Press, 1958), p. 56. Polanyi emphasizes the subjective importance of "the personal commitment which is involved in all acts of intelligence by which we integrate some things subsidiarily to the centre of our focal attention" (p. 61).

32. Rainer Maria Rilke, *Letters on Cézanne*, trans. Joel Agee (New York: Fromm, 1985), p. 36.

identity swallowed up in difference,” and that vision itself was “a veritable theater of metamorphoses and permutations.”³³

There may have been a period in the late 1880s (or at least we can provisionally imagine such a time) when Cézanne might have believed that a relentless attentiveness to the data of the senses would secure the contents of a visual field into a “spatial unity” or into an objective armature of relations. But what he discovered, perhaps slowly, haltingly, was that this kind of fanatical attention did not disclose either some primal structure to the world or a realm of essences; nor did it lead him to an art with the solidity of Rubens or Poussin.³⁴ Rather it exposed a dissolution of unity, a destabilization of objects. It opened up onto flux, dispersion, and even as attention seemed to join the eye and body to the world it also undid the very immediacy of the world and displaced the body into a stream of change, of time.

If Cézanne were going to reexamine the composition of the visual world, he would not have begun by glancing or sweeping the eye back and forth over the visual field. One learns nothing new that way; it yields a world already known through habit and familiarity. The scanning of our active eye movements, either voluntary or involuntary, is generated by expectations already established by habitual processing of known cues within a given environment. Only by patiently looking in a fixed way at local areas of the field does one begin to see its unknown texture, its strangeness, the unfathomable relations of one part of it to another, the uncertainty of how these local elements interact as a dynamic field.³⁵ When one deliberately moves one’s eye slightly from one fixed position to another, the shift of an object or area out of the center of vision even to the inner edge of the periphery transforms it: its color modulates to something less distinct, it loses detail but

33. Gilles Deleuze, *Difference and Repetition*, trans. Paul Patton (New York: Columbia University Press, 1994), p. 56.

34. See the account of the “Cézannean moment” in Thierry de Duve, *Pictorial Nominalism: On Marcel Duchamp’s Passage from Painting to the Readymade*, trans. Dana Polan (Minneapolis: University of Minnesota Press, 1991), pp. 76–78: “It is because Cézanne’s desire was fundamentally conservative that his doubts had the innovational consequences that we well know. . . . At each moment of painting, Cézanne had to come to grips with two questions that for him were inseparable: What is the world, if my vision, modeled by that of my artistic predecessors, is no longer certain of its own reality? And who am I, if my image in the mirror vacillates, unsure of its own objectivity?”

35. “The unconscious movements of the eye are not merely *aids* to clearer vision but a *sine qua non* of vision. When the subject’s gaze remained really fixed on a stationary object (by means of a mechanical device) his vision went haywire, the image of the object disintegrated and disappeared—then reappeared after a while but in distorted shape or in fragments. Static vision does not exist; there is no seeing without exploring.” Arthur Koestler, *The Act of Creation*, rev. ed. (New York: Macmillan, 1969), p. 158.

more importantly becomes something other than what it had just been, and in a new relation to what now occupies the *Blickpunkt*. Perceptual constancy is a phantom, and the world thus seen is no longer identical to itself. It becomes, as Lucretius long ago understood, an infinite cascade of self-differentiation.

Paul Valéry, writing in the early 1890s, was acutely aware of related effects of a fixed contemplation, and his problem like Cézanne's was how to reconcile that intuition of "the fragility of the world" with the task of aesthetic *construction*. This was one of the themes of his remarkable essay on the method of Leonardo. The dilemma of an attentive perception for Valéry was the following: "When we look at [objects] fixedly, they change if we think of them, and if we do not think of them, we fall into a lasting torpor, of somewhat the same nature as a tranquil dream." Here we have a sense not just of the continuity between attention and reverie, but of their reversibility, of the back and forth movement that is possible. But when concentrating fixedly, he recounts, "the objects about me are as *active* as the flame of the lamp. The armchair decays in its place, the table asserts itself so fast that it is motionless, and the curtains flow endlessly away. The result is an infinite complexity. To regain control of ourselves in the midst of the moving bodies, the circulation of their contours, the jumble of knots, the paths, the falls, the whirlpools, the confusion of velocities, we must have recourse to our grand capacity for forgetting."³⁶ For both Valéry and Cézanne, it was only having attained an awareness of this unstable complexity that the mind could then begin to construct concepts and to create.³⁷ At the same time, the task of construction, for each of them, required a radical rethinking of the problem of substance.

In much recent theoretical writing, the idea of the fixed (and usually monocular) eye has been posed as a formative element of classical systems of representation, functioning to arrest duration and change in order to achieve a conceptual mastery of phenomena. However, I am suggesting the problematic and contrary notion that the fixed, immobile eye (at least as static as physiological conditions

36. Paul Valéry, *The Collected Works of Paul Valéry*, vol. 8, trans. Malcolm Cowley (Princeton: Princeton University Press, 1972), pp. 25–26.

37. See the discussion of Valéry and perception in Geoffrey Hartman, *The Unmediated Vision* (New York: Harcourt, Brace and World, 1966), pp. 97–124. In this important book, Hartman argues that "the perplexity of the eyes" is part of "a deeper and metaphysical perplexity," and Valéry is one of the figures in which he locates the outlines of "an imageless vision": "Valéry shares in the general crisis of the aesthetic consciousness which would suspend all relational knowledge of things in order to know the indefinite moment between possibility and act, but knows only the dispossession of a mind for which no visible form is visible enough" (p. 112).

ever allow) is what annihilates the seeming “naturalness” of the world and discloses the provisional and fluid nature of visual experience, whereas the mobile glancing eye is what preserves the preconstructed character of the world. The latter is the eye that habitually, familiarly caresses objects, extracting only previously established relations from among them. Once the eye stops moving, a potentially volatile situation arises: after a relatively brief period of time the immobile eye triggers a ferment of activity—it is the doorway to both trance and to perceptual disintegration.³⁸ Louis Sass has traced many instances of the fixed “truth-taking stare” and its accompanying “perceptual uncanniness” in early twentieth-century modernism: a stare that is “rigid and fixed—passive, in this sense; yet it bores through, breaks up, or withers its object, dissolving the physiognomy of the everyday world.”³⁹

Most discussions of long fixation tend to talk about it only in relation to a notion of a normative vision, for example Nelson Goodman who characterizes the fixed eye as “blind.”⁴⁰ Others analyze it in terms of its “distortions,” as if it were perfectly obvious what was implied by the idea of an undistorted original perception. At the same time, when the specific effects (or distortions) of fixed vision are discussed, they are usually treated as if they were stable objects that exist in some accessible state available for objective comparisons and evaluation. Missing from discussions by Wolfgang Kohler and others is the way long fixation sets the world in motion, the way parts of the visual field begin vibrating and oscillating.⁴¹ Fixed vision can produce such chromatic instability, a pushing forward of distant planes amid an overall web of dynamic perturbations, that any discussion of whether a rectangle appears distorted is irrelevant. There arises an irresolvable contradiction between the aim of stabilizing the world to look at it analytically and the experience of a physiological apparatus incapable of such stability.

38. See an attempt to evaluate the capacities of the moving eye in terms of the dubious notion of an objective standard of “truthfulness,” in E. H. Gombrich, “Standards of Truth: The Arrested Image and the Moving Eye,” *Critical Inquiry* 7, no. 2 (Winter 1980), pp. 237–273.

39. Louis A. Sass, *Madness and Modernism: Insanity in the Light of Modern Art, Literature, and Thought* (New York: Basic Books, 1992), p. 66.

40. Goodman, committed to the notion of a “normal” vision, writes that “experiment has shown that the eye cannot see normally without moving relative to what it sees; apparently scanning is necessary for normal vision.” Nelson Goodman, *Languages of Art* (Indianapolis: Bobbs-Merrill, 1968), pp. 12–13.

41. See the important discussion of Cezanne and long fixation in Anton Ehrenzweig, *The Psychoanalysis of Artistic Vision and Hearing* (New York: Braziller, 1965), pp. 193–215: “‘Prolonged fixation’ proves the best means to destroy the surface gestalt and bring up the repressed perceptions hidden underneath.” Ehrenzweig also contends that the activation of peripheral vision in Cezanne allows the emergence of “diffuse gestalt-free modes of perception.”

The effects of fixed vision, however, ought not to be used as a way of explaining the appearance of Cézanne's work, as some have done. This would imply that Cézanne's so-called distortions are the result of the artist trying to faithfully portray his subjective optical impressions (or the even more banal proposal that his late work is the product of deteriorating vision or cataracts as he got older, and that he represented the effects of these deficiencies). These approaches place Cézanne within a familiar problematic of "perceptualism"—the idea that his paintings in varying degrees involve a transcription of the world "as it appears" to him. Nor is Cézanne putting together a mosaic of individual views by the fixed eye, patching them together into a single, integrated surface. Rather, various experiences with optical fixation and immobilization revealed to him the inadequacy of conventional pictorial practices for the representation of a world that did not, in the deepest sense, possess a premade integrity, and provided him the understanding that the world can only be engaged as a process of becoming. At issue in Cézanne's sensitivity to the physiological conditions of vision is not that he discovered in them a "natural" modality of perception but that he sought ways to exceed those limitations and to make the eye into a new kind of organ. It was hardly an effort to deny the body, to create a pure disembodied vision, but to discover new cognitive and physical relations to the sensory world.

Cézanne's declaration that there are no straight lines in nature is a renunciation of what Nietzsche identified as the phenomenal world: "the adapted world which we feel to be real. The 'reality' lies in the continual recurrence of identical, familiar, related things in their logicized character, in the belief that here we are able to reckon and calculate." Both Cézanne and Nietzsche refuse this process by which "the fuzziness and chaos of the sense impressions are, as it were, logicized."⁴² In Nietzsche we learn that the antithesis of this phenomenal world is "the formless unformulable world of the chaos of sensations"; in Cézanne we engage a motor and sensory attentiveness to the continual emergence and disintegration of constellations of relationships of which the self was a constituent element.



Within the institutional accumulation of knowledge about a human subject, the more attention was shown to be ambiguous and problematic, the more it

42. One of Nietzsche's targets here is likely Helmholtz's influential description of the real as the consistent and habitual recurrence of the identical. See his early critique of Helmholtz's doctrine of "unconscious inferences" in *Philosophy and Truth*, ed. Daniel Breazeale (Atlantic Highlands, N.J.: Humanities Press, 1979), pp. 48–49.

became necessary to create experimental conditions in which a perceiver's attentive behavior had a minimum of ambiguity. Some of these conditions involved the production of other kinds of "fixed" vision, amid the increasing awareness of the "transitive" and unstable nature of perception. Modern psychology, as it emerged in the late nineteenth century, "posed as a way of dealing with the embarrassment of not having absolute certainty; for it suggested how to incorporate the vagaries and unpredictability of 'subjectivity' into a set of constants."⁴³ The work of Fechner on "just noticeable differences" or the early work of Wundt had relied to a high degree on subjective evidence, or even on "data" that was acquired through wholly introspective procedures. How then could conditions be controlled so that a subject's perceptual experiences could be convincingly quantified? If researchers were concerned to determine the range of subjective response to a specific and delimited group of stimuli, how could these stimuli be perceptually isolated, and more importantly how could their exposure to a subject be *temporally* controlled?

The tachistoscope, developed during the early to mid-1880s, was a product of the search for an elemental unit of attentive behavior, which was believed necessary if various forms of perceptual and cognitive activity were to be empirically observed and evaluated.⁴⁴ The tachistoscope is "an instrument for the presentation of visual stimuli, such as a picture, a word, a group of symbols, the duration of each stimulus being extremely short. The onset and disappearance of the whole field is practically instantaneous."⁴⁵ Of course this ideal of instantaneity was a chimaera, as many researchers subsequently demonstrated.⁴⁶ Nonetheless, the tachistoscope presumed to make possible an examination of specific physiological

43. Didier Deleule, "The Living Machine: Psychology as Organology," in Jonathan Crary and Sanford Kwinter, eds., *Incorporations* (New York: Zone Books, 1992), p. 210.

44. The tachistoscope is discussed in the context of the technological reconfiguration of reading in the late nineteenth century in Friedrich Kittler, *Discourse Networks 1800/1900*, trans. Michael Metteer (Stanford: Stanford University Press, 1990), pp. 222–223: "The helplessness of the experimental subjects before the tachistoscope ensures that all 'processes' whose 'uncommonly complex embodiment' is reading . . . will yield only measurable results."

45. Howard C. Warren, ed., *Dictionary of Psychology* (Boston: Houghton Mifflin, 1934), p. 271. See also the discussion of the tachistoscope as crucial to an "empiricist" account of attention in Alexandre Bal, *Attention et ses maladies* (Paris: Presses universitaires de France, 1966), pp. 14–18.

46. See, for example, the valuable discussion of tachistoscopic and other kinds of brief exposure experimentation in Ulric Neisser, *Cognitive Psychology* (New York: Appleton-Century-Crofts, 1967), pp. 15–28. Neisser shows that the original uses of the tachistoscope were based on a naive realism that presupposed "(1) that the subject's visual experience directly mirrors the stimulus pattern; (2) that his visual experience begins when the pattern is first exposed and terminates when it is turned off." These assumptions are wrong for many reasons, he writes, but particularly because they ignore the existence of "transient iconic memory" which allows a subject to continue to "read" visual information even after

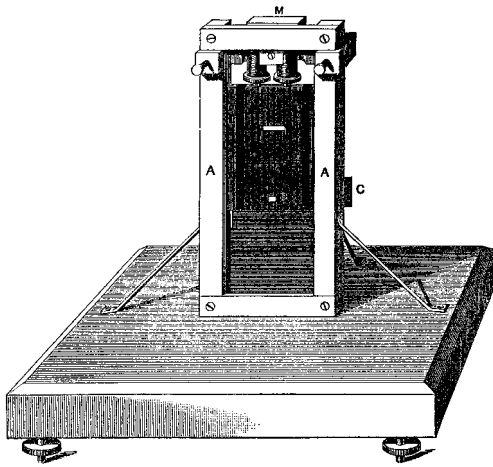

Tachistoscope, late 1880s.

capacities from which time was effectively excluded as a variable. It was founded, at least implicitly, on the understanding that the only “presences” possible for a human perceiver will necessarily be mechanically produced. It provided the semblance, or the fantasy, of a discrete, quantifiable perception detached from the lived dynamics of the body, just as Hermann Ebbinghaus was at the same time attempting to quantify the operations of memory on the basis of meaningless syllables or abstract verbal units.⁴⁷ Friedrich Kittler insists that one of the crucial elements of Ebbinghaus’s project was the assumption that “pure nonsense reveals specific aspects of attention that hermeneutics could not even conceive.”⁴⁸

Tachistoscopic data was derived from a technological arrangement that immobilized the body and the eye: that is, the speed of its mechanical shutter was far faster than the muscular capabilities of the eye. It was a device designed with one overriding requirement: that it allow only a single glance (though this obvi-

a stimulus is no longer present. The idea of an instantaneous perception was challenged decisively by George Sperling in 1960, who showed that for a perception to have any psychological significance it must be *processed* after the stimulus disappears, implying that perception is not given but must be constructed. Sperling, “The Information Available in Brief Visual Presentations,” *Psychological Monographs* 74, no. 498 (1960), pp. 1–29.

47. See Hermann Ebbinghaus, *Memory: A Contribution to Experimental Psychology* (1885), trans. Henry Ruger and Clara Bussenius (New York: Dover, 1964). He stresses the importance of the “very lack of meaning” and “homogeneity” (pp. 22–23) of the material used for memory research, and openly acknowledges that he is doing precisely what later critics deplored: removing memory from its conditions of operation in everyday life. See the assessment of this work in Leo Postman, “Hermann Ebbinghaus,” *American Psychologist* 23 (1968), pp. 149–157.

48. Kittler, *Discourse Networks*, p. 209.

ously was a highly problematic notion) and that the eyes not have time to shift their point of focus during the exposure, that is, not have time to move or have two different glances at the same field. As early as 1906, photographs were made of eyes observing tachistoscope exposures of shorter than a hundredth of a second, and in fact no meaningful shifts of fixation could be detected. It is one of many examples of how, within the context of technological modernization, faster mechanical speeds are reciprocally related to new bodily forms of stasis.⁴⁹ Attention, as it became a core problem in the late nineteenth century, was also in most cases conceptualized as a physical modality of (relative) immobility within a life-world increasingly shaped by experiences of speed and mobility.

The tachistoscope, with its high-speed shutter, in practical terms achieved what it set out to do: it could mechanically produce conditions under which the eye behaved as if *immobile* and would perceive stimuli “in an instant.” It presupposed the concept of “inextensive sensations.” In this sense it produced its own highly controlled form of “fixed vision.” Researchers sought, for example, to determine how many individual elements an attentive subject was capable of apprehending without moving the eye from point to point or without performing simple mental operations (such as addition or other kinds of calculation). This was referred to as the “range of attention.” Experimentation, including that of Wundt, with this first generation of laboratory equipment showed, contrary to associationist assumptions, that one could attend to several things simultaneously.⁵⁰ However, it was not a question of perceiving a Gestalt composed out of a handful of separate elements. Paradoxically, in an experience from which time had been drained away, consciousness could still have a basic intuition of plurality.

49. This thematic of the reciprocity of speed and immobility within modernity runs throughout the work of Paul Virilio. See, for example, his *Speed and Politics*, trans. Mark Polizzotti (New York: Semiotexte, 1986).

50. Wundt and many after him attempted to determine the limits of what could be attended to simultaneously; that is, how many things or processes could occupy that center of attentive clarity. The tachistoscope quickly became a major part of research on questions of how a number of individual elements could be apprehended simultaneously. It was often a problem of numerical discrimination that yielded the same relatively imprecise and unsurprising answers: most people had the ability to immediately intuit a group of five units or objects (that is, without counting them) a smaller percentage could regularly grasp a group of six, and almost no one could see a grouping of seven in a single act of attention. See, for example, W. Stanley Jevons, “The Power of Numerical Discrimination,” *Nature*, February 9, 1871, pp. 281–282. William James was concerned with the issue of how many processes or activities a perceiver could attend to simultaneously: his answer was “not easily more than one, unless the processes are very habitual.” James, *Principles of Psychology* (1890; New York: Dover, 1950), vol. 1, p. 409. For a more recent assessment of this problem, see G. M. Miller, “The Magic Number Seven, Plus or Minus Two: Some Limits on Our Capacity for Information Processing,” *Psychological Review* 63 (1956), pp. 81–97.

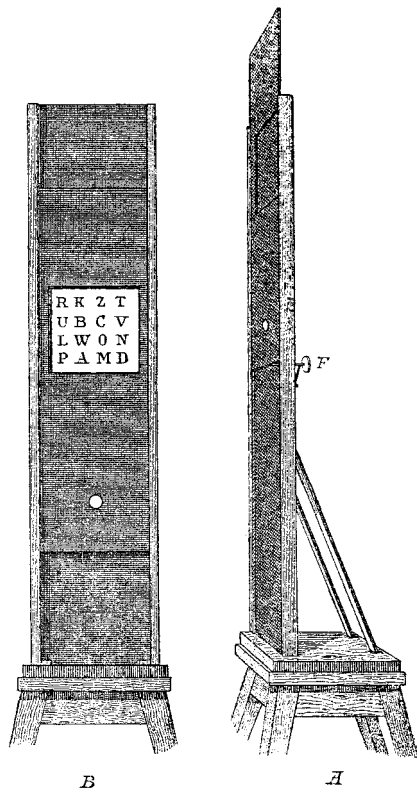

Laboratory device for instantaneous visual displays, 1880s.

The tachistoscope became paradigmatic of an ideal of experimental control. By the turn of the century dozens of other laboratory apparatuses similarly generated data that allowed a quantifiable image of the psychophysiological capacities of the subject. At the same time the tachistoscope was a model of ways in which external stimuli (or experience) could be produced for that subject. The subject of tachistoscope experiments was positioned as an *expectant* spectator before a screen covered with a mechanical “curtain.” It was essential for that subject to attentively anticipate the brief opening of this curtain, which would expose whatever lay on the screen. His or her eyes were directed to a fixation point (whose spatial location was virtually identical with the plane of the as yet unexposed screen) so that the eyes of the subject were focused and converged in advance, again eliminating the temporality of optical movement and adjustment. This “pre-exposure” field was also carefully arranged to have the same brightness as the exposure field so that the eyes would not have to adapt to any change in lighting

conditions. Additional requirements were that the action of the shutter be imperceptible, so that the eye would not inadvertently follow it, and that the operation of the device be completely silent. Paradoxically, these conditions all aimed at preserving the continuity and sameness of the observer's subjective experience even as the brief exposure on the screen effectively disrupted that continuous identity. The tachistoscope was part of a broad-ranging project to acquire knowledge that would allow a rationalization of a perceiver and the management of attentiveness, but it did so through a fragmentation of vision perhaps even more thorough than anything in early forms of cinema and high-speed photography. This apparatus is an instance of the production of "shock" as an integral part of the institutional determination of normative human behavior and response.⁵¹ The break or the interruption of vision becomes the primary element within perceptual experience, rather than a visual continuum that maintains the cohesiveness of the world. For it was only within the "purity" of the instantaneous break that the vagaries and uncertainties of "normal" vision could be eliminated.⁵² Like other new technologies that took shape within this experimental milieu, it posed at least the possibility of pure sensation *without* perception.

It should be noted that the tachistoscope was developed in close proximity to Muybridge's mechanically operated shutters which he used for instantaneous photography in the late 1870s. The double-acting slide on the Muybridge device has numerous operational and structural parallels with the standard gravity tachistoscope of the late 1880s, and a purely instrumental history of technological invention could certainly demonstrate crucial linkages between these and other related devices. But more importantly both apparatuses introduced new mechanical speeds into the domain of human perception. Muybridge's machines served, for the most part, to reconstruct appearances through the production of *consecutive* images. The tachistoscope, on the contrary, was used to present nonconsecutive visual stimuli that could not be processed over time. By the turn of the century, paralleling the development of certain cinematic techniques, *projection* tachistoscopes were deployed in some psychology laboratories. In their use of ultrafast

51. See the discussion of Albert Londe's photographic work in the 1880s for Charcot, in which the shock and surprise of the instantaneous photographic *flash* was used in the mastery of "hysterical" patients, in Ulrich Baer, "Photography and Hysteria: Toward a Poetics of the Flash," *Yale Journal of Criticism* 7, no. 1 (1994), pp. 41–77.

52. James J. Gibson defends the problematic notion of a "normal" vision in relation to the tachistoscope: "Is the tachistoscope an achievement? It seems to me to be a calamity. Far from reducing visual experience to its simplest form, it prevents the visual system from operating normally." Gibson, "Conclusions from a Century of Research on Sense Perception," in Sigmund Koch and David E. Leary, eds., *A Century of Psychology as Science* (New York: McGraw-Hill, 1985), pp. 224–230.

“cutting,” such experiments certainly prefigure the effects of high-speed montage in cinema, where perceptual thresholds are approached and the question of subliminal images becomes important.

One of the early applications of the tachistoscope was in the work of James McKeen Cattell, a major figure in late nineteenth- and early twentieth-century American psychology.⁵³ The origins of Cattell’s enormously influential work on attention span and reaction time can be traced to his apprenticeship under Wundt in Leipzig in the mid-1880s. Back in North America at Columbia University, Cattell, like many psychologists of his generation, moved away from Wundt’s concern with determining the features and functioning of a generalized “consciousness” to a preoccupation with the detailed psychometrics of individual performance and behavior. The origins of a vast array of “mental tests” used throughout the twentieth century go back to the work of Cattell and others in the 1890s. At the same time he stood for a rejection of many of the assumptions of psychophysics, which had sought to correlate internal mental states with external physical stimuli. He prefigures aspects of early twentieth-century behaviorism in this abandonment of interest in any internal or introspective experience in favor of data that resulted from objective and externally controlled observation. Far more explicitly than psychologists of the preceding generation, Cattell succinctly characterized the aims of his work as “the application of systematized knowledge to the control of human nature.”⁵⁴

Cattell is a participant in a much larger acquisition of knowledge about perception that would permit an accommodation of subjective life to machinic operations, speeds, and temporalities, even as the conditions of its own research were imposing comparable machine speeds and movements on subjects. It was a quest for constants and certainties amid the same perceptual instabilities that Cézanne and others were exploring. As part of a “psychology of human capacities,” Cattell sought to determine and quantify the specific factors that could modify the *performance* of an individual subject.⁵⁵ The tachistoscope and other chronometric devices were crucial for him in quantifying various types of performative

53. Cattell describes his device in “The Inertia of the Eye and Brain,” *Brain* 8 (October 1885), pp. 295–312. The name “tachistoscope” was first suggested by the physiologist A. W. Volkmann in 1859, who had been a collaborator of Fechner.

54. James McKeen Cattell, “The Conceptions and Methods of Psychology,” *Popular Science Monthly* 66 (1904), pp. 176–86; reprinted in A. T. Poffenberger, ed., *James McKeen Cattell: A Man of Science*, 2 vols. (Lancaster, Pa.: Science Press, 1947), vol. 2, pp. 197–207.

55. This characterization is from E. G. Boring, *A History of Experimental Psychology*, 2d ed. (New York: Appleton-Century-Crofts, 1950), p. 539.

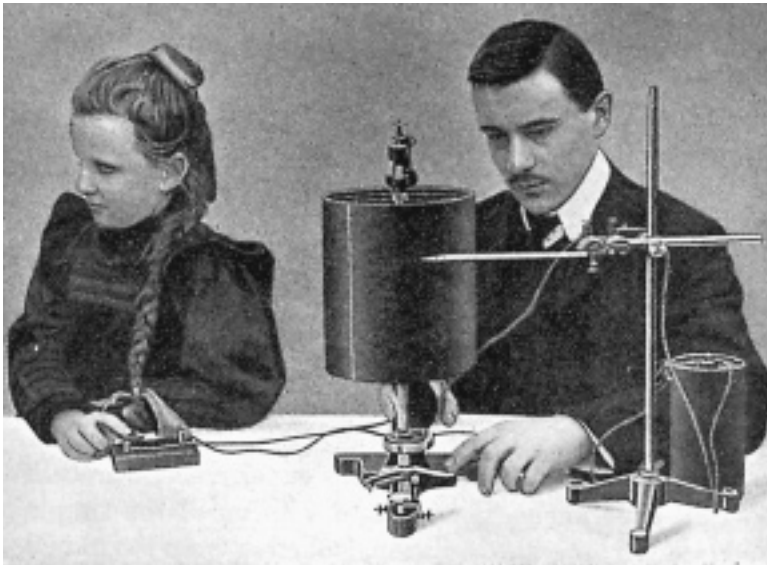

Reaction time experiment with acoustical stimulus, late 1890s.

behavior.⁵⁶ Reaction time was perhaps the single most important area where he did groundbreaking work with these devices, which quickly became standard laboratory tools. A typical question was how it might be possible to increase the speed with which an observer could recognize certain objects in a visual field. But even by the end of the 1880s Cattell's goals had gone far beyond the measurement of "simple" reaction time, or of discrimination and association; he sought to measure more significant components of human subjectivity, such as "how long it takes to form a judgment or opinion."⁵⁷ Experiments disclosed huge amounts of information: for example, how reaction time was diminished in relation to increases in the intensity of a stimulus, say through greater luminosity or loud-

56. Cattell's experiments "focus not upon the general characteristics of distinct mental functions across a range of individuals, with a view to establishing some general law, but upon the specific combinations of these distinct functions in particular individuals, with a view to establishing the parameters of individual difference. . . . The test allows two complementary alliances to be formed—firstly with the technological operations associated with an administrative schema of the discrimination, classification, and distribution of individuals with a view to ordering the population, and secondly with those statistical techniques in which the variations between individual measures is the basis of their mathematical treatment." Nikolas Rose, "The Psychological Complex: Mental Measurement and Social Administration," *Ideology and Consciousness* 5 (Spring 1979), pp. 49–50.

57. James McKeen Cattell, "Experiments on the Association of Ideas," *Mind* 12 (1887), p. 74.

ness.⁵⁸ Consequently, knowledge was accumulated about how to achieve greater rates of productivity and efficiency from human subjects in situations where response time was a factor. At the same time, normative models of reaction times were established in relation to specific pathological impairments of attention and response.⁵⁹

But the importance of reaction time clearly exceeds its place within the rationalization of labor. In a more significant way, it was a sign of a fundamental repositioning of a perceiver in a relation of *subjection* to an objective world newly decomposed into autonomous and abstract stimuli.⁶⁰ It describes a generalized attentive expectancy and kinetic adaptation to machine speeds and rhythms that differed dramatically from those of the body. This socially produced vigilant attentiveness and motor readiness were compatible not just with then-new patterns of production and spectacular consumption. These patterns were especially developed through the rise of the automobile (and the prosthetic relations it entailed) and persist intact, though more intensified, in contemporary digital culture where the functioning of a machinic interface of body and computer keyboard incarnates a related temporal shaping of everyday life. In most cases, using a computer produces a psychic field of expectant attentiveness, within which one inevitably trains oneself to maximize the speed of response to specific commands and functions and in fact to derive at least some satisfaction from these habitual operations of mechanical facility. Thus the interest in reaction time was one of the consequences, within specific institutional bodies of knowledge and disciplinary practices, of that epistemic shift in the nineteenth century to theories of subjective vision and related physiological paradigms.

One physiological discovery in particular was to have an enormous impact on the subsequent empirical study of subjective experience: Helmholtz's

58. See, for example, Hiram M. Stanley, "Attention as Intensifying Sensation," *Psychological Review* 2, no. 1 (1895), pp. 53–57.

59. See, for example, Charles Féré, "L'énergie et la vitesse des mouvements volontaires," *Revue philosophique* 26 (July–December 1889), pp. 37–68, where reaction time is studied in cases of hysteria, epilepsy, and somnambulism.

60. Scientific research founded on Spencerian racial typologies determined "empirically" that non-Caucasians, especially "Africans and Indians," had the fastest reaction times: "It is the lower not the higher man who is more responsive to stimuli related to secondary reflex action, and men, in proportion to their intellectuality, tend less and less to quickness of response in the automatic sphere. Reflective men are the slower beings . . . intellectuality has been gained at the expense of automatic capacity." P. Meade Bache, "Reaction Time with Reference to Race," *Psychological Review* 2, no. 5 (September 1895), pp. 475–486.

measurement of the speed of nerve transmission in 1850.⁶¹ Prior to midcentury it was generally assumed that the time it took a stimulus to travel along nerves to the brain was so infinitely small as to be unmeasurable, and, more importantly, it was believed that the onset of a stimulus and a subject's experience of it were effectively *simultaneous*. Helmholtz's calculation of how long it took electricity to move along the human nervous system astonished people by showing how *slow* it was: about ninety feet per second. It was a statistic that heightened a sense of a disjunction between perception and its object, as well as suggesting startling possibilities of intervening in that gap between stimulus and response and of redefining a subject in terms of this new experiential domain of "reaction time." It made clear that it was no longer possible to think in terms of the instantaneity or unproblematic presentness of vision.

At first, reaction time was assumed to be a measurement of the interval between the inception of a stimulus (whether visual, auditory, or tactile) and the motor response of an organism. That is, researchers believed they were quantifying the time it took to recognize an external signal and the time it took to organize a response to it. The epistemological consequences stemming from Helmholtz's discovery included the realization that the present world as we experience it is in fact that world as it was a small fraction of a second earlier—that the apparent present is actually the past.⁶² Even the tachistoscope, as it sought to stabilize what Wundt called a "present state" of perception, was in fact being deployed within a temporally extended physiological set of events.

My discussion of these problems in nineteenth-century studies of perception is linked to the larger epistemological status of the particular sciences in question, whether biology, physiology, or psychology. Foucault's argument about the significance of biology and the volatile problem of "life" in the nineteenth century is of particular importance here: the essence of human life ceased to be something representable in the tabular space of classical representation but became understood in terms of its existence in time, of functions and energies that unfolded and developed outside of the immediacy of classical visibility. "Life becomes a fundamental force, and one that is opposed to being in the same way as movement

61. On this discovery see Kathryn M. Olesko and Frederic L. Holmes, "Experiment, Quantification and Discovery: Helmholtz's Early Physiological Researches 1843–1850," in David Cahan, ed., *Hermann von Helmholtz and the Foundations of Nineteenth Century Science* (Berkeley: University of California Press, 1993), pp. 50–108.

62. See the discussion in Stephen Kern, *The Culture of Time and Space, 1880–1918* (Cambridge: Harvard University Press, 1983), pp. 82–84.

to immobility, as time to space. . . . The experience of life is thus posited as the most general law of beings, the revelation of that primitive force on the basis of which they are: it functions as an untamed ontology."⁶³ But if, in the epistemic terms of Foucault's argument, being is supplanted by becoming in the nineteenth century, the new problem for the quantitative sciences was how to formalize objects of study that presented themselves in terms of development, change, growth, or decay. Clearly it was not a question of science denying the temporality of its objects but rather of rendering that time into elements susceptible to various forms of control and rationalization (though not always mathematical ones).⁶⁴ Attention as an object of knowledge involved the recognition that perception was essentially temporal and unstable but was also, if studied resolutely enough, capable of management and relative stabilization (as the example of the tachistoscope demonstrated).

The notion of the reflex arc, as it was articulated in the late nineteenth century, is one of the many ways in which the sciences attempted their formalization of human life. Paradoxically the hypothesis of the reflex was given additional confirmation by both the discovery of the slow speed of nerve transmission and the high speeds of laboratory instrumentation. The reflex became a discrete unit by which life, now understood in terms of behavior, functions, or adaptation to an environment, could be analyzed. And it was to be one of the targets, to a point of excess, of a whole sequence of vitalisms, *Lebensphilosophie*, phenomenologies, and Gestalt psychologies from Bergson through the work of Merleau-Ponty. The reflex was repeatedly critiqued as part of an attempt to reduce life and behavior to the status of a thing, to reduce the complex to the simple. As an imaginary topographical model, the reflex described a virtual circuit or pathway of neural causes and effects, and on an empirical level it was finally an untenable concept. According to Jean Laplanche, "it is a pattern derived from a false physiology, or even a puerile physiology."⁶⁵ Nonetheless, it continued to function within a much

63. Michel Foucault, *The Order of Things* (New York: Pantheon, 1971), p. 278.

64. In response to critics who asserted that psychic events were not susceptible to scientific procedures and analysis, James McKeen Cattell repeatedly asserted, with somewhat dubious logic, that since mental events and processes occur in time, and time was something measurable, it followed that mental events were quantifiable. See, for example, his "Address of the President before the American Psychological Association," *Psychological Review* 3 (1896), pp. 134–148. For Cattell, "the quantitative point of view" was essential in overcoming "a chaos of animistic and teleological conceptions."

65. Jean Laplanche, *New Foundations for Psychoanalysis*, trans. David Macey (Oxford: Blackwell, 1989), p. 6: "The idea that a stimulus applied to living tissue from the outside remains the same when it emerges from that tissue stems from an elementary and indefensible mechanism. We know that the final muscular discharge has nothing to do with *either* the stimulus energy *or* the nervous energy that is channeled through the 'reflex arc.'"

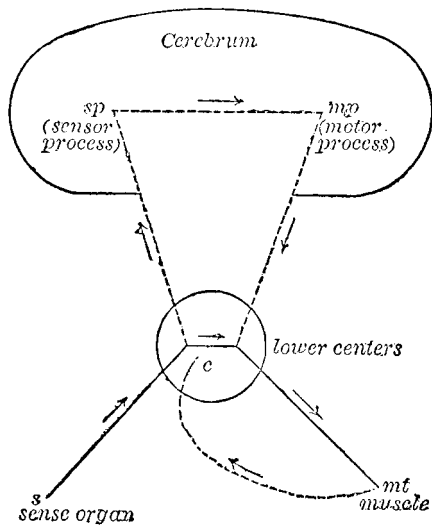

FIG. 10.

s, c, mt = reflex circuit (1. and 2. of text).

s, c, sp, mp, c, mt = voluntary circuit (3. of text).

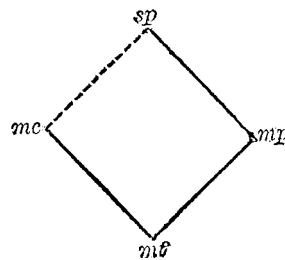

FIG. 11.

Textbook diagram of reflex arc, mid-1890s.

larger institutional project in which the human subject was figured as the object of techniques of external management and control, and it was to spawn one of the most powerful, if chimerical, notions of the Western imagination in the twentieth century: the conditioned reflex.

I raise the issue of the reflex here because historically it was one of the ways in which attention was positioned within knowledge of human behavior. Within certain schools of research, attention occupied a middle position in the reflex arc, as a component of the central cerebral process that was initiated by the onset of a stimulus and then allowed the preparation of a motor response to it. The concept of the reflex was attacked because it seemed to be either ignoring or actually decomposing an inviolable human essence, while in concrete ways producing new forms of sensory experience outside of various myths about the organic wholeness of subjectivity or the distinction between “natural” and “artificial” sensation. The enemies of the reflex persistently misrepresented its advocates, painting them as if they believed that the reflex had a unified physiological identity (which it obviously did not) or as if they believed that human life was literally only an accumulation of separate stimulus-response circuits; ignoring that for its varied proponents the reflex was really a *practical* reconfiguration of behavior that described it in

terms that facilitated or at least posed the possibility of external intervention and control.

John Dewey presented one of the most famous early critiques in his 1896 essay “The Reflex Arc Concept.” Dewey’s argument developed certain general themes that would be heard again in many places, all the way into Gestalt work of the 1920s. Essentially, he asserted that behavior cannot be meaningfully analyzed into elemental components. “The reflex arc idea, as commonly employed, is defective in that it assumes sensory stimulus and motor response as distinct physical existences, while in reality they are always inside a coordination and have their significance purely from that coordination.”⁶⁶ Dewey countered with an image of the subject in a perpetual sensory interface with the world that “is one uninterrupted, continuous redistribution of mass in motion . . . there is nothing which can be set off as stimulus, nothing which reacts, nothing which is response. There is just a change in the system of tensions.”⁶⁷ His point was that “stimulus” could never be distinguished from the *overall* state of the organism as a whole and that the individual responds not to some punctual sensation but to its own total condition, a unity of many processes and movements. At the same time, he insisted that human action always involves teleological explanation, “that organisms bring meaning into the world.”⁶⁸ Attention, then, for Dewey was not a distinct or discrete interval in the middle of a linear sequence of stimulus and response but a continuous and variable activity that was always undergoing a reorganization of its focus and intensity. He also rejected the notion that it was possible to isolate the functioning of a single sense, whether the eye or the ear, maintaining that multisensory activity was constantly in play.⁶⁹

Perhaps the most memorable part of Dewey’s critique is his characterization of the reflex as an idea that, in failing “to see the unity of activity,” dissolves both wholeness and continuity and “leaves us nothing but a series of jerks, the origin

66. John Dewey, “The Reflex Arc Concept,” *Psychological Review* 3, no. 4 (July 1896), p. 360. See the discussions of this essay in Floyd W. Matson, *The Broken Image: Man, Science and Society* (New York: Braziller, 1964), pp. 166–172; and George Herbert Mead, *Movements of Thought in the Nineteenth Century*, vol. 2 (Chicago: University of Chicago Press, 1936), pp. 389–393.

67. Dewey, “The Reflex Arc Concept,” p. 364.

68. Alan Ryan, *John Dewey and the High Tide of American Liberalism* (New York: Norton, 1995), pp. 125–126.

69. “It is absolutely impossible to think of the eye center as monopolizing consciousness and the ear apparatus as wholly quiescent. What happens is a certain relative prominence and subsidence as between the various organs which maintain the organic equilibrium.” Dewey, “The Reflex Arc Concept,” p. 362.

of each jerk to be sought outside the process of experience itself.”⁷⁰ This galvanic image, evoking various kinds of nineteenth-century experimentation in which electrical stimulation of animals produced involuntary movement, stands for an experience of shock and perceptual disjunction incompatible with Dewey’s vision of creative human activity.⁷¹ The “jerk” was in fact a vividly apt figuration of many domains of experience within an urban capitalist lifeworld in North America and Europe, whether in terms of industrial production, spectacular consumption, or technological modernization, areas of experience that involved more the automatic or passive reaction of a subject to stimuli than the discriminating awareness of individuals responding creatively with their own social environments. Dewey’s own recoil from “the jerk” is a measure of his unwillingness to recognize the extent to which his ideal of rational social and managerial control would inevitably limit and conflict with his hope for individual expression of some natural, self-adapting “coordination.”⁷² Very early on in his career, Dewey presented the image of a human subject isolated in a dark and totally unfamiliar room in which, at periodic intervals, an electric spark would be visible.⁷³ In proposing these conditions of extreme sensory impoverishment (related to tachistoscopic effects), Dewey affirmed that the individual nonetheless transcends the atomized character of this reduced perceptual field with the apperceptive experiences of anticipation, memory, and the preparation of future actions. Rather than an indifferent sequence of flashes, human life will always be a continuous process of existential adaptation and adjustment. The idea of continuity in Dewey, like the notion of the stream in James, was used to sustain an ideal of unity and wholeness without which it was assumed that an unacceptable disintegration of individual experience would oc-

70. *Ibid.*, p. 360.

71. For a quintessential example of the kind of research targeted by Dewey, see Charles S. Dolley and James McKeen Cattell, “On Reaction Times and the Velocity of the Nervous Impulse,” *Psychological Review* 1, no. 2 (1894), pp. 159–168: “An electric shock can be applied conveniently to different parts of the body. The shock may be made as strong as desired and the moment of its occurrence registered. We used electrodes of various sorts. The method we found best was to apply one electrode to the points on the skin we wished to stimulate, while the other electrode was conducted to a pail of saturated salt water in which the left foot was placed. The stimulus was given ten times in succession at the same point and then immediately switched to another point without shifting the electrodes. The shock was usually given on the left-hand side of the body, the reaction being made with the right hand or foot. . . . The shock is more piercing with a small electrode and more massive from a large electrode.”

72. “But Dewey should be regarded as halfway modernist, a brilliant philosopher who, sensing the implications of modernism, did everything possible to avoid its conclusions.” John Patrick Diggins, *The Promise of Pragmatism: Modernism and the Crisis of Knowledge and Authority* (Chicago: University of Chicago Press, 1994), p. 5.

73. John Dewey, *Psychology* (New York: Harper and Brothers, 1889), pp. 139–140. In this text Dewey does, however, acknowledge the role of shock in producing attentiveness (pp. 126–127).

cur.⁷⁴ Neither Dewey nor James ever considered the possibility that abrupt breaks or harsh disjunctions within perception might also have the capacity for revivifying or expanding the limits of thought or cognitive awareness. In fact the perceptual shock, jerk, or break, especially in its motor component, is one of the forms of modern knowledge through which the disconnected nature of reality can be directly apprehended.

The debates about the nature of perceptual experience during the 1890s turned on questions of the essential constitution of perception itself. Even amid the overwhelming philosophical and scientific acceptance of the instability, unreliability, opacities, and general limitations of the human senses, there was nonetheless a variety of efforts, including those within the visual arts, to define or determine a core functioning or manifestation of a “pure” perception. Certainly laboratory instruments like the tachistoscope were part of a quest to isolate an elemental and distilled functioning of sensory capacities, and to observe this functioning, as much as possible, outside a realm of error, distraction, and above all any introspection. Most importantly, the preoccupation with pure perception (whether in the sciences, in philosophy, or in art theory) was an interest in perceptual experience that was prior to (or distinct from) the apprehension of an image that represented an external world.⁷⁵ Had the classical camera obscura model of vision and related forms of empiricism remained culturally dominant, attention would never have become a central problem.

But what is a “pure perception” when it is no longer a question of seeing the world directly and as a unity? What happens when perception is no longer necessarily synonymous with presence? Alongside Cezanne, one of the most intense

74. Dewey was deeply interested in practical ways of enhancing mind-body unity, including forms of eurhythmy and Alexander technique. These developments are discussed in Hillel Schwartz, “Torque: The New Kinaesthetic of the Twentieth Century,” in Crary and Kwinter, eds., *Incorporations*, pp. 71–126. Dewey’s most developed reflections on the social and aesthetic importance of rhythm are in his *Art as Experience* (1932).

75. Schopenhauer’s work is an important source for many later nineteenth-century postulations of autonomous aesthetic capacities that were distinct from the processual and temporal economy of the body. In contrast to the attentiveness possible in an “ordinary” human subject, he outlines an absolute and unwavering model of pure contemplation. “Accordingly, genius is the capacity to remain in a state of pure perception, to lose oneself in perception, to remove from the service of the will the knowledge which originally existed only for this service. In other words, genius is the ability to leave entirely out of sight our own interest, our willing, and our aims, and consequently to discard entirely our own personality for a time, in order to remain *pure knowing subject*, the clear eye of the world; and this not merely for moments, but with the necessary continuity and conscious thought to enable us to repeat by deliberate art what had been apprehended, and ‘what in wavering apparition gleams fix in its place with thoughts that stand forever.’” Schopenhauer, *The World as Will and Representation*, trans. E. F. J. Payne (New York: Dover, 1966), vol. 1, pp. 185–186. (The internal citation is from Goethe’s *Faust*.)

meditations on these questions in the 1890s is in the work of Bergson. *Matter and Memory* (1896) is a text interwoven with a broad range of debates and investigations into the nature of perception and attention. In posing the question of what “pure perception” might be, it enters, like the late work of Cezanne, into a dramatic rethinking of the status of an image. Within this rethinking, what Cezanne and Bergson share is an understanding that sustained perceptual experience will never yield anything “pure” in a traditional sense, that the deepest forms of perception are irreducibly “mixed” and composite.⁷⁶ However, as I will suggest, the projects of Cezanne and Bergson are finally dissimilar, if not incompatible, in terms of their fundamental ambitions.

Matter and Memory presents a number of difficulties to a reader. It is not a systematic presentation of concepts but rather a “genetic method”—a roving exploration (and rejection) of many different hypotheses and a gradual accumulation of its own propositions about the nature of perception and memory until, through a series of advances and retreats, it arrives at its resonant concluding theses. At the heart of Bergson’s project is his attempt to establish a model of perception opposed to various routinized and reified forms of perceptual experience within Western urban and scientific culture of the late nineteenth century. In the course of the book he considers and rejects even the possibility of “pure” perception on his way to valorizing specific types of attention as types of perception with the highest ethical and aesthetic possibilities.

Pure perception, for Bergson, is an ideal that “exists in theory rather than in fact and would be possessed by a being placed where I am, living as I live, but absorbed in the present and capable, by giving up every form of memory, of obtaining a vision of matter both immediate and instantaneous.” It is the dream of an inhuman immediacy, of an externality—the idea of a primordial and fundamental act of perception “whereby we place ourselves at the very heart of things,” a perception “confined to the present and absorbed, to the exclusion of all else, in the task of molding itself upon the external object.”⁷⁷ For Bergson this dream is useful only as a hypothesis. He argues that every perception, no matter how apparently instantaneous, constitutes a duration that prolongs the past into the present, inescapably contaminating its “purity” by giving it a composite status. The sensations produced by the tachistoscope would have been an example of the impover-

76. On themes of “mixture” and “interpenetration” in Bergson, see Gilles Deleuze, *Bergsonism*, trans. Hugh Tomlinson and Barbara Habberjam (New York: Zone Books, 1988), pp. 22–27.

77. Henri Bergson, *Matter and Memory* (1896), trans. W. S. Palmer and N. M. Paul (New York: Zone Books, 1988), p. 34.

ishment of an attempt to achieve that impossible purity (and, writing in the late 1890s, he cites available research data indicating that “the smallest interval of empty time which we can detect . . . equals .002 seconds”.⁷⁸ Likewise, Bergson dismisses the notion of a pure memory or recollection and identifies the main problem that will occupy him: the various ways in which memory and perception interpenetrate each other. One of the places he begins is the assumptions behind the general concept of a stimulus-response circuit. Bergson focuses on what is ignored in such a model: the complexity of what happens *between* awareness of stimulation and reaction to it. For him this in-between is equivalent to lived experience, and it is where attention performs a pivotal role. How the attentive body and mind process sensation decides not only the nature of one’s perception but the degree of freedom of one’s own existence. There is a loose similarity with Dewey’s ideal of coordination when Bergson writes: “The role of the body was thus to reproduce in action the life of the mind, to emphasize its motor articulations as the orchestra conductor does for a musical score; the brain did not have thinking as its function but that of hindering the thought from being lost in dream; it was the organ of *attention to life*.”⁷⁹

To sketch very briefly, *Matter and Memory* demonstrates that attention always operates on two axes. One is an attentiveness to the flow of external sensations and events while the other is attention to the way in which memories coincide with or diverge from “present” perception. The degree of vital autonomy possessed by an individual is proportional to the very indetermination and imprecision with which memory intersects with perception. The more “determined,” that is, the more habitual and repetitive one’s perceptual response to one’s environment, the less autonomy and freedom characterize that individual existence. When an action follows a stimulus “without the self interfering with it,” one becomes “a conscious automaton,” and Bergson contends that the majority of our daily acts “have many points of resemblance with reflex acts.”⁸⁰ The richest and most creative forms of living occur in what he evocatively calls “a zone of indetermination.”

On its rhetorical surface *Matter and Memory* is an apparently benign text, seemingly remote from any social or cultural polemics, but nonetheless its targets

78. *Ibid.*, p. 205.

79. Henri Bergson, *The Creative Mind*, trans. Mabelle Andison (New York: Philosophical Library, 1946), p. 87.

80. Henri Bergson, *Time and Free Will: An Essay on the Immediate Data of Consciousness* (1888), trans. F. L. Pogson (New York: Harper and Row, 1960), p. 168. See the recent discussion of automatic behavior in Ellen J. Langer, *Mindfulness* (Reading, Mass.: Addison-Wesley, 1989).

are clear. As Walter Benjamin and a few others understood, Bergson's book was a major response to the general standardization of experience and automation of perceptual response at the turn of the century.⁸¹ The way in which new arrangements of spectacular consumption (especially when they were posed as novelty) within a mass society seemed to be fundamentally productive of redundancy and habit obviously disturbed Bergson.⁸² The more conditioned and predictable human behavior became, the fewer openings he saw for memory to play any inventive role in it. Benjamin called Bergson the preeminent representative of *Lebensphilosophie*, and as such it is no oversimplification to say that *Matter and Memory* is one of the great affirmations of the amplitude and complexity of human life over against the intrusion of "the mechanical," where this term designates not anything conventionally technological (as it would, say, for Spengler) but rather, as it did for his schoolmate Durkheim, an absence of complexity.⁸³ Benjamin (despite his deep reservations about Bergson's project) saw the relation between Bergson's dismay at the increasingly impoverished role of memory on an individual level and his own analysis of the decay of traditional forms of collective memory.

Bergson's elaboration of the human subject as a potential "center of indetermination" postulates a subject with the capacity to recreate the present, that is, to

81. For a historical assessment of Bergson's work and its contemporary European intellectual milieu, see Sanford Schwartz, "Bergson and the Politics of Vitalism," in Frederick Burwick and Paul Douglass, eds., *The Crisis in Modernism: Bergson and the Vitalist Controversy* (Cambridge: Cambridge University Press, 1992), pp. 277–307.

82. The theme of redundancy and habit within modernity was developed in the 1950s by Arnold Gehlen: "The phenomenon of routinization is seen everywhere, since it is connected with the progress of the division of labor; yet its bearing upon the wider question of the mechanical nature of behavior has been seen only by Bergson. Even Freud, in his thoughts and masterly investigations of the psychological processes evidenced in the wants and dreams of the neurotic inhabitants of great cities, failed to pay attention to this theme. In our social capacities we often act 'schematically,' that is, we enact habitualized, well-worn behavior patterns which unfold 'by themselves.' This can be said not only of behavior of a practical, external nature, but also—and primarily—of the internal components of behavior. The formation of thoughts and judgments, the emergence of evaluative emotions and decisions—all these things are largely automatized." Gehlen, *Man in the Age of Technology* (1957), trans. Patricia Lipscomb (New York: Columbia University Press, 1980), p. 143. The necessary relation between "processes of habitualization" and the functioning of social institutions is crucial in Peter L. Berger and Thomas Luckmann, *The Social Construction of Reality: A Treatise in the Sociology of Knowledge* (New York: Anchor, 1967). The authors indicate that the operation of stable social routine depends on "a low level of attention" (p. 57).

83. Bergson repeatedly refers to a "reaction machinale" in *Matter and Memory*. Georges Canguilhem asserts that "Bergson is one of the rare French philosophers, if not the only one, who has considered mechanical invention as a biological function, an aspect of the organization of matter by life," in "Machine and Organism" (1952), in Cray and Kwinter, eds., *Incorporations*, p. 69. Bergson and Durkheim entered the Ecole Normale Supérieure in 1878–1879. On their shared intellectual formation, see Steven Lukes, *Emile Durkheim: His Life and Work* (Stanford: Stanford University Press, 1973), pp. 44–50.

escape from a relationship of constraint and necessity with one's lived milieu. The book is saturated with some basic evolutionary assumptions: the highest and most developed organisms (human beings) potentially have the most independence from compulsory reaction to environmental stimuli. "In a word, the more immediate the reaction is compelled to be, the more must perception resemble a mere contact. . . . The degree of independence of which a living being is master, or shall we say, the zone of indetermination which surrounds its activity, allows, then, of an a priori estimate of the number and distance of the things with which it is in relation. . . . From this indetermination, accepted as a fact, we have been able to infer the necessity of a perception, that is to say a *variable* relation between the more or less distant objects which interest it."⁸⁴ In one sense Bergson is endowing his own model of a "disinterested," aesthetic relation to the world with an evolutionary and biological underpinning. The fact that our nervous systems not only can delay response to a stimulus but have the possibility of "variable" responses is a precondition of a free and autonomous subject. But what made this variability important were the ways in which perception was penetrated by "a thousand details out of our past experience," and Bergson provides an extended commentary on what goes into determining the particular quality of this "mingling" of memory and perception. He indicates that the interaction can happen in ways that are either creative or reactive and habitual, but makes it clear that the latter is what occurs most often.

An unacknowledged target in *Matter and Memory* is the epistemological work of Helmholtz, which for several decades contained one of the most influential explanations of the role memory plays in perception. This was his controversial theory of "unconscious inference" (*unbewusster Schluss*). Helmholtz's account of perception (which includes not only his own discoveries but also a synthesis of the most important contemporary work on optics, physiology, and sensory experience) was a compelling announcement in the nineteenth century of the nonveridical status of vision and perception. As much as any single figure, Helmholtz established the powerful position that there is no necessary or direct correspondence between sense experience and objects in the world. Not only did his exhaustive inventory of the physiology of vision and hearing reveal the undependability of the senses, but it set the ground for the gradual rationalization

84. Bergson, *Matter and Memory*, pp. 32–33; emphasis in original. On the importance of this concept, see the analysis in Bruno Paradis, "Indetermination et mouvements de bifurcation chez Bergson," *Philosophie* 32 (1991), pp. 11–40.

and instrumentalization of the senses through the transfer of their functions to machinic and technical prostheses of various kinds. But if, as I have discussed elsewhere, Helmholtz stands for the thorough uprooting and dislocation of vision from the stationary relations of a classical model of geometrical optics, his work also undertakes a reciprocal “reterritorializing” and disciplining of perception. The “uprooting” and destabilization is evident in assertions such as the following:

In my opinion, there can be no possible sense in speaking of any other truth of our own ideas except as a *practical* truth. Our ideas cannot be anything but symbols, natural signs for things we learn how to use in order to regulate our movements and actions. Having learned correctly how to read those symbols, we are enabled by their help to adjust our actions so as to bring about the desired result; that is, so that the expected new sensations will arise.⁸⁵

Clearly this part of his work had potentially nihilistic implications. His assertion that sensation had no necessary link to a referent obviously endangered any coherent system of meaning. To counteract these suggestions, Helmholtz patched together a set of epistemological positions that at least had the effect of mitigating the disruptive possibilities of his empirical work.⁸⁶

Helmholtz, unlike Bergson, Nietzsche, or Cezanne, was committed to expanding and optimizing the productive functioning of a socioeconomic world (in particular that of imperial Germany). As Anson Rabinbach and others have shown, his groundbreaking work on thermodynamic principles was inseparable from a vision of capitalist industrialization in which human beings were essentially energy-transforming machines.⁸⁷ His formulations about the conservation of force not only provided new models of the relation between energy and labor but also stood as scientific confirmation of the operations of exchangeability and convertibility inherent in capitalist modernization. The research of Helmholtz, and also of Julius Mayer and Justus von Liebig, generated the conclusion that “all of nature

85. Helmholtz, *Treatise on Physiological Optics*, chap. 26, p. 19. For a concise account of Helmholtz's theory of signs, see Ernst Cassirer, *Substance and Function*, trans. William C. Swabey (New York: Dover, 1953), pp. 304–306.

86. On some of the philosophical contradictions in Helmholtz's thought, see R. Steven Turner, “Helmholtz, Sensory Physiology and the Disciplinary Development of German Psychology,” in William R. Woodward and Timothy G. Ash, eds., *The Problematic Science: Psychology in Nineteenth Century Thought* (New York: Praeger, 1982), pp. 147–166.

87. See Anson Rabinbach, *The Human Motor: Energy, Fatigue, and the Origins of Modernity* (New York: Basic Books, 1990), pp. 52–83, especially his discussion of “the marriage of Marx and Helmholtz.”

was governed by some fundamental ‘equivalence.’”⁸⁸ But at the same time the cognitive relation of individuals to this world of moving forces and to the transformability of matter had to be predictable enough to insure an orderly and efficient social environment. Thus Helmholtz’s epistemology was not derived from the unstable events of thermodynamics but from a representational and quasi-logical order of signs. From this we get one of the jarring divides in his work: his ontology is a physics, but his epistemology is a semiotics. His theory of unconscious inferences is finally an attempt to provide a regulated, differential system of meaning in spite of our remove from direct experience of the world, in spite of the fact that signs have been rendered arbitrary by universal equivalence. In the face of this, Helmholtz insists, we nonetheless can have stable and reliable knowledge which at least simulates a lost order of reference, and we can in a practical sense believe in the permanence of objects, which his physics and physiology of vision put in question. Like Bergson and others, Helmholtz believed that perception was always supplemented by recollections, but his was a very different account of the potential of memory. For Helmholtz, motor and sensory memories were drawn on in every perception to compare and confirm the consistency of a subjective relation to external events and objects. Memory was little more than a reservoir or accrual of habits that assisted the mind in making cognitive judgments: determining degrees of identity or difference with past experiences. The verdict of habitual repetition was part of what maintained an orderly social world and affirmed the validity and durability of existing relations.⁸⁹

88. Ilya Prigogine and Isabelle Stengers, *Order out of Chaos: Man’s New Dialogue with Nature* (New York: Bantam, 1984), p. 109.

89. “The Facts in Perception,” delivered in 1878, was one of the lectures in which Helmholtz summarized most comprehensively his theory of perception and knowledge. In it the overlap between Helmholtz’s anxiety about the social disruptions of that historical moment and his presentation of a quest for the laws of thought are inescapable. He declares that his audience inhabits a “period when cynical contempt for every ideal possession of humanity is propagated on the streets and in the press and has reached its peak in two revolting crimes,” referring to recent assassination attempts on Kaiser Wilhelm I, in whom is “united everything that humanity, up to now, has regarded worthy of veneration and gratitude.” Political freedom, he says, has led to “such dubious processes.” Following this sycophantic prologue, he enters into the importance of the need for an orderly account of how we know the world. Helmholtz, *Science and Culture: Popular and Philosophical Essays*, trans. David Cahan (Chicago: University of Chicago Press, 1995), p. 343. Later Helmholtz was also disturbed by the widespread appropriation of his theory of “unconscious inferences” by representatives of philosophical “irrationalism,” in particular in the work of Eduard von Hartmann. A subsequent generation of psychologists also rejected the concept of the unconscious as useful to scientific research and sought to reread Helmholtz’s theory as one of “association,” criticizing his terminological choices. See, for example, the evaluation by Carl Stumpf, “Hermann von Helmholtz and the New Psychology,” *Psychological Review* 2, no. 1 (January 1895), pp. 1–12. On the cultural and political context of Helmholtz’s work, see Timothy Lenoir,

For Bergson, Helmholtz's "unconscious inferences" made perception into something mechanical and automatic and rendered it compatible with a functional immersion in the present. Rather than relations of confirmation or adjustment between memory and perception, Bergson was interested in "a rift [une fissure]" that can occur between the two, when a memory transforms present perception in ways that detach it from the service of adapting to the present. He maintains that "the practical and useful consciousness of the present" is a block to the richer functioning of memory.⁹⁰ But the block can be overcome, and what is necessary for accomplishing this is a capacity for attention. Not the impoverished model of attention that was promulgated by Ribot, Wundt, or many others: that is, attention as a state of motor inhibition in which selected mental contents acquired clarity and centrality. For Bergson, these aspects of attention were not to be dismissed, but they were only the opening stage, a "preparation," for its true functioning.

Attention may in fact begin with what Ribot and others described as a condition of relative motor arrest and so forth, but then there is a decisive shift: attention "gives up the useful effect of a present perception" and begins a "backward" movement of the mind. Obviously Bergson's use of "backward" is provisional here, since he rejected any spatialization of time and believed that the past coexists with its own present. Bergson detailed an attentiveness that could grasp this coexistence or multiplicity. Attention would thus allow memory "to create anew" a present perception, strengthening and enriching it. Also this operation of attention "may go on indefinitely . . . which in its turn becoming wider, draws into itself a growing number of complementary recollections."⁹¹ "By allowing us to grasp in a single intuition multiple moments of duration, [memory] frees us from the movement of the flow of things, that is to say, from the rhythm of necessity."⁹² Bergson sought to describe the revelatory vitality, even the shock, of a moment when memory ceases to merely confirm or adjust a perception and instead opens up a reverberating process of "endosmosis," of remaking an object of perception, of creating

Instituting Science: The Cultural Production of Scientific Disciplines (Stanford: Stanford University Press, 1997), pp. 131–178.

90. Bergson, *Matter and Memory*, p. 95.

91. *Ibid.*, p. 101. Ruskin's work is one of many places in the early and mid-nineteenth century where some related formulations are intuited or suggested. See, for example, Ruskin's dismissal of a "direct intuition" that sees forms and relations as fixed in favor of a perception of a "vital truth" through which "past history, present action," and "the way things are going" are all visible in a given form simultaneously, in *The Elements of Drawing* (1857; New York: Dover, 1971), p. 91.

92. Bergson, *Matter and Memory*, p. 228.

something new. “Attention to life” is the preeminent human capability for Bergson in *Matter and Memory*: it is what allows an intuition of singularity rather than of the bleak redundancies of representations. According to Deleuze, “attention gives back to duration its true characteristics. . . . It is not simply succession but a very special coexistence, a simultaneity of fluxes,” in which the body was always implicated.⁹³ The awareness of that coexistence is what situates an individual in a “zone of indetermination,” a zone of freedom radically different from the quasi-logical order of Helmholtz’s unconscious inferences.⁹⁴

However, attention for Bergson was also allied with certain normative assumptions about mental and perceptual activity, which developed partly through his awareness of the parallel work of Pierre Janet.⁹⁵ “The degree of our attention to life” becomes the fluctuating indicator of psychic health for both thinkers. For Bergson, “that which is commonly held to be a disturbance of the psychic life itself, an inward disorder, a disease of the personality, appears to us, from our point of view, to be an unloosing or a breaking of the tie which binds this psychic life to its motor accompaniment, a weakening or impairment of attention to outward life.”⁹⁶ Like Janet, Bergson posed attention as a binding together of reality to ward off both perceptual and psychic disintegration, and he borrowed from Janet a notion of a “tension” whose slackening indicated a pathological debilitation of the will. “Relax this tension or destroy this equilibrium: everything happens as if attention detached itself from life. Dreams and insanity appear to be little else than this.”⁹⁷ Bergson’s use of Janet’s “reality function” makes clear that his intuition

93. Deleuze, *Bergsonism*, p. 81.

94. “According to Bergson there is an element of irreducible contingency or indetermination in each moment of our psychological history. Each moment of our psychological duration constitutes a genuine—and not merely spurious—novelty, indivisible and consequently unanalyzable into its components for the simple reason that there are no ‘components’ present. . . . This means that even in his first book [*Time and Free Will*, 1888] Bergson’s target was far wider than associationism and psychological determinism; it was *determinism in general*, whether of a physicalist or an idealist type. His original aim was to uphold relative human freedom or, more specifically, an element of irreducible novelty in each moment of psychological duration.” Milic Capek, *Bergson and Modern Physics: A Reinterpretation and Reevaluation*, Boston Studies in the Philosophy of Science, 7 (Dordrecht: Reidel, 1971), p. 100. Bergson’s early attack on the psychometrics of Weber, Fechner, and Delboeuf in *Time and Free Will* is discussed in W. W. Meissner, “The Problem of Psychophysics: Bergson’s Critique,” *Journal of General Psychology* 66 (1962), pp. 301–309.

95. Bergson revised *Matter and Memory* numerous times in the decade following its appearance in 1896, updating it with new citations. Janet’s *Obsessions et psychasthenie* (1903) was the initial formulation of his theory of “psychological tension,” which impressed Bergson in relation to his own notion of attention.

96. Bergson, *Matter and Memory*, pp. 14–15.

97. *Ibid.*, p. 174.

of an ever-expanding interpenetration of past and present is possible only from a secure psychic and sensorimotor grounding in the reality of one's own present. "Is it not likely, therefore, that the loss of mental equilibrium in the insane is simply the result of a disturbance of the sensori-motor relations established in the organism? This disturbance may be enough to create a sort of psychic vertigo and so cause memory and attention to lose contact with reality."⁹⁸ By the early twentieth century there was a pervasive though vague clinical designation of a condition called "the feeling of unreality," which was linked to a failure of an apperceptive attention: a feeling of unreality resulted when present impressions did not link up with memory associations, resulting in a sense of the unfamiliarity of present objects.⁹⁹

Thus we have the paradox of Bergson sketching out the marvels of a multidimensional perception capable of apprehending and creatively engaging the immanence of the past in the present, and at the same time defending a quasi-normative perception that had to be sharply distinguished from dreams and insanity. Attention, for Bergson, also becomes a bulwark against the weakening, constriction of activity, and disintegration of the will implied by these states. It is not often noted how inconsistent Bergson's anxious treatment of madness and dreams is in relation to the pervasive ideas of his work. He argues ceaselessly against the proposition of discrete or separate states of mind, events, experiences, even objects. But his privileging of fusion, interpenetration, and continuity does not apply to insanity, dreaming, or other borderline states: he has no hesitation in severing them from a normative model of consciousness.¹⁰⁰ Thus his model of attention is one that does

98. Ibid. Paul Valery was also wary of the outer limits of his model of a concentrated or fixed attentiveness: "Yet there is nothing more powerful in the imaginative life. The chosen object becomes as it were the center of that life, a center of ever multiplying associations, depending on whether the object is more or less complicated. Essentially this faculty must be a means of exciting the imaginative vitality, of setting potential energy to work. Carried too far it becomes a pathological symptom and gains a frightening ascendancy over the increasing feebleness of a decaying mind." Valery, *Collected Works*, vol. 8, p. 27.

99. See, for example, August Hoch, "A Review of Some Recent Papers upon the Loss of the Feeling of Reality and Kindred Symptoms," *Psychological Bulletin* 2, no. 7 (July 15, 1905), pp. 233–241; and Frederic H. Packard, "The Feeling of Unreality," *Journal of Abnormal Psychology* 1 (1906), pp. 69–82. In the latter, the condition is linked to an attention in which there is damage to an apperceptive capacity. "If the present impression does not call up the necessary associations from the memory residua there can be no apperception" (p. 77). One significant optical consequence of this failure is that "solid objects look flat" (p. 80).

100. See the discussion of Bergson and dreams in Madeleine Barthelemy-Madaule, *Bergson* (Paris: Seuil, 1967), pp. 86–90; and in Gilles Deleuze, *Cinema 2: The Time-Image*, trans. Hugh Tomlinson and Robert Galeta (Minneapolis: University of Minnesota Press, 1989), p. 56.

not waver, oscillate, or drift in and out of focus. When attention is relaxed or weakened, it is a sign of a deficiency of the will, and perception itself changes into something qualitatively different and less valuable at that point. No longer, he believed, does it grasp the interpretation of past and present, falling into a lower, desultory mode of operation in which events, impressions, and recollections are merely spatial and juxtaposed, a mode in which attention simply moves “from one thing to another” without an intuition of their higher unity within pure duration.

Bergson wanted an impossible attentive concentration, an absorption that would never lose its conscious connection to the willed activity of the body. He posited the subject as a “center of indetermination” but could not accept that this “indetermination” might encompass fluctuations in and out of trancelike states in which dissociated phenomena could occur. His work consistently fought the idea of fixed pathways or inflexible memory loops in psychic life (such as Helmholtz’s habitual unconscious inferences or reflex circuits) because of the way they “spatialized” and localized memory. Yet he dismissed as unimportant the actual subjective experiences and processes that incarnated the most piercing forms of nonspatialized experiences, such as dreamwork, trance, or forms of hypnagogic vision.¹⁰¹ In particular, Bergson ignored experiences like the singular state between wakefulness and sleep in which sensory input and motor activity is reduced, leading to the sudden releasing of vivid sensory memories and images. A case could well be made that hypnagogic perceptions are the most common subjective conditions under which most individuals have known a powerful penetration of the present by memory. Such events could occur in both hypnagogic reverie and under hypnotic suggestion.¹⁰² But a great fear in Bergson’s work of this period is of perceptual behavior that is either passive or automatic, and clearly *Matter and Memory* coincides historically with the construction of various forms of automatic perception in cinema, recorded sound, and other technological arrangements, in

101. Jean-Paul Sartre noted the atopic, nonspatialized character of hypnagogic perception in his *The Psychology of the Imagination* (1940), trans. Bernard Frechtman (New York: Philosophical Library, 1948), pp. 49–50.

102. Twentieth-century research proposed that in hypnagogic states “emotional and sensory images out of the past are revived with undiluted intensity because of the lessened opportunity to make comparisons with actual concurrent sensations. Furthermore, . . . in hypnagogic reveries olfactory, gustatory, tactile and kinaesthetic memories can likewise escape all customary repressive influences and therefore are experienced with exceptional vividness. This seems to open a pathway to many otherwise inaccessible memories.” Lawrence S. Kubie and Sydney Margolin, “The Process of Hypnotism and the Nature of the Hypnotic State,” *American Journal of Psychiatry* 100 (March 1944), p. 613. See also Andreas Mavromatis, *Hypnagogia: The Unique State of Consciousness between Wakefulness and Sleep* (London: Routledge, 1987), esp. pp. 67–71 on diffuse and absorbed attentiveness in hypnagogia.

which premade images were consumed passively.¹⁰³ Photography (though he does not explicitly mention it in *Matter and Memory*) seems to be his implicit model for the depreciation of experience when individual memory images “are stiffened into ready-made things [en choses toutes faites].”

For Bergson, Janet, and many others, automatic behavior was seen as posing a dangerous dissolution of ego boundaries in which the individual will ceased to exert itself. Bergson’s “attention à la vie” was a spreading or dilation of the personality over a wider and wider surface. Automatic behavior implied a reverse narrowing or contraction of the personality, a scattering of the self.¹⁰⁴ (Later in his career, Bergson was to declare that his concern with attention and psychological tension was inseparable from the problem of schizophrenia).¹⁰⁵ This notion of “personality” also resonates with Janet’s delineation of “psychasthenia” in the late 1890s as the impairment of an individual’s capacity to engage fully in reality. The marks of a normative engagement were attentiveness and awareness of the present; the contrary indications were a failure of attention, a disengagement from the present, a feeling of “depersonalization,” and feelings of emptiness (“le sentiment du vide”).¹⁰⁶ But Bergson could not admit to the fundamental ambivalence of attention, to the experience of rapt concentration imperceptibly melting into a blank intuition of vacancy, of the “void” that Janet sought to pathologize.

Departures from a normative consciousness, in particular experiences of dissociation in trance, dreams, and other states, Bergson dismissed as having no revelatory, affirmative, or creative value. *Matter and Memory* is his attempt to reconceive dissociation in a form that would preserve a unified ego and a consciousness grounded in a world of action. Bergson recognized the problematic

103. See the account of Bergson’s importance for modern rethinkings of visuality in Martin Jay, *Downcast Eyes: The Denigration of Vision in Twentieth-Century French Thought* (Berkeley: University of California Press, 1993), pp. 186–209.

104. “But suppose we let ourselves go and, instead of acting, dream. At once the self is scattered; our past, which was till then gathered together into the indivisible impulsion it communicated to us, is broken up into a thousand recollections made external to one another. They give up interpenetrating in the degree that they become fixed. Our personality descends in the direction of space.” Henri Bergson, *Creative Evolution* (1907), trans. Arthur Mitchell (New York: Random House, 1944), pp. 220–221.

105. Bergson, *The Creative Mind*, p. 88. The psychiatrist Eugene Minkowski would later use Bergson’s work for a schematic explanation of schizophrenia as a “discordance” and lack of integration between an intuition of existence as a pure inert spatial present and as a continuity of lived time. See Eugene Minkowski, “Bergson’s Conceptions as Applied to Psychopathology,” *Journal of Nervous and Mental Disease* 63, no. 4 (June 1926), pp. 553–568.

106. See Pierre Janet, *Les obsessions et la psychasthénie* (Paris: Alcan, 1903), pp. 475–501. On this dimension of Janet’s work, see Björn Sjøvall, *Psychology of Tension: An Analysis of Pierre Janet’s Concept of “Tension Psychologique”* (Stockholm: Svenska Bokforlaget, 1967), pp. 73–96.

relation of attention to presentness and immediacy, but was unable to allow anything into his theory that would acknowledge its continuity with experiences of drift, reverie, trance, or dream. His model of a composite yet utterly indissoluble perception in which past and present coexist is an imaginary imposition of unity on contents that are irreducibly dissociated. In a sense it is an impossible counter-model of dissociation: a synthesis of all the fragments of lived time into an experience of wholeness so rich and intense as to be an antidote to forms of alienation or reification in a contemporary social world. Bergson's work then is a striking refashioning of the Rousseauian conviction of the truth and authenticity of (inner) subjective experience, without grasping how that experience is determined by forces external to the subject.¹⁰⁷ It is here that we can best understand Benjamin's ambivalence about Bergson: he saw the latter attempting to overcome the degradation and devaluation of experience within a modernizing culture founded on amnesia and obsolescence, but he deplored Bergson's assurances that the damaged character of memory and perception could be healed on a purely subjective level, through individual acts of will. "On the contrary," wrote Benjamin, "he [Bergson] resists any historical determination of memory. He thus manages to stay clear of that experience from which his own philosophy evolved or, rather, in reaction to which it arose. It was the inhospitable, blinding age of big scale industrialism."¹⁰⁸ In the face of this economic system based on the continual production of novelty and on continual perceptual change, Bergson, like Ruskin, Pater, and many others, tried to salvage a subjective mode of apprehending novelty that was external to the imperatives of modernization, that would be a hard-won compensation for

107. Georg Lukacs saw in modernist thinkers like Bergson a fundamental denial and evasion of capitalism's "distortion" of the experience of time: "Time appears as no longer the natural, objective and historical medium in which men move and develop. It is distorted into a dead and deadening outward power. The passage of time is the frame within which a person suffers degradation. It turns into an independent and remorseless machine which flattens, levels and destroys all personal plans and wishes, all singularity, personality itself." Lukacs, *Essays on Thomas Mann*, trans. Stanley Mitchell (New York: Grosset and Dunlap, 1965), p. 79.

108. Walter Benjamin, *Illuminations*, ed. Hannah Arendt, trans. Harry Zohn (New York: Schocken, 1969), p. 157. Fredric Jameson makes a related assessment of Bergson's ahistorical understanding of time: "Yet it is not enough merely to make a place for temporality; even Bergson, who first in modern times revealed the essential spatiality of logical concepts and insisted on the uniqueness and specificity of lived time and *durée* as opposed to them, failed to evolve an adequate formulation of the reality of time. For insofar as he defined the latter as process or change, it is always in another sense the same at any moment; Bergson never managed to think his way through to the fundamental conceptual category which presides over the experience of the future and which is precisely the *novum*, the utterly and unexpectedly new, the new which astonishes by its absolute and intrinsic unpredictability." Jameson, *Marxism and Form: Twentieth-Century Dialectical Theories of Literature* (Princeton: Princeton University Press, 1971), p. 126.

the collapse of “auratic” perception.¹⁰⁹ Pater’s aestheticism could even be seen as enjoining an unattainable permanent attentiveness to every facet of one’s lived experience. There were others for whom the value of novel and defamiliarized perceptual experiences was more problematic. In the work of Hugo von Hofmannsthal, for example, the idea of detaching visual attentiveness from “the simplifying eye of habit” posed a disturbing “vertigo” of perceptual disintegration.¹¹⁰ But none of these figures can be seen in isolation, and Bergson’s proposal of a human subject as a living system in a constant condition of self-transformation and self-renewal was in fact parallel to a larger dynamic of perpetual transformation within capitalist modernization. Bergson could not see the ways in which capitalism itself was a nonfixable *duree*, a nonrepresentable variation which produced an endless chain of dislocations and destabilizations, and thus its own virtual realm of novelty.



Returning to Cezanne’s work of the late 1890s, we can identify a very different set of discoveries about the dynamics of perception than in *Matter and Memory*. From a now exhausted modernist standpoint, Cezanne might have seemed to approximate Bergson’s model of pure perception—that absolute absorption in the present which molded itself to the external object. But the rigor and intensity of Cezanne’s quest for presence disclosed to him its impossibility and opened up for him a view of the mixed and “broken” character of a fully absorbed perception.

109. Ruskin and Pater both position perception within an ethical imperative to continually apprehend the novel and the singular, to intuit the temporal unfolding of creative forces and processes within matter. It is a question of the infinite renewability and inexhaustibility of vision in the face of its susceptibility to habit and routine. Pater’s famous admonition is relevant here: “It is only the roughness of the eye that makes any two persons, things, situations, seem alike.” *The Renaissance: Studies in Art and Poetry* (1873; Berkeley: University of California Press, 1980), p. 189. Ruskin, for example, celebrates medieval art as an aesthetic universe “capable of perpetual novelty,” deploying forms that “admitted of millions of variations,” in *The Stones of Venice* (1851; New York: Hill and Wang, 1964), pp. 167–168. Elsewhere Ruskin writes: “It is that life of custom and accident in which many of us pass much of our time in the world; that life in which we do what we have not purposed, and speak what we do not mean, and assent to what we do not understand; that life which is overlaid by the weight of things external to it, and is moulded by them, instead of assimilating them; that, which instead of growing and blossoming under any wholesome dew, is crystallized over with it, as with hoar frost, and becomes to the true life what an arborescence is to a tree, a candied agglomeration of thoughts and habits foreign to it, brittle, obstinate, and icy, which can neither bend nor grow.” Ruskin, *The Seven Lamps of Architecture* (1848; New York: Noonday, 1977), p. 143.

110. Hugo von Hoffmannsthal, “The Letter of Lord Chandos,” in *Selected Prose*, trans. Mary Hottinger et al. (New York: Pantheon, 1952), pp. 134–135. Modernist decomposition of a perceptual field (such as he describes in his essay on Van Gogh, “Colours,” in *ibid.*, pp. 142–154) was of value for Hoffmannsthal only if it preserved and renewed contact with an objective world, with “the safe ground under his feet.” See the discussion of Hoffmannsthal and other fin-de-siecle writers, in Andreas Huyssen, “The Disturbance of Vision in Vienna Modernism,” *Modernism/Modernity* 5, no. 3 (September 1998), pp. 33–47.



Paul Cézanne, Pines and Rocks, c. 1900.

At stake is how the discontinuities and disjunctions he discovered became the basis for new models of synthesis and perceptual organization. What kind of synthetic operations did he undertake and what goals were they in the service of? To what extent do his late works pose their own possibilities of “an attention to life”? These are questions that can only be answered provisionally and only through an immersion in the work itself.

Pines and Rocks, from the late 1890s, is a particularly rich example.¹¹¹ It has elicited familiar responses to its apparent structural clarity, to the way in which the emphatic verticals of the pine trees seem to impose an architectonic stability, as if organizing the work into a taut planar screen. That is, it has been positioned as a “late” Cezanne, but still a prelude to the fuller disintegration of the object and dramatic transformation of chromatic practice in the works of 1902–1906. This distinction is not useless; for there is a sense in *Pines and Rocks* that Cezanne may still have some residual allegiance to older models of synthesis and structure that would be more thoroughly jettisoned within a few years, even as certain areas of the painting (the foliage and sky) are clearly consistent with work from after 1901 or so. But rather than label it as a transitional work, it is more important to understand its internal disjunctions as a singular attempt by Cezanne to engage the vacillations and the heterogeneous character of his own perceptual experiences.

Richard Shiff rightly indicates how *Pines and Rocks* “preserves the sense of an even distribution, or a tension, of warm and cool colors in nearly every area of the painting,” which undermine both spatial hierarchy and conventional pictorial orientation.¹¹² I believe it is also valuable to isolate several distinct optical systems that are only loosely held together by the composition of the work. One essential feature is what I will refer to as the diagonal “swath” that runs from the midleft hand side of the work to the lower right corner, representing a jumble of rocks and boulders, saturated with violet and flesh colors. It stands out as a “clearing” in the midst of the play of light and foliage both above and below and constitutes a band of volume and solidity in which the rocks seem to take on a weighty three-dimensional identity. It is a narrow zone in which some relatively conventional notations of modeling and foreshortening seem to carve out illusionistic relief, in opposition to the more two-dimensional systems of the vibrant texture of colored

111. The painting has often been dated 1900. John Rewald situates it slightly earlier in Rubin, ed., *Cezanne: The Late Work*, p. 392.

112. Richard Shiff, *Cezanne and the End of Impressionism* (Chicago: University of Chicago Press, 1984), pp. 122–123.

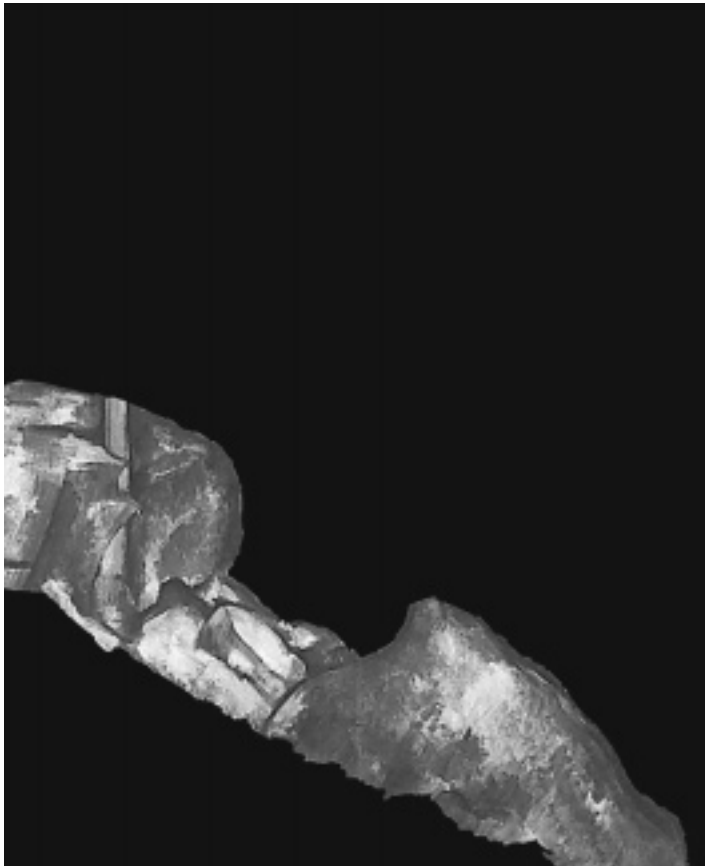

Cézanne, *Pines and Rocks*, author's diagram.

patches at the bottom and the curtain of pines and sky above or “behind” it. In a general sense I will label this swath as a “scenic” space, with at least a few isolated suggestions or fragments of orthogonals (such as in the “cubic” rock at the left) but which are not in any way integrated with the rest of the painted surface. It has something of the abrupt and detached appearance of relief amid planar elements associated with stereoscopic imagery.¹¹³ One might go further and characterize it as

113. On the stereoscope's disjunct mix of planar and relief effects, see my *Techniques of the Observer: On Vision and Modernity in the Nineteenth Century* (Cambridge: MIT Press, 1990), pp. 124–126; and Rosalind E. Krauss, “Photography's Discursive Spaces,” in *The Originality of the Avant-Garde and Other Modernist Myths* (Cambridge: MIT Press, 1985), pp. 137–138.

a local region of relative focus and clarity (in terms of the “topological” model of the visual field discussed above), in contrast to the indefiniteness of a periphery. But this area of focus, where objects take on identity, is not concentric but rather a transverse strip across the visual field, whose contents have a legibility of a distinctly different quality than the more nebulous areas of the rest of the painting. It is as though a concentrated attentiveness is at work simultaneously with a more diffuse attention, both operating with equal intensity.

The group of rocks is divided into three main sections: at the left a cubelike rock with a tree growing through it, at the right a large conical, perhaps breast-shaped rock, and in the middle a sort of negative space as if a piece of stone had once been cut away from the other two, leaving some low rock formations in between. Within the range of Cezanne’s late work it would be difficult to point to another category of motif (other than Mont Sainte-Victoire) that appears so immediately solid, fixed, and enduring. Yet Cezanne’s attraction to rock motifs in work of this period is almost always to various splinterings and dispersals of rocks, often intermingling them with ruins of man-made stone structures and with surrounding veils of trees and foliage.¹¹⁴ The diagonal swath here, descending steeply from left to right, heightens a sense of the forces of gravity, of geological erosion, of an inexorable disintegration of substance even as the rocks simultaneously incarnate a resistance to such drift and entropy. And it is within this swath that we see Cezanne struggling with, finally reconceiving, the problem of synthesis.

The most significant detail in the painting is the tree at the left—in particular, the way in which the tree is in the grip of the cubelike rock. This image becomes a powerful figuration of Cezanne’s own understanding of the dynamic reciprocity of perceptual fixation and disintegration. Initially it might seem useful to link Cezanne with my discussion of Manet’s *In the Conservatory*, to see this motif as a related attempt to bind the contents of the work into a structure that would resist its own centrifugal forces. But if Cezanne’s procedures here can be understood as “binding,” it is in terms of a transformed representational logic. The pine tree enfolded in the slit of the rock may be an attempt at anchorage, but it is an operation of fixing, of fastening, within a world in which *position* no longer has its former meanings. That is, Cezanne articulates the interpenetration of the tentatively “scenic” space of the rock swath with the flickering screen of sky and trees, embedding

114. Several other paintings by Cezanne from the same period have close affinities with *Rocks and Pines*, for example *Dans le parc du Chateau Noir*, c. 1898 (V. 779; R. 878); *La citerne dans le parc du Chateau Noir*, c. 1900 (V. 780; R. 907); and *Sous-bois devant les grottes audessus du Chateau Noir* (V. 787; R. 880).



Cézanne, Pines and Rocks, detail of rock and tree at center left.

two irreconcilable treatments of space one within the other. In a more important way this image of an eroticized enclosure becomes a diagram of Cézanne's own intuition of a perception that simultaneously seeks to grasp and be grasped, to envelop and be enveloped by the world, a perception that has abandoned a distanced point of view for a physical enfolding within a visual field. We see a related motif of enclosure in the shallow rock formation in the middle where one stone lies nested or wedged within the embrace of another, as if limbs intertwined.

But at this point in Cézanne's life, in the late 1890s, he is discovering the countless ways in which any attempt to seize or to hold onto presences, to stabilize perception, will open onto disintegrations and transformations. His encounter with the most inert and rooted form of matter turns into an intuition of metamorphoses, of inflections, of the radical fluidity of the world. For example, the longer one studies the rock at the left the more its apparent weightiness and cubic solidity breaks down into three separate and disjunct shapes adjacent to the tree trunk. The section of rock that appears to cover part of the tree has a highly ambiguous spatial identity, having only partial indications of three-dimensionality. The promi-

ment rock at the lower right has an even more precarious status as object. The other rocks have at least the suggestion of what could be called orthogonals; here volume is suggested not by any coherent system of modeling but by the voluptuousness of contour. But the contour here is emphatically discontinuous: the left side, astonishingly, is an abstract, autonomous S curve, a mathematical line of continuous variation, hovering at the heart of the painting. The contour of the right side is a very different kind of line, feathered and imprecise, made up of tentative retracings, leading toward the lower right corner where it folds back upon itself, hinting at an embryonic division within the rock itself. At the same time the lower region of this rock loses any solidity as it merges with the vibrating touches of color which flood across the bottom of the painting.¹¹⁵

The disjunct composition of *Pines and Rocks* that I've indicated here is in part due to the simultaneous operation of two disparate forms of attentiveness. Jean-François Lyotard has argued that the work of Cezanne and Freud were related abandonments of a principle of psychic unification, and that both discovered the productivity and creativity of *dispersed* perceptual and psychic processes.¹¹⁶ One of Freud's achievements by the mid-1890s was to have postulated a system of mental life in which perception and attention were two fundamentally different forces. In his quixotic "Project for a Scientific Psychology," Freud outlined how perception, as an interface of the nervous system with the world, was more powerfully determined by another interface: that between consciousness and the "stored" stimuli of wishes, memories, anticipations.¹¹⁷ What Freud struggled with in the "Project" was the problem of how specifically to account for *communication between* these systems.¹¹⁸ Physical perceptions of an external world (as a class of excitation) are merely one unprivileged component of a system in which energy is continually being circulated, transformed, and discharged. For Freud in this text,

115. Writing about *Pines and Rocks*, Richard Shiff observes: "In the area of 'foliage' in the foreground of this landscape, patches of yellow-green, red-orange, and blue-violet create a coloristic field of brilliance, pure and simple." Shiff, *Cezanne and the End of Impressionism*, p. 121.

116. Jean-François Lyotard, *Des dispositifs pulsionnels* (Paris: Christian Bourgeois, 1973), pp. 79–80.

117. See the extended explication of the "Project" in Raymond E. Fancher, *Psychoanalytic Psychology: The Development of Freud's Thought* (New York: Norton, 1973), pp. 63–96.

118. See Paul Ricoeur, *Freud and Philosophy: An Essay on Interpretation*, trans. Denis Savage (New Haven: Yale University Press, 1970), pp. 130–131. In Ricoeur's lucid account of the "Project" in relation to Freud's subsequent psychoanalytic thought, he traces a shift from the diagramming of "an economy of bare forces" to a decipherment of "forces in search of meaning." See also the convincing evaluation of the "Project" in Oliver Sacks, "Origins of Genius: Freud's Early Years," *Double Take* 14 (Fall 1998), pp. 119–126.

perception is essentially re-created by “cathexes of attention,” and he describes a process whereby attention reshapes an object of perception in terms of desires and wishes. That is, perceptions undergo “revisions” before becoming conscious sensations.¹¹⁹ The “Project” details how the whole subjective orientation of an individual to the world, cognitively or perceptually, is a product of the discernment of attention and its differential functioning, even if attention performs an essentially defensive role, to “warn” of the imminence of unpleasurable memory traces.¹²⁰

I introduce Freud’s work here not as part of another dubious Freudian reading of Cezanne but as one of the influential reconceptualizations of perception in the late 1800s, even at this pre-psychoanalytic phase. Without diminishing Freud’s singularity, it is useful to position his work within models of perception in the second half of the nineteenth century that develop the premises of subjective vision into richer, more elaborated accounts of the importance of memory, interest, and desire in perception. Helmholtz is exemplary here for the articulation of a perceptual system that is no longer fully an optics, by demonstrating the constitutive part played by memory in almost all perception (and important in wholly different ways for his “economic” models of energy exchange). But with Bergson and Freud in the mid-1890s, the anti-optical functioning of subjective perceptual experience receives sustained and original consideration as a nondirectional, acentric, multitemporal event. Perception no longer implies a subject-object relation, consisting of a punctually located subject and the *illumination* of external objects. It becomes a question of the fluctuating relation of forces immanent to the

119. “The outcome of attention will be that in the place of the perception, one or more memory cathexes will appear, connected by association with the initial neurone.” Sigmund Freud, “Project for a Scientific Psychology,” in *The Origins of Psycho-analysis*, trans. Eric Mosbacher and James Strachey (New York: Basic Books, 1954), p. 420.

120. Katherine Arens insists on the epochal importance of Freud’s formulation here: “When he links attention to physical perception (in its essence often unconscious) and to pathological thought (with repressions of both conscious and unconscious thought), Freud is able to tie together broadly the function of language, symbol systems, the paths of association of data, and the knowledge or error in which the organism stands with respect to the world in a model integrating biology and theory. . . . Through habituation, everyday information is processed without conscious attention. These habits of association establish everyday behavior, but also a ‘world view.’ This world view is shared and signified as the sets of data to which attention is habitually paid or not paid, and which receive designations as language in an experience community. In this, Freud’s extended model has connected the habits of the individual with the episteme or world view of an age, going beyond either Foucault or Thomas Kuhn.” Arens, *Structures of Knowing: Psychologies of the Nineteenth Century*, Boston Studies in the Philosophy of Science, 113 (Dordrecht: Kluwer Academic Publishers, 1989), pp. 307–308. See also the account of the “Project” as Freud’s attempt “to devise a purely mechanical theory of defense and repression . . . without having to assume the existence of an ‘observing’ ego,” in Frank J. Sulloway, *Freud: Biologist of the Mind* (New York: Basic Books, 1983), pp. 113–131.

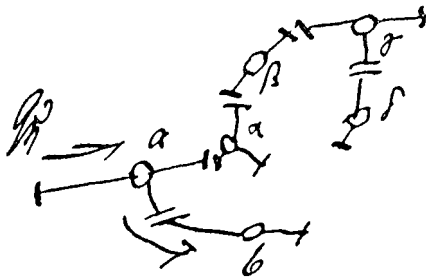
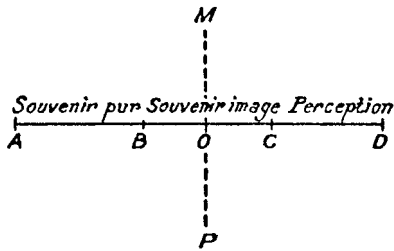

*Anti-optical models of perception:
diagrams from Bergson's *Matter and
Memory* and Freud's "Project for a
Scientific Psychology," 1890s.*

subject, and both Bergson and Freud attempted, albeit in decisively different forms, to work out the intricate network of interactions between present perception, the body, and memory. Both abandoned any sense of attentive perception as a finer and finer attunement of the subject to the contents of an external world, to an apprehension of presence. Bergson, of course, would have been dismayed by Freud's model of attention in the "Project," for it posed a subject radically removed from his ideal of an individual as an autonomous "center of indetermination." The concept of facilitation, which is central to the "Project," describes the grooving of pathways that were very much the kinds of habitual memories, recollections as merely repetition, which Bergson aspired to exceed. It is not that Freud outlined a deterministic model (and a case could be made that the "Project" describes an almost anarchical machinery of indetermination) but rather that his system is an automatic, self-regulating one, incompatible with Bergson's notions of freedom and decision.

Both Freud and Bergson at this time disclose how perception is constructed out of materials from multiple sources and locations. Freud's psychical topography

of pathways in the “Project” outlined the different directions from which excitatory materials flow into consciousness and the widely differing processes and “itineraries” that visual perceptions undergo within this mental system. Bergson diagrammed the process of perception in a way that precluded the idea of a point from which the presence of an image could be isolated. He proposed an intertwining of hypothetically distinct but inseparable processes in which the amalgamation of memory and perception was a continuous emergence of the actual from the virtual. What is in question is an emphatic decentering of the observer, a disruption of a merely receptive visual orientation to an exterior. But it is also important to recognize that the reconfiguration of vision and attention in thinkers like Freud and Bergson is not unrelated to pervasive assumptions in mainstream institutional psychology and physiology beginning in the 1880s. A British neurologist, writing in 1886, exemplifies a widespread anti-optical understanding of vision: “In your visual reflexes there is a regular jumble of sight, touch, hearing, the kinaesthetic sense, in fact of all the senses, with a few of the appetites, several distinct instincts, and the whole group of the higher faculties of reason, memory, judgment, attention, etc.—such a jumble, in fact, that *it is quite impossible to say where sight begins or where it ends*, or, in some of the reflexes, to see what sight has to do with them at all.”¹²¹ In this practical and discursive remaking of the observer as subject, vision is no longer a distinct and isolable phenomenon.

The plural composition of *Pines and Rocks*, its particular “jumble,” is relevant to one of the crucial hypotheses of Freud’s “Project.” Jacques Derrida emphasizes that already in 1895, Freud had defined the paradoxical operation of the psyche as “a potential for indefinite preservation and an unlimited capacity for reception.”¹²² That is, Freud tried to conceptualize how we simultaneously have the facility for *storage* of memories and the ability to receive new images free of the

121. W. J. Dodds, “On Some Central Affections of Vision,” *Brain* 8 (1886), p. 25; emphasis added. The aggregate nature of vision has been central to recent scientific accounts, for example in the work of Semir Zeki. He has shown how visual experience is a complex construction of distinct cortical centers, in which color, motion, and form are analyzed independently. See Zeki, “The Visual Image in Mind and Brain,” *Scientific American* 267, no. 3 (September 1992), pp. 69–76. See also Margaret Livingstone and David Hubel, “Segregation of Form, Color, Movement and Depth: Anatomy, Physiology and Perception,” *Science* 240 (May 6, 1988), pp. 740–749. Harvard neurologist M. Marsel Mesulam, beginning in the early 1960s, demonstrated that many different brain areas were involved in attention, that it is a “distributed process” involving sensation, movement, and emotion. Mesulam proposed that emotional interests, internal states of many kinds, determine what stimuli in a milieu will be selected by our attention. See his “A Cortical Network for Directed Attention and Unilateral Neglect,” *Annals of Neurology* 10 (1981), pp. 309–325.

122. Derrida, *Writing and Difference*, p. 222.

residue of earlier and now stored “traces.” Of interest here is Freud’s imaginary solution which Derrida describes as “a double system contained in a single differentiated apparatus: a perpetually available innocence and an infinite reserve of traces.” In *Pines and Rocks* the “volumetric” swath of the rocks is a system derived from convention, the residue of pictorial codes for representing objects and their relations, but it is also the site in the painting in which a sphere of habits, of repetitions or obsessions comes into play—where, in Freud’s words, “perceptions arouse interest on account of their possible connection with the object wished for,” that is, where perception is a question of *internal* excitation.¹²³ It would be pointless to read the image with any specificity beyond the general fragments of voluptuousness within the rocks, the sublime confinement of the pine tree at the left within the folds of the rock, the nestled, intimate contact of the two rocks in the middle, or the curves of the breast-shaped rock at the right, pointless to speculate on the identity of wished-for objects in the sedimentation of Cezanne’s psychic history.¹²⁴ But at the same time, as I tried to show earlier, this transversal, in spite of its scenic and libidinal overload, is only provisionally held together and in places spills over into the other zones of the work.

Cezanne, within a single work, diagrams the continuity or coexistence of an attentiveness that is bound (or cathected) onto established or facilitated patterns and a perception of anomalies and novelty. In *Pines and Rocks* the grip of the habitual and repetitive, the burden of one’s own history and its fixations, are at the same time the route into a relaxation of that grip. It is a move away from what Deleuze and Guattari call the “territorializing” function of memory to a becoming that is “an antimemory.”¹²⁵ This is not the same as the atemporal forgetting implicit

123. Freud, *The Origins of Psycho-analysis*, p. 423. Freud, in an astonishing passage, writes that “this state of attention has a prototype in the experience of satisfaction . . . and the repetitions of that experience, states of craving which developed into states of wishing and states of expecting. I have shown that these states contain *the biological justification of all thought*” (p. 418; emphasis added).

124. Coincidentally, Freud in the “Project” uses the example of a side view of a female breast in a discussion of the relation between a motor image and a “wishful cathexis”: “Suppose, for instance, that the memory-image wished for is—to take the case of a baby—an image of the mother’s breast with a front view of its nipple, but that the baby begins by having a perception which is a *side* view of the same object without the nipple. Now, he has in his memory an experience, made accidentally while he was sucking, of a particular movement of his head which changed the front view into the side view. Accordingly, the side image which he now sees leads to the head-movement, and an experiment will show him that the reverse of the movement must be performed and the perception of the front view will thus be obtained.” Freud, *The Origins of Psycho-analysis*, p. 391.

125. Gilles Deleuze and Felix Guattari, *A Thousand Plateaus: Capitalism and Schizophrenia*, trans. Brian Massumi (Minneapolis: University of Minnesota Press, 1987), p. 294. Also relevant is Deleuze and Guattari, *What Is Philosophy?*, trans. Hugh Tomlinson and Graham Burchell (New York: Columbia

in a “pure perception” but rather, as Meyer Schapiro showed, a temporality that is essentially musical. Again, it is Cezanne discovering or exploring, in his own way, the logic of attentiveness: of learning anew each time how his relentless enterprise of holding onto a visible world is doomed to disintegration and that within the efflorescences of these repeated failures is the entrance onto another space/time of rhythm, onto the indefinite floating time of an event “that knows only speeds and continually divides that which transpires into an already-there that is at the same time not-yet-here, a simultaneous too-late and too-early, a something that is both going to happen and has just happened.”¹²⁶

The upper area of the painting is especially important. Because of the assertive lattice structure of the pine trees, *Pines and Rocks* produces an effect of such formal clarity that one’s memory of the painting can easily include *four* trees instead of the three actually there. Even in its absence there is a latent sense that the upper part of the work is divided into five ‘panels’ or coequal intervals of foliage and sky. But the evaporation of that “logically” inferred pine tree is another facet of Cezanne’s affirmative unbinding of his attentiveness. In the large opening between the first tree at the left and the next one, there is a vertical white line, a suggestion of a small sapling positioned precisely where the “missing” trunk of the fourth pine should seemingly be. This hesitant upright inscription, instead of dividing the space into another legible interval, begins a new process of bifurcation, individuation, and metamorphosis of the sensory content within that region. Without the vertical trunk, the space there with its demotivated intermingling of line, color, and shadow, of blues and greens, unhinging them from a *motif*, is continuous with effects central to his landscapes of a few years later.¹²⁷ But here in the

University Press, 1994), pp. 166–168: “Memory, which summons forth only old perceptions, is obviously not enough to get away from lived perceptions; neither is an involuntary memory that adds reminiscence as the present’s preserving factor. Memory plays a small part in art (even and especially in Proust). It is true that every work of art is a *monument*, but here the monument is not something commemorating a past, it is a bloc of present sensations that owe their preservation only to themselves and that provide the event with the compound that celebrates it.” See the extended consideration of memory, intentionality, and perception in late nineteenth-century French landscape painting, in Joel Isaacson, “Constable, Duranty, Mallarme, Impressionism, Plein Air, and Forgetting,” *Art Bulletin* 76, no. 3 (September 1994), pp. 427–450.

126. Deleuze and Guattari, *A Thousand Plateaus*, p. 262.

127. The role of the color blue in *Pines and Rocks* (and late Cezanne in general) takes on additional significance through Julia Kristeva’s speculations on the likelihood that blue is perceived by the rods of the retina’s periphery, as opposed to the fovea which perceives stable forms. A possible hypothesis, she writes, “would be that the perception of blue entails not identifying the object; that blue is, precisely, on this side of or beyond the object’s fixed form; that it is the zone where phenomenal identity vanishes. . . . All colors, but blue in particular, would have a noncentered or decentering effect, lessening both object identification and phenomenal fixation. They thereby return the subject to the archaic moment of its dialectic, that is, before the fixed, specular ‘I,’ but while in the process of becoming this

disjunct makeup of this image, we can see a loosening of a perceptual grip that points toward a more intensive disorientation and a rhythmic contraction and expansion of the surface.¹²⁸ That the disintegration of this structurally implied tree occurs in the center of the painting is part of Cézanne's reversal of conventional models of foveal clarity and peripheral vagueness. The desynthesizing of the world which he develops in this area depends on the extraordinary "logic" of the strokes that constitute it—strokes that autonomously mutate, that disorganize themselves outside of any subjective unity or spatial coherence.

One key feature of Cézanne's landscapes from the early 1900s is evident in this central area of *Pines and Rocks*: the eradication of any *consistent* distinction between near and far vision, between what have sometimes been referred to as haptic and optic perception (I am following Gilles Deleuze's appropriation of Riegl's terms, where haptic refers to the eye-fulfilling "non-optical functions," including tactility but other senses as well, and where optic refers to a distant vision with a relative constancy of orientation and invariance of distance through static points of reference).¹²⁹ There is no longer any spatial schema in Cézanne's work that allows those distinctions to retain their coherence; instead his surfaces are assembled unpredictably out of the enigmatic palpability of distant forms and the evanescence of seemingly near-at-hand objects. The relations of scenic space are abandoned amid a new oscillation between close and distant vision, or between focus and out of focus. Philosopher Henri Maldiney, discussing Cézanne, characterizes such effects as a primal experience of vertigo, "an inversion and contamination of near and far. . . . The sky collapses along with the earth in a whirling. Man is no longer a center and space not a place. There is no longer a *there*. Vertigo is the auto-movement of chaos."¹³⁰ For all their differences, Cézanne's work and cinema both posed the possibility of what Deleuze described as an acentric ensemble of variable elements that act and react on each other. It is the idea of cinema as "the image of an open totality, at once moving and nonorientable, where the tem-

'T by breaking away from instinctual, biological (and also maternal) dependence." Kristeva, *Desire in Language: A Semiotic Approach to Literature and Art*, ed. Leon S. Roudiez, trans. Thomas Gora, Alice Jardine, and Leon S. Roudiez (New York: Columbia University Press, 1980), p. 225.

128. Yve-Alain Bois identifies an "aerated respiration" operating in late Cézanne. "I would even go so far as to say that his works are themselves lungs, that they breathe." "Cézanne: Words and Deeds," *October* 84 (Spring 1998), pp. 31–44.

129. Deleuze and Guattari, *A Thousand Plateaus*, pp. 492–496. See also the discussion of tactility in Richard Shiff, "Cézanne's Physicality: The Politics of Touch," in Salim Kemal and Ivan Gaskell, eds., *The Language of Art History* (Cambridge: Cambridge University Press, 1991), pp. 129–180.

130. Henri Maldiney, *Regard, parole, espace* (Lausanne: L'Age d'homme, 1973), p. 150.

porality enveloping us offers itself in its doubly contradictory dimension—incessant flux and instantaneous disjunction.”¹³¹

◆

The idea that Cézanne’s work constitutes a model of a nonhuman perception might seem to echo a theme present in analyses of the artist for nearly a century. How many times have we heard the echoes of Fritz Novotny’s assertion of Cézanne’s “distance from humanity,” of Kurt Badt’s claim that Cézanne portrays “a world infinitely remote from all human beings, a world unattainable by mankind and invulnerable to human intervention,” or the Spenglerian intonations of Hans Sedlmayr that “in its unnatural stillness it prepares for the eruption of the extra-human”?¹³² Of course there is also Merleau-Ponty’s identification of Cézanne as the artist who reveals “the base of inhuman nature.”¹³³ Usually such statements are made to serve readings of Cézanne’s work as an austere project of formal rigor, performed on some remote plane of aesthetic production or as an enterprise tragically detached from an engagement with the social contradictions of his time.

If, however, Cézanne’s late work is in some sense “nonhuman,” it is not because of its apparent remoteness from naturalist representational codes and their ideological underpinnings but because his experiments coincide historically with new perceptual technologies and thus, equally important, with a new set of *metaphoric* possibilities. We are told that, in the last years of his life, Cézanne often referred to himself as a “sensitized plate,” that he aspired to be a “recording machine,” and a “damned good machine.”¹³⁴ Despite the apparent photographic nature of this image of the plate, it does not seem as if such remarks were intended as a likening of the eye to a camera. In fact the organ mentioned in several of these remarks is the brain, not the eye. At one point, he specifies the sensitive plate of the artist’s “being.” What could be inferred here is the possibility of an *automatic* mode of operation that would exceed the obvious terms of a human-machine

131. Deleuze, *Cinema 1: The Movement-Image*, p. 61.

132. Fritz Novotny, “Cézanne and the End of Scientific Perspective,” in Judith Wechsler, ed., *Cézanne in Perspective* (Englewood Cliffs, N.J.: Prentice-Hall, 1975), p. 107; Kurt Badt, *The Art of Cézanne*, trans. Sheila Ann Ogilvie (London: Faber and Faber, 1965), p. 192; Hans Sedlmayr, *Art in Crisis: The Lost Center*, trans. Brian Batteshaw (London: Hollis and Carter, 1957), p. 134.

133. Merleau-Ponty, *Sense and Non-Sense*, p. 16.

134. The citations are from *Joachim Gasquet’s Cézanne*, trans. Christopher Pemberton (London: Thames and Hudson, 1991), pp. 148–154. Within some “empiricist” art historical studies, Gasquet’s reconstructions of his conversations with Cézanne remain controversial. My use of elements from these texts indicates my sense of their general authenticity and of their value as a historical resource. See the sensible assessment of this material in Christopher Pemberton’s “Translator’s Introduction,” in the above volume.

dichotomy. It is necessary to be able to think of a Cézanne who could imagine himself as a “double system,” a reservoir of historical and personal traces *and* a blank mechanical apparatus with an implacable functionality; a Cézanne who could, in one breath, insist that “prolonged work, meditation, study, suffering and joy . . . constant meditation on the methods used by the old masters” had all prepared him to become “a recording machine.” At this point in his life, all of that accumulated experience became the basis for a radical depersonalization from which he could intuit the creative forces of chaos, of an eternally returning cataclysm inscribed in matter, in the sky and rocks of his own Provence. Cézanne’s imaginary refiguration of himself as a “machine” which could “translate automatically” is an affirmation of his quest for a release from the grounded conditions of human perception; a quest to become an apparatus that could implacably apprehend a world outside of the terms of figure/ground, center/periphery, or close/distant.¹³⁵ And if, to suggest the novelty of such a machinic perception, Cézanne evoked a primordial image of the molten birth of the world, he would have done so only as the most available expression of an irreducible formlessness, of a world in process without horizons, without positions, a world only of vaporous, slowly vibrating color.¹³⁶ It might seem that Cézanne’s attraction to the glow of a geological dawn is a regressive pull toward the archaic, the inert, but this would miss the very “untimeliness” of his aspirations. Now in his sixties, he has little in common with the youthful Seurat’s fascination with a primal homeostasis. To become a “recording machine” is to overcome the gravity of one’s own interiority, one’s own

135. See the valuable comparison of Husserl and Nietzsche in John Rajchman, “The Earth Is Called Light,” *Architecture New York* 5 (March–April 1994), pp. 12–13. Husserl positions the body “in a single, unified kinesthetic field with receding horizons, which permits us to place things in a coordinate space, reidentify objects, and say what’s up and what’s down”; whereas for Nietzsche “the earth is precisely what cannot be delimited.” It is “unlimited, uncentered, formless.”

136. Gasquet’s account of Cézanne’s monologue includes: “Look at Sainte-Victoire there. How it soars, how imperviously it thirsts for the sun. And how melancholy it is in the evening when all its weight sinks back. . . . These blocks were made of fire and there’s still fire in them. . . . That’s what one needs to depict. What one needs to know. That’s the bath of experience, so to speak, in which the sensitized plate has to be soaked. In order to paint a landscape well, I first need to discover its geological structure. Think of the earth’s history as dating from the day when two atoms met, when two whirlwinds, two chemical dances, joined together. When I read Lucretius, I drench myself with those first huge rainbows, those cosmic prisms, that dawn of mankind rising over the void. In their fine mist, I breathe in the new-born world. I become sharply, overwhelmingly aware of color gradations. I feel as if I’m saturated by all the shades of the infinite. At that moment, I and my picture are one. Together we form a blue of iridescent hues. I come face to face with the motif; I lose myself in it. . . . I’d like to catch hold of this idea, this burst of emotion, this vapour of life hovering over the universal fire. My canvas begins to feel heavy; a weight is pressing on my brushes. Everything is falling. Everything is falling again below the horizon. From my brain onto the canvas; from my canvas to the ground. Heavily. Where is the air, where is that dense lightness? With genius, one could evoke the meeting of all these elements in mid-air, in the same ascent, the same desire.” *Joachim Gasquet’s Cézanne*, pp. 153–154.

intentionality, and Cézanne's remoteness here from Bergson is pronounced.¹³⁷ It is from the perspective of Cézanne's much-vaunted "isolation" of these last years (isolation of class, geography, community, old age) that his luminous Precambrian images of formlessness in fact corresponded to the deterritorializing processes of capitalism and its imperatives of perpetual renovation, to the uprooted, "nonorientable" subject who was compatible with its flows.

Paradoxically, it would have been Cézanne's own "conservatism," his avowed commitment to "the study of nature," that revealed to him not objects and their relations but a nature never distinct from his own sensations and drives, a nature that was experienced as vibrations, animations, and chromatic reverberations (even as he sought a "logic" to clarify their unfolding).¹³⁸ At the same time, it is easy to say that Cézanne's work could not have been more removed from the hodgepodge of effects associated with early cinema, which he likely never saw or thought about (except perhaps to excoriate it as a "hideous" sign of "progress" like the electric lights on the waterfront at L'Estaque, which so appalled him in 1902). But this is not the point, and, in relation to this question, Adorno is close to the mark: "The substantive element of artistic modernism draws its power from the fact that the most advanced procedures of material production and organization are not limited to the sphere in which they originate. In a manner scarcely analyzed by sociology, they radiate out into arenas of life far removed from them, deep into the zones of subjective experience, which does not notice this and guards the sanctity of its reserves."¹³⁹ Of course there is no demonstrable link between Cézanne and cinema, but their historical adjacency stands as a far more important

137. D. H. Lawrence, in the late 1920s, was one of the first to grapple with the demotivated subjectivity implicit in the late work: "Cézanne wanted something that was neither optical nor mechanical nor intellectual. . . . That is, he wished to displace our present mode of mental-visual consciousness, the consciousness of mental concepts, and substitute a mode of consciousness that was predominantly intuitive, the awareness of touch." Lawrence, "Introduction to These Paintings," in *Phoenix: The Posthumous Papers of D. H. Lawrence* (New York: Viking, 1972), p. 580. See the discussion of Lawrence's Cézanne criticism in Stephen Bann, *The True Vine: On Visual Representation and Western Tradition* (Cambridge: Cambridge University Press, 1989), pp. 73–77.

138. We know from Cézanne's correspondence of his admiration for Wagner's music, of his attending concerts of orchestral selections from various Wagner operas. Whether he ever heard extracts from *Tristan and Isolde* is uncertain. But Nietzsche's verbal distillation of the third act prelude from *Tristan* evokes the sense of a rhythmic systolic pulse that operates in the late work of Cézanne as well: "Suppose a human being has thus put his ear, as it were, to the heart chamber of the world will and felt the roaring desire for existence pouring from there into all the veins of the world, as a thundering current or as the gentlest brook, dissolving into a mist—how could he fail to break suddenly?" Nietzsche, *The Birth of Tragedy* (1872), trans. Walter Kaufmann (New York: Vintage, 1967), p. 127.

139. Theodor W. Adorno, *Aesthetic Theory*, trans. Robert Hullot-Kentor (Minneapolis: University of Minnesota Press, 1997), p. 34.

problem than, for example, his relation to cubism.¹⁴⁰ The late work of Cézanne, in spite of its singularity or the apparent social isolation of its production, is one of the sites in the late nineteenth century where a modernization of the observer occurs. Not only does Cézanne disclose the dissolutions that are inherent in the most rapt form of attention, but he heralds the same dynamization of perception occurring in many different domains around the year 1900, including the introduction of new techniques of vision. What he powerfully describes is not a logic of contemplative distance, of perceptual autonomy, but rather an account of a nervous system interfacing with a continually transforming external environment. Contemporary with early cinema, Cézanne's work in the 1890s involves a sweeping destabilization of what previously had constituted an "image." His work is one of numerous contemporary conceptualizations of reality as a dynamic aggregate of sensations. For both Cézanne and for the emerging industries of the spectacle, a stable punctual model of perception is no longer effective or useful.

By the late 1890s, as machinic visual technologies like cinema became widely known, they generally were not characterized as alien in any way to human vision. Instead cinema was hailed as an extension of existing forms of verisimilitude, with its own particular structures of empathy. Deleuze's work is important for explaining how cinema is fundamentally distinct from previous historical forms of simulation. It is not, as many continue to assume, part of some continuous Western mode of representation, with its origins in the Renaissance. Cinema, he writes, does not represent a world but constitutes an autonomous world, "made up of breaks and disproportion, deprived of all centers, addressing itself as such to viewers who are in themselves no longer the center of their own perception. The *perceptiens* and the *percipi* have lost their points of gravity."¹⁴¹ It is precisely the nonselectivity of the cinema eye that distinguishes it from the texture of a human attentiveness. Cinema, as it took shape during the last several years of Cézanne's life, is a contradictory form of synthetic unity in which rupture is also part of an unbroken flow of time, in which disjunction and continuity must be thought to-

140. See the consideration of the relation between early cinema and painting in Steven Z. Levine, "Monet, Lumiere, and Cinematic Time," *Journal of Aesthetics and Art Criticism* 36, no. 4 (Summer 1978), p. 441: "Nevertheless, if I acknowledge at the outset the utter difference to be discerned and to be maintained in a discussion of the arts of film and painting around 1895, two arts that shared a reliance on the image but not necessarily on its temporal extension, I equally must confess an attraction for those aspects of the two arts that shared a common will to form, at a moment of historical conjunction when the energies of each seem to have been highly invested in the desire to be like the other."

141. Deleuze, *Cinema 2: The Time-Image*, p. 37. See also the compelling characterization of the singularity of the cinematic image in Steven Shaviro, *The Cinematic Body* (Minneapolis: University of Minnesota Press, 1993), pp. 24–32.

gether.¹⁴² Cinema is the dream of the fusion, of the functional integrity of a world where time and space were being uncoiled into a manifold of proliferating itineraries, durations, and velocities. As numerous critics have suggested, film became a validation of the authenticity of the perceptual disorientations that increasingly constituted social and subjective experience.¹⁴³

But this kind of discussion is missing a certain historical concreteness. What kind of “reorientations” were evident in cinema in the first few years of the twentieth century? Let’s take a well-known example, the 1903 Edison Company production of Edwin S. Porter’s *The Great Train Robbery*, although the features in it which interest me probably could be located in many contemporary films, even from two or three years earlier.¹⁴⁴ Much of the recent critical analysis of this film has been about its *narrative* strategies and the temporalities of its cross-cutting.¹⁴⁵ I merely want to point out some of the implications of one short sequence of this film, in scenes 2, 3, and 4. (Edison Company advertising billed the film as “a thrilling story told in Fourteen Scenes.”) In scene 2, during which the bandits first board the train, our point of view is as if standing near the railroad tracks at a watering station, while a train enters the right side of the frame, stops, and then continues moving at roughly a forty-five-degree angle, like an orthogonal, to the screen. In the next scene, our position is suddenly inside and identical with the moving train itself, in the mail car where the actual robbery takes place. But now the train moves parallel to the screen, from left to right. Through the open side door of the mail car we see the “static” landscape outside the train rushing past in a blur. Thus from scene 2 to scene 3 there is a complete exchange of positions and vectors, from an occupation of a stable ground against which the train-objectile moves, to a scene where this

142. See the discussion of this aspect of film in Marie-Claire Ropars-Wuilleumier, “The Cinema, Reader of Gilles Deleuze,” in Constantin V. Boundas and Dorothea Olkowski, eds., *Gilles Deleuze and the Theater of Philosophy* (New York: Routledge, 1994), pp. 255–260.

143. See, for example, Siegfried Kracauer, “The Cult of Distraction,” in *The Mass Ornament: Weimar Essays*, trans. Thomas Y. Levin (Cambridge: Harvard University Press, 1995), p. 326: “Here, in pure externality, the audience encounters itself; its own reality is revealed in the fragmented sequence of splendid sense impressions.”

144. On the larger institutional, aesthetic, and social background of this film and Porter’s work, see Charles Musser’s indispensable *Before the Nickelodeon: Edwin S. Porter and the Edison Manufacturing Company* (Berkeley: University of California Press, 1991). “*The Great Train Robbery* is a remarkable film not simply because it was commercially successful or incorporated American myths into the repertoire of screen entertainment, but because it presents so many trends, genres, and strategies fundamental to cinematic practice at that time” (p. 254). See also the insistence on the reciprocal remaking of spectatorship by cinema and railroad travel in Lynne Kirby, *Parallel Tracks: The Railroad and Silent Cinema* (Durham: Duke University Press, 1997).

145. See, for example, André Gaudreault, “Detours in Film Narrative: The Development of Cross-Cutting,” in Thomas Elsaesser, ed., *Early Cinema: Space, Frame, Narrative* (London: BFI, 1990), pp. 133–152; and Noel Burch, “Porter, or Ambivalence,” *Screen* 19, no. 4 (Winter 1978/1979), pp. 91–105.



Stills from Edwin S. Porter, The Great Train Robbery, 1903.

literally moving projectile, with which our own position is identified, becomes the “ground” against which the earth shoots past, unrecognizable in its rush or “whirling.” Then in the next scene we are abruptly *on top* of the still moving train, but now it moves directly into the frame on a trajectory *perpendicular* to the screen. Here both the train and the landscape through which it moves become intertwined as reversible, mutually conditioned lines of flight, the recession of one inseparable from the advance of the other. Directions—whether diagonal, horizontal, or vertical—cease to have any privileged significance within the nonhierarchical unfoldings of this spatial system. We are a long way from Merleau-Ponty’s account of symbolic behavior in which the horizon has a foundational priority in the structure of figure-ground in human perception.

In this brief (two minutes and twenty seconds) part of the film, we can identify what is of course a larger process of perpetual displacement and re-creation of positions and relations. It is hardly a question of a mobile point of view, but instead the serial reconfiguration of a kinesthetic constellation of moving forces, in which the idea of a coherent subject position is as irrelevant as the idea of Cartesian coordinates in a kaleidoscope. And I have given just the barest outline of a complex dynamic-kinetic framework, within which additional systems of movements and forces operate—of bodies, bullets, an explosion (which in some prints of the film was tinted red and orange). It is within these new conditions of perceptual experience that Deleuze, for example, stresses the conceptual proximity of Cezanne and the Russian filmmaker Dziga Vertov. Cezanne, he notes, was the first to imagine constructing an eye “which would be in things,” an eye that could record “universal variation, universal interaction.”¹⁴⁶ Similarly, Liliane Brion-Guerry has proposed conceptual correspondences between Cezanne’s late work and the “perpetual variation” in Schoenberg’s tonal experiments.¹⁴⁷

146. Deleuze, *Cinema 1: The Movement-Image*, p. 81. Vertov’s account of his own project is relevant in terms of its conceptual affiliations with aspects of Cezanne’s earlier experiments: “I am a mechanical eye. I, a machine, show you the world as only I can see it. Now and forever, I free myself from human immobility, I am in constant motion, I draw near, then far away from objects, I crawl under, I climb onto them . . . I plunge and soar together with plunging and soaring bodies. Now I, a camera, fling myself along their resultant maneuvering in the chaos of movement, recording movement, starting with movement of the most complex combinations.” Dziga Vertov, *Kino-Eye: The Writings of Dziga Vertov*, ed. Annette Michelson (London: Pluto Press, 1984), p. 17.

147. Liliane Brion-Guerry, “The Elusive Goal,” in Rubin, ed., *Cezanne: The Late Work*, p. 81: “Just at the moment when painting was to tend toward the expression of something beyond the figure, since it is with this possible infinite extension of reality that the artist is concerned, music likewise evolved toward the rejection of the particularizing function of a given tone. . . . This search for a unified space in which all things are open to each other, without either limits or bonds, this approach to a beyond that might be without restrictions . . . is quite different from the glorification of form for its own sake that characterizes the Cubist aesthetic.”

Clearly there were many places in the late 1890s and very early years of the twentieth century where the subject was being reconfigured in terms of its dynamic sensorimotor interaction with a continually *modulating* lived environment. In the years between 1895 and 1900, the British neurologist Charles Scott Sherrington formulated one of the most influential modern accounts of the human nervous system, an account that coincides with the spread of increasingly kinetic and dynamic environments of technological urban culture in the West, with “the space-conquering phase” of modernity (to use Simmel’s phrase) from the 1890s up to the mid-twentieth century.¹⁴⁸ Part of Sherrington’s task was to explain the human organism’s capacity to integrate in a functional and practical way the overwhelmingly complex amount of sensory information in a given milieu. What was it that guaranteed orderly and coherent action in the face of a continually changing field of sensation? Sherrington’s model of the human subject, which became a powerful component of institutional knowledge about human behavior in the early twentieth century, effectively declared that perception and physical action were inseparable, that the two did not exist autonomously.

Sherrington’s cultural importance (he is often identified as one of the greatest neurologists of all time) is to have provided an alternative model within the behavioral sciences to Pavlov’s atomized conception of reflex functioning, even though his work is in one sense the fulfillment of the nineteenth-century research on inhibitory mechanisms discussed in connection with Seurat.¹⁴⁹ Georges Canguilhem believes Sherrington’s work stands for the general renunciation of the idea of the reflex as a one-to-one relation between a punctual stimulus and an isolated muscular response.¹⁵⁰ In brief, Sherrington sought to explain how the nervous system, composed of countless reflex actions, produced unified, coordinated motor behavior in animals or humans.¹⁵¹ But he treated behavior as an adaptive perfor-

148. Sherrington’s research was summarized in his major work, *The Integrative Action of the Nervous System* (New York: Scribner’s, 1906), but his “essential discoveries” were made between 1895 and 1900, according to Marc Jeannerod, *The Brain Machine: The Development of Neurophysiological Thought*, trans. David Urien (Cambridge: Harvard University Press, 1985), p. 44. See also the summary of Sherrington’s work in Roger Smith, *Inhibition: History and Meaning in the Sciences of Mind and Brain* (Berkeley: University of California Press, 1992), pp. 179–190.

149. Unlike Pavlov and his followers who insisted on “the simple reflex” as the essential unit of study, Sherrington asserted that the idea of single reflex action was “a fiction.” In a much-quoted introductory passage to *Integrative Action*, he wrote that the simple reflex “is probably a purely abstract conception, because all parts of the nervous system are connected together, and no part is probably ever capable of reaction without affecting and being affected by various other parts.”

150. Georges Canguilhem, “Le concept de reflexe au XIXe siecle,” in *Etudes d’histoire et de philosophie des sciences* (Paris: J. Vrin, 1983), p. 302.

151. In Sherrington’s holistic theory, “the actual reality is the sum total of the reflexes, since each single one is codetermined by the other reflexes. This sum represents the instrument of order which governs

mance of the body to a milieu, involving connectedness and decision, not simply reaction.¹⁵² One of the lasting implications of his research was that stimuli in the external world were not just alien shocks encountered and responded to but were in fact selected and even fashioned by the organism.¹⁵³ This more global understanding of behavior is foreshadowed by James's persistent defense of free will in the face of mechanistic explanations. In 1890 James had declared that "the whole drama of the voluntary life hinges on the amount of attention, slightly more or slightly less, which rival motor ideas may receive. But the whole feeling of reality, the whole sting and excitement of our voluntary life, depends on our sense that in it things are *really being decided* from one moment to another, and that it is not the dull rattling off of a chain that was forged innumerable years ago. This appearance, which makes life and history tingle with such a tragic zest, *may* not be an illusion."¹⁵⁴

Sherrington detailed how an organism's functioning involved the ceaseless transformation of perceptual information into purposeful action within the world. His emphasis on the kineto-temporal character of perceptual experience effectively annuls the notion of seeing "images" of the world, and uses (as did James)

the activity of the organism. The activity of the organism is guaranteed through the synergy of the reflexes which appears as a sum of numerous parts, which latter, regarded in isolation, do not exist at all, because they are merely abstractions. Order is established by the fact that this complicated reflex apparatus becomes active, and is kept active, through the total stimulation of the environment." Goldstein, *The Organism*, p. 89.

152. For Sherrington, "muscle movements are not a summation of reflexes but the meaningful behavior of a live organism in an environment or situation." Karl Jaspers, *General Psychopathology*, trans. J. Hoening and Marian Hamilton (Chicago: University of Chicago Press, 1963), p. 157.

153. Maurice Merleau-Ponty reluctantly credited Sherrington with demonstrating that "the classical reflex is an abstraction" and that his "great merit" was to have generalized the idea of inhibition within the global situation of the nervous system. But Merleau-Ponty insisted that Sherrington's project, finally, was "to save the principles of classical physiology," and that there is a fundamental disjunction between his categories and the *phenomena* he brought to light. Merleau-Ponty, *The Structure of Behavior* (1942), trans. Alden L. Fisher (Boston: Beacon Press, 1963), pp. 24–32. For a very different and more affirmative assessment of Sherrington, see Georges Thines, *Phenomenology and the Science of Behavior: An Historical and Epistemological Approach* (London: Allen & Unwin, 1977), pp. 82–95. Thines argues for Sherrington's proximity to scientific analyses derived from Gestalt theory and phenomenology, and he assesses the historical consequences of the ascendancy of Pavlov's model of the central nervous system in the early twentieth century rather than Sherrington's. Thines claims that Sherrington's experiments "define the framework of a psychology in which theoretical inferences rely on observations of behavior patterns *and* of corresponding nervous mechanisms. The latter are not mere entities as in classical reflexology, because they are related to the bodily structure of the behaving organism. This in turn leads to the study of the subjective world which corresponds to the organism's founding activity. This activity of subjectivity is called 'constitution' in Husserlian terminology" (p. 95).

154. James, *Principles of Psychology*, vol. 1, p. 453. James is situated within a general frame of late nineteenth-century "mystical positivism" in Terry Eagleton, "The Flight to the Real," in Sally Ledger and Scott McCracken, eds., *Cultural Politics at the Fin de Siecle* (Cambridge: Cambridge University Press, 1995), p. 14: "The pragmatism of a William James seeks to dethrone the tyranny of the rational concept, stripping it to a mere function or device by which we can move as efficiently as possible from this to that bit of our experience."

the word “stream” to describe how the flow and direction of energy within the nervous system change from instant to instant. At the same time he also employs the (Baudelairean) image of the kaleidoscope and other nineteenth-century technological imagery to suggest how changes in the contents of a perceptual field are never just incremental alterations but involve a total reorganization of response:

As a tap to a kaleidoscope, so a new stimulus that strikes the receptive surface causes in the central organ a shift of functional pattern at various synapses. . . . The gray matter may be compared with a telephone exchange, where, from moment to moment, though the end points of the system are fixed, the connections between starting points and terminal points are changed to suit passing requirements, as the functional points are shifted at a great railway junction. In order to realize the exchange at work, one must add to its purely spatial plan the temporal datum that within certain limits the connections of the lines shift from minute to minute.¹⁵⁵

This remarkable hybrid attempt to conjure a suitable four-dimensional image is meant to illustrate the uninterrupted modulation in which certain regions of the nervous system are “shut out” while “vast other regions” are called into play, all in the interest of maintaining the ongoing unity of the individual and of supporting what Sherrington refers to as “the great psychical process of attention.”¹⁵⁶

His work, as a study of behavioral structures, demonstrated an indissoluble and dynamic relation between perception and physical movement. His account of the nervous system in higher animals as a rich interface with an environment emphasized the extraordinarily intricate way in which sensory information of many different kinds is instantly processed in the form of organized motor responses to that information. It is known that Sherrington borrowed certain graphic recording techniques from Etienne-Jules Marey in the late 1880s, but if the work of Sherrington and Marey is to be associated historically it should be in terms of a larger social preoccupation with a rationalization of complex coordinated motor

155. Sherrington, *Integrative Action of the Nervous System*, pp. 232–233.

156. *Ibid.*, p. 234. The similarities between Freud and Sherrington in the 1890s are discussed in Karl H. Pribram, “The Neurophysiology of Sigmund Freud,” in Arthur J. Bachrach, ed., *Experimental Foundations of Clinical Psychology* (New York: Basic Books, 1962), pp. 442–468. Sherrington’s neurone hypotheses, like Freud’s early work, involve a mechanism of nervous conduction, with functions of accumulation, diffusion, and discharge.

behavior in living organisms.¹⁵⁷ Sherrington made a fundamental distinction between what he called “distance receptors,” which included vision, hearing and smell, and “immediate receptors,” which were the senses of taste and touch. Vision, as part of the evolution of biological survival mechanisms, was the primary “distance receptor” which allowed an organism to extend the limits of its subjective experience beyond its physical boundaries.¹⁵⁸ Sherrington’s work, like Bergson’s, disclosed a human perceiver for whom there could never be a pure or autonomous vision—vision did not exist apart from either volitional or instinctive movement, and clearly even a state of inhibition seemingly characterized by immobility (such as the rapt attentiveness of an artist like Cezanne) was maintained through a complex pattern of motor activity. One of Sherrington’s students reflected that his greatest single achievement was his reconceptualization of inhibition: “It is hard now to realize the great difficulty at the beginning of establishing that inhibition is an *active* process, and not a mere absence of activity.”¹⁵⁹ For Sherrington human vision could not be considered in isolation from the intricate relation of motor behavior to the “137 million separate ‘seeing’ elements spread out in the sheet of the retina.” The eye moving across a visual field was, he showed, dynamically interconnected “with wide tracts of musculature as a whole.”¹⁶⁰

Although vision in higher animals was what made possible *anticipatory* behavior and lengthened the response time to a stimulus, it ultimately was indistinguishable from exploratory locomotor behavior, from the mobility of the organism

157. See Judith P. Swazey, *Reflexes and Motor Integration: Sherrington’s Concept of Integrative Action* (Cambridge: Harvard University Press, 1969), p. 57. For an overview of Sherrington’s life and career, see the study by one of his students, Ragnar Granit, *Charles Scott Sherrington: An Appraisal* (London: Thomas Nelson and Sons, 1966).

158. See Sherrington, *Integrative Action of the Nervous System*, pp. 324–329. The capacity to perceive at a distance had been part of evolutionary explanations of animal and human behavior, especially in the work of Herbert Spencer.

159. D. Denny-Brown, “The Sherrington School of Physiology,” *Journal of Neurophysiology* 20 (1957), p. 546.

160. Sherrington, *Integrative Action of the Nervous System*, p. 234. Later in his career, Sherrington was able to make this astonishing characterization of vision: “Wonder of wonders, though familiar even to boredom. So much with us that we forget it all our time. The eye sends, as we saw, into a cell-and-fibre forest of the brain throughout the waking day continual rhythmic streams of tiny, individually evanescent, electrical potentials. This throbbing streaming crowd of electrified shifting points in the spongework of the brain bears no obvious semblance in space-pattern, and even in temporal relation resembles but a little remotely the tiny two-dimensional upside-down picture of the outside world which the eye-ball paints on the beginnings of its nerve-fibres to the brain. But that little picture sets up an *electrical storm*. And that electrical storm so set up is one which affects a whole population of brain-cells. Electrical charges having in themselves not the faintest elements of the visual—having, for instance, nothing of ‘distance’, ‘right-side-upness’, nor ‘vertical’, nor ‘horizontal’ nor ‘colour’, nor ‘brightness’,—yet conjure all of these.” Sherrington, *Man on His Nature* (Cambridge: Cambridge University Press, 1940), p. 113; emphasis added.

in the world. What intrigued Sherrington was something that remains a “deep problem” for late twentieth-century neuroscience, the problem of “binding”: that is, how coherent perceptions arise, how the nervous system has the capacity to synthesize stimuli of radically different sense modalities, from widely distinct spatial locations, into a seamless unfolding of motor activity.¹⁶¹ This was the “integrative function” of the nervous system that Sherrington studied so thoroughly. Perception is always an amalgam of information from “immediate” tactile receptors and “distant” optical and auditory receptors, and distinctions between the optical and the tactile cease to be significant (or could only have significance for an impossibly motionless subject with no lived relation to an environment). Vision as an “autonomous” process or exclusively optical experience becomes an improbable fiction.

Any remnants of a Cartesian notion of *res extensa* and *res cogitans* collapse decisively in Sherrington’s model—distance receptors effectively abolished physical distance by effecting a full incorporation of the exterior world. The interface that Sherrington describes renders the conventional sense of the physical boundaries of the organism meaningless. What is perhaps most important for my larger discussion is the articulation of a model of the human subject in which perception is no longer conceived in terms of a classical model of acquiring knowledge but is instead synonymous with the possibilities of motor activity. But it is motor activity advancing toward and in some way constructing a perpetually open future of proliferating possibilities and choices.¹⁶² At the same time it is a model of a subject capable of a *creative* as well as an efficient and productive interface with the dynamic and mobile complexity of a modernizing lifeworld.



As a way of developing these problems, I want to cite one of the most evocative excerpts from Cézanne’s entire correspondence, for how it suggests the importance of physical movement for his work. In a well-known letter to his son Paul in September 1906, just six weeks before his death, he writes:

Finally I must tell you that as a painter I am becoming more clear-sighted in front of nature, but that with me the realization of my sensations is always very difficult. I cannot attain the intensity that is

161. See Owen Flanagan, *Consciousness Reconsidered* (Cambridge: MIT Press, 1992), pp. 171–172.

162. For an important philosophical deployment of some of Sherrington’s concepts, see John Dewey, *Experience and Nature* (Chicago: Open Court, 1925), pp. 209–214. Dewey explores the lived consequences of “distance-receptors” to attack the notion that “matter, life and mind represent separate kinds of Being.”



Paul Cézanne, *Banks of a River*, c. 1904.

unfolded before my senses. I have not the magnificent richness of coloring that animates nature. Here on the edge of the river the motifs are very plentiful, the same subject seen from a different angle gives a subject for study of the highest interest and so varied that I think I could be occupied for months without changing my place, simply bending my head a little more to the right or left.¹⁶³

The temporality here is very much the time of the body, an indefinite scalar time—the present not as a moment extracted from time, but a moment that opens onto time—an atemporal present of the infinitive, in which the “intensity” unfolding chromatically before him is experienced as irrevocably outside representation, as an “animation” that is irrecuperable. What he calls his own “clear-sightedness” is

163. Paul Cézanne, *Letters*, ed. John Rewald (London: Cassirer, 1941), p. 262 (letter 193, September 6, 1906).

just this intuition of unattainability. That the motif in question is a river is not merely coincidental but stands for his engagement with a more primal flux. It is a mode of physical being in which familiar notions of stasis and movement are turned back onto one another. He posits an unchanging physical location but overlays onto it the idea of slight inflections and vacillations of position that generate a sustained condition of vibrating instability, what D. H. Lawrence called the “mysterious shiftiness” of the late landscapes.¹⁶⁴ The world for Cezanne is conceivable only as an indeterminate series of decenterings. It may be unnecessary to reiterate the obvious—that he is *not* accumulating different or multiple points of view of the same unified field. Rather it is an apprehension of a multiplicity in which points and relations are transformed qualitatively with each shift of his head, dissolving and reorganizing the world like turn of a kaleidoscope (the image used by both Sherrington and Bergson).¹⁶⁵ “What is simultaneous in a fixed system,” writes Deleuze, “ceases to be simultaneous in a mobile system.”¹⁶⁶ Cezanne’s intuitions here on the edge of the river can be affiliated with Nietzsche, who also recognized that “the world . . . is essentially a world of relationships; under certain conditions it has a differing aspect from every point; its being is essentially different from every point.”¹⁶⁷ For Cezanne too, it is not a question of simply intellectually grasping the idea of a plurality of perspectives but of experiencing how each perspective is a particular lived relation of forces, of intensities.

Whether or not Cezanne literally said he wanted to be like a “recording machine,” the fact remains that he was attempting, haltingly, doggedly, to make

164. D. H. Lawrence, “Introduction to These Paintings,” p. 92: Cezanne had an “intuitive feeling that nothing is really *statically* at rest . . . he could see the gradual flux of change. . . . And we realize with a sort of transport how intuitively *true* this is of landscape. It is *not* still. It has its own weird anima, and to our wide-eyed perception it changes like a living animal under our gaze.”

165. Bergson already understood the kind of dynamic events suggested in Cezanne’s letter, and he had recourse to the same kaleidoscope metaphor as Sherrington: “Here is a system of images which I term my perception of the universe, and which may be entirely altered by a very slight change in a certain privileged image—*my body*. This image occupies the center; by it all the others are conditioned; at each of its movements everything changes, as though by a turn of a kaleidoscope.” Bergson, *Matter and Memory*, p. 25.

166. Deleuze, *Bergsonism*, p. 79. Recent work in contemporary cognitive science provides a route back to the inseparability of vision and movement in Cezanne’s letter: “There are, for example, distinct effects produced by bodily tilt or auditory stimulation. Furthermore, the neuronal response characteristics depend directly on neurons localized far from their receptive fields. *Even a change in posture, while preserving the same identical sensorial stimulation, alters the neuronal responses in the primary visual cortex*, demonstrating that even the seemingly remote motorium is in resonance with the sensorium.” Francisco Varela, *The Embodied Mind: Cognitive Science and Human Experience* (Cambridge: MIT Press, 1991), p. 93; emphasis added.

167. Friedrich Nietzsche, *The Will to Power* (1888), trans. Walter Kaufmann (New York: Random House, 1967), sec. 568.

himself into a new kind of responsive, productive organ. Cézanne, around the turn of the century, incarnates a contradictory enterprise of self-transformation, of self-renewal. Through him we encounter the split phenomenon of a “grave attentiveness”: simultaneously a piercing social estrangement and a mode of unprecedented invention which imagined the radiant dissolution of the monadic confines of the self.¹⁶⁸ Of course Cézanne sensed the historical stakes of his experiments in terms of a retrospective fulfillment of a tradition from which he could not fully acknowledge his own decisive departure. But at the same time, the well-known phrases from his late letters about an end, a goal, a harbor all allude to a destination (or a homecoming) toward which a lifetime’s work was directed but whose actuality was not concretely discerned, except that, most palpably, it was still out of reach and the work itself incomplete. One must then at least consider the value of engaging these late landscapes as “anticipatory illuminations” of a possible future world, an illumination that always occurs in the midst of a recreation of the world.¹⁶⁹ Cézanne’s ironic reference to the “Promised Land” is a rare instance when his own private aspirations become tangible inversions of unthinkable and deferred collective dreams. His surface asociability and fearfulness mask the irreconcilable gap between his own visionary reformulation of the “natural” world and his broken hopes of community, intimacy, and Rousseauian open hearts. And as it was for the dejected Rousseau of the *Reveries*, Cézanne’s mode of attentive contemplation is a deliverance from the memory of suffering, a “compensation for human joys.”¹⁷⁰

168. In her important study of Rimbaud, Kristin Ross shows that one of the “disfigurements” inflicted under capitalism is “the closure of fields of socially available perception, the reduction not only of the environment of freedom but also of the very desire for and memory of that environment. Familiarity with capitalist culture persuades us that this limitation—the specific way people, their bodies, and their physical perceptions are organized within capitalism—is not historical but natural and physical. Yet the scope and manner of the mind’s attention, or of the body’s capacity for sensation, are social facts—and it is precisely the blindness and dullness peculiar to social relations in market society that enable us to deny the social and allow it to be subsumed in the biological.” Ross then indicates how Rimbaud responded to capitalist reification with images of “the more than human,” and of “the transformed utopian body of infinite sensation and libidinal possibility as figure for the perfected community, for associative or collective life.” Ross, *The Emergence of Social Space: Rimbaud and the Paris Commune* (Minneapolis: University of Minnesota Press, 1988), pp. 120–121. Cézanne and Rimbaud are evaluated as related models of “seers” in Philippe Sollers, *Le paradis de Cézanne* (Paris: Gallimard, 1995).

169. Ernst Bloch, *The Utopian Function of Art and Literature*, trans. Jack Zipes and Frank Mecklenburg (Cambridge: MIT Press, 1988), pp. 71–77.

170. Jean-Jacques Rousseau, *Reveries of a Solitary Walker* (1776), trans. Peter France (London: Penguin, 1979). In this text the ahistorical and asocial autonomy sought by Rousseau depends on an opposition of reverie and thought. “It was even to be feared that my imagination, alarmed by my misfortunes, might end by filling my reveries with them, and the continual consciousness of my sufferings might gradually come to oppress and crush me finally under their weight. In these circumstances an instinct that is natural to me averted my eyes from every depressing thought, silenced my imagination and,

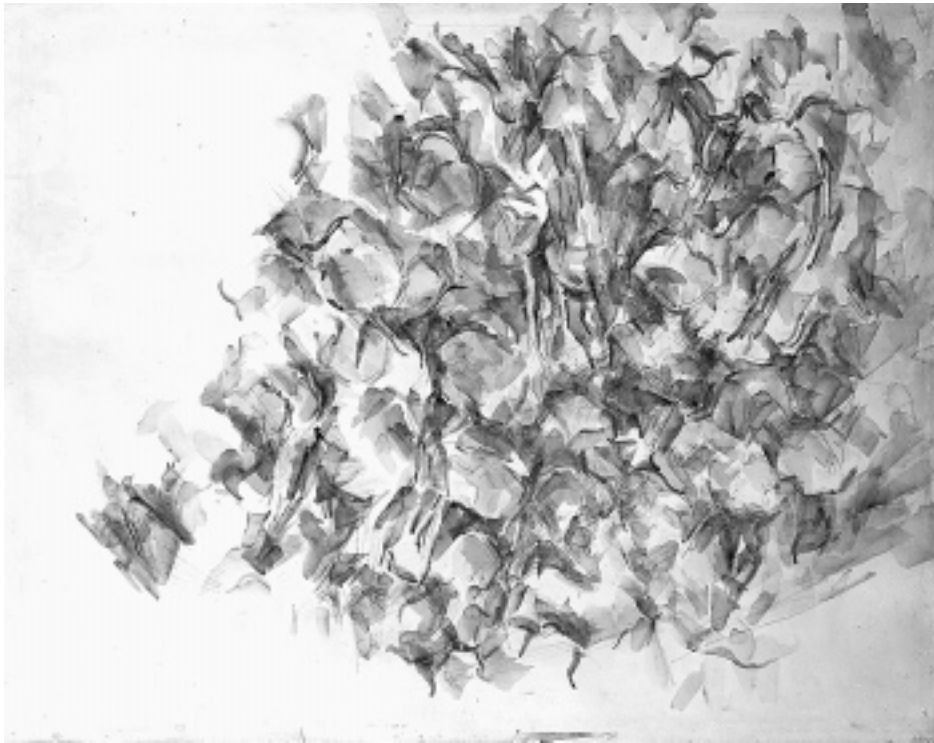

Paul Cézanne, Study of Foliage, watercolor, 1903.

It was in the course of making these most “modernized” works that Cézanne vehemently affirmed their continuity with the old masters, of their relation to the imaginary universe of the Louvre. In these late images, with their euphoric groundlessness, their pulsating chromatic fields, is an intimation of a libidinal release, of an intoxicating loss of self, which for Cézanne was mediated through the accumulated dream images of Arcadia, Cythera, or Rubens’s Gardens of Love.¹⁷¹ It is a dream that seeks to escape the sterility and banality of so many nineteenth-century images of “earthly paradises,” including the constricted locale of Manet’s *In the Conservatory*. But to identify the fragments of utopian content in Cézanne’s work

fixing my attention on the objects surrounding me, made me look closely for the first time at the details of the great pageant of nature. . . . The more sensitive the soul of the observer, the greater the ecstasy aroused in him by this harmony. At such times his senses are possessed by a deep and delightful reverie, and in a state of blissful self-abandonment he loses himself in the immensity of this beautiful order, with which he feels himself at one” (pp. 107–108).

171. These effects are realized most fully in the landscapes and watercolors rather than the more obviously historically self-conscious *Bathers*.

is not to impose on him the burden of a “utopian praxis.” His project will always remain far more ambivalent: as much as anything, his achievement was the production of novelty, both his radical redeployment of that cultural heritage for evocations of a sensory wholeness, and the novelty of a smooth, unorganized perceptual space, which is not fully distinct from one’s subjective relation to a realm of circulation and exchange. Cezanne’s work remains a preeminent example of the nonsynchronous character of modernism, of “the coexistence of realities from radically different moments of history.”¹⁷²

Thus part of Cezanne’s plural historical position is as the culmination and even termination of a romantic visionary tradition, going back to the late eighteenth century.¹⁷³ William Blake and Cezanne shared a related understanding of the universe as perturbations and differences between centers of energy. What Blake sought to achieve through a figurative language—an epic overcoming of gravity, of perceptual constraints and chromatic opacity—Cezanne realized in the transparent, ungrounded fields of his late watercolors and landscapes. The idea of an omnidirectional, perpetually modulating space (which some of Blake’s soaring, airborne figures incarnated) also opens up onto an early stage of twentieth-century modernization: this is the moment when the image as automatic self-movement, as a decentered chrono-iconography takes shape in many different places in the West.¹⁷⁴ Of course Cezanne’s images are static, but, no less than Marey’s, they diagram perceptual experience in constant transformation; the work of both intersects with temporal processes and motor responses that encompass but also exceed the exclusively optical. Cezanne’s late paintings surely fulfill and perhaps extravagantly exceed Bergson’s hypothesis of an “attention to life” in their disclosure of a world that resolves itself “into numberless vibrations, all linked together in uninterrupted continuity, all bound up with each other, and traveling in every direction like shivers through an immense body.”¹⁷⁵

172. Fredric Jameson, *Postmodernism, or the Cultural Logic of Late Capitalism* (Durham: Duke University Press, 1991), p. 307. Within the terms of Jameson’s argument, which works with Ernst Bloch’s notion of the “simultaneity of the non-simultaneous,” Cezanne’s art could be seen as drawing “its power and possibilities from being a backwater and an archaic holdover within a modernizing economy: it glorified, celebrated and dramatized older forms of individual production which the new mode of production was elsewhere on the point of displacing and blotting out.”

173. Meyer Schapiro specifically singles out *Pines and Rocks* as achieving “a visionary mood, a mystical immersion in nature’s depth.” Schapiro, *Cezanne*, p. 29.

174. See the evaluation of the new technological conditions of image making (including X rays, cinema, and chronophotography) and the subsequent reconceptualization of “seeing” in science and psychology, in Monique Sicard, *L’année 1895: L’image écartelée entre voir et savoir* (Paris: Empecheurs de penser en rond, 1994).

175. Bergson, *Matter and Memory*, p. 208.

Deleuze makes a valuable distinction between cinema and painting: because pictorial images are immobile in themselves, it is “the *mind* which has to make movement.”¹⁷⁶ The rise of cinema as a body-machine assemblage, he insists, poses a whole new paradigm of “psycho-mechanics.” For Deleuze, this industrial art coincides with a new “subjective and collective automaton,” and as such cinema is capable of “producing a shock to thought, communicating vibrations to the cortex, touching the nervous and cerebral system directly.” With it come two enormous spaces of possibility: on one hand the opening up of new experimental forms of life, of freedom and creation, in which Cezanne’s work also participated; on the other, the elaboration of countless procedures for the management of attention, which aspects of Seurat’s work had already suggested.¹⁷⁷ The first points to an affirmative model of automatic behavior (like Cezanne’s “recording machine”) in which thought functions at a higher level with an unprecedented arsenal of syntactic, perceptual, and conceptual tools. The second (implicit in cinema from the beginning) is a model of a passive automatism in which a subject “is dispossessed of his own thought, and obeys an internal impression which develops solely in visions or rudimentary actions (from the dreamer to the somnambulist, and conversely through the intermediary of hypnosis, suggestion, hallucination, obsession, etc.).”¹⁷⁸ As Deleuze, Benjamin, Virilio, and many others have shown, it was on this level that an art of automatic movement was to coincide with fascism, the organization of mechanized warfare, and with state propaganda of all kinds.

Cezanne’s work, however, precedes the concrete appearance of that second model, and it is the product of a transitional interval, an interregnum suffused with possibilities, after the uprooting of vision from the classical order of knowledge of the seventeenth and eighteenth centuries but before its thorough relocation in regimes of machine vision which take off in the twentieth century. Thus Cezanne’s

176. Deleuze, *Cinema 2: The Time-Image*, p. 156; emphasis added.

177. Steven Shaviro details these new material and psychic conditions of attentiveness: “The darkness of the movie theater isolates me from the rest of the audience, and cuts off any possibility of ‘normal’ perception. I cannot willfully focus my attention on this or on that. Instead, my gaze is arrested by the sole area of light, a flux of moving images. I am attentive to what happens on the screen only to the extent that I am continually distracted, and passively absorbed, by it. I no longer have the freedom to follow my own train of thought. . . . The unstable screen image holds my distracted attention captive; I do not have the ability to look away. There is no way to watch a film without allowing this to happen; I can resist it only by giving up on the film altogether, by shutting my eyes or walking out. But as I watch, I have no presence of mind: sight and hearing, anticipation and memory, are no longer my own. My responses are not internally motivated and are not spontaneous; they are forced upon me from beyond. Scopophilia is then the opposite of mastery: it is rather a forced, ecstatic abjection before the image.” Shaviro, *The Cinematic Body*, pp. 47–48.

178. Deleuze, *Cinema 2: The Time-Image*, p. 263.

work doesn't conform to the Francastel model of a "destruction" of a plastic space or to other related art historical models—rather it is about invention and novelty in a zone already opened up. It is the product of the turbulent activities of an eye that would overcome the monadic confines of human vision and be able to see with an impossible attentiveness, an eye without constraints, cut loose from its particular anchorage. He had no stake in improvising substitutes for an irrecoverable fixed point or axis from which the world might be arrested. Cézanne's late work attempts repeatedly to apprehend and achieve a liquid groundless space, filled with forces and intensities rather than objects, even as a related malleable and tractable visual space would become subject to endless forms of external restructuring, manipulation, and numbing standardization throughout the twentieth century. His relentless attentiveness to attention itself, his hovering at a threshold where revelation is inseparable from the onset of its dissolution, posed both the ground and the overcoming of the administered perception of spectacular culture for which attention would be made attentive to everything but itself.

EPILOGUE

1907: Spellbound in Rome

Ever to represent unto thyself, and to set before thee, both the general age and time of the world, and the whole substance of it. . . . Then to fix thy mind on every particular object of the world, and to conceive it, as it is indeed, as already being in the state of dissolution, and of change; tending to some kind of either decay or dispersion; or whatsoever else it is, that is the death as it were of everything in its own kind.

—Marcus Aurelius, *Meditations*

When William James wrote, sometime in the 1880s, his concise proposition, “My experience is what I agree to attend to,” he clearly meant it as an affirmation of an autonomous self-choosing, world-creating subject, liberated from the *receptive* status of a subject for whom experience was “the mere presence to the senses of an outward order.”¹ He certainly did not suspect that this equation might be an indication of a historical crisis in the nature of experience itself. That is, attention, as an indispensable part of an expanding terrain of modern spectacle, becomes both a simulation of and compensation for a chimerical “real” experience. As atten-

1. William James, *Principles of Psychology* (1890; New York: Dover, 1950), vol. 1, p. 402. James’s remoteness here from a Kantian problematization of experience is striking. For Kant, experience was only possible in terms of the “pure and a priori unity of the understanding.” “A mere empirical synthesis of perceptions” could not produce experience. Immanuel Kant, *Prolegomena to Any Future Metaphysics*, ed. Lewis White Beck (Indianapolis: Bobbs-Merrill, 1950), p. 57.

tion is posed as fundamentally constitutive of subjectivity, “experience” is increasingly resituated outside of collective, lived historical time.² For James, individual attentiveness to the fringes, transitions, pulses of one’s own particular “pure experience” was never effectively reconciled with “experience” as immersion in the tangled density of a shared, mutually inhabited world.³ In its overwhelmingly pervasive forms, modern attention will coincide with an individual evasion of both history and memory. Habitual and commodified, it becomes an imaginary deletion of all that is unbearable or intolerable in collective and individual experience. But for the ways in which attention is indispensable to the functioning of what Bataille calls homogeneous society, in which perceptual selectivity sustains usefulness and efficiency, attention is also, as I’ve tried to show, an opening onto a heterogeneous world of nonproductiveness, of decomposition: in itself, it leads to the ruin of certainties and stabilities. In the works I’ve examined by Manet, Seurat, and Cezanne, a sustained attentiveness was never fully separate from a tangled social and psychic machinery of sublimation; an absorbed perception, for each of them, was the disavowal, the evasion of a vision that laid bare an injured horizon of unfulfilled yearnings. Yet in its suspension, it also produced the conditions in which the apparent necessity and self-sufficiency of the present could be dissolved, allowing the anticipation of an ineffable future and also the redemption of the shimmering and derelict objects of memory.



As a way of concretely situating the dilemma figured in these artists’ works, I want to conclude with a somewhat different kind of artifact from those I have analyzed thus far: a brief text that richly illuminates some of the social and subjec-

2. Within the extensive recent critical literature on experience, see, in particular, Elizabeth J. Bellamy and Artemis Leontis, “A Genealogy of Experience: From Epistemology to Politics,” *Yale Journal of Criticism* 6, no. 1 (Spring 1993), pp. 163–184; Martin Jay, “Experience without a Subject,” in Michael Roth, ed., *Rediscovering History: Culture, Politics and the Psyche* (Stanford: Stanford University Press, 1994), pp. 121–136; and Edward S. Reed, *The Necessity of Experience* (New Haven: Yale University Press, 1996).

3. See William James, *Radical Empiricism and a Pluralistic Universe* (New York: Longmans, 1912), pp. 39–91, 277–300. “The rush of our thought forward through its fringes is the everlasting peculiarity of its life. We realize this life as something always off its balance, something in transition, something that shoots out of a darkness through a dawn into a brightness that we feel to be the dawn fulfilled. . . . In every crescendo of sensation, in every effort to recall, in every progress towards the satisfaction of desire, this succession of an emptiness and a fulness that have reference to each other and are one flesh is the essence of the phenomenon” (p. 283). Crucial here is James’s insistence on the self-canceling nature of experience, in which even the most traumatic events are dissolved into the primary reality of flux and insubstantiality. See the discussion of James’s conception of selfhood as private property, “the most radical of all possible alienation and disconnection,” in Frank Lentricchia, *Ariel and the Police* (Madison: University of Wisconsin Press, 1988), p. 118. But this very subjective isolation and separateness, Lentricchia insists, is deployed “to preserve a human space of freedom, however interiorized, from the vicissitudes and coercions of the marketplace.”

tive terrain I have moved across in this book, which at the same time hints at the transformations of this terrain to occur in the twentieth century. On September 22, 1907, Freud wrote a letter to his family from Rome, which I reproduce in full:

My dear ones

On the Piazza Colonna behind which I am staying, as you know, several thousand people congregate every night. The evening air is really delicious; in Rome wind is hardly known. Behind the column is a stand for a military band which plays there every night, and on the roof of a house at the other end of the piazza there is a screen on which a *societa Italiana* projects lantern slides. They are actually advertisements, but to beguile the public these are interspersed with pictures of landscapes, Negroes of the Congo, glacier ascents and so on. But since these wouldn't be enough, the boredom is interrupted by short cinematographic performances for the sake of which the old children (your father included) suffer quietly the advertisements and monotonous photographs. They are stingy with these tidbits, however, so I have had to look at the same thing over and over again. When I turn to go I detect a certain tension in the attentive crowd [der Menge aufmerksam], which makes me look again, and sure enough a new performance has begun, and so I stay on. Until 9 P.M. I usually remain spellbound [so der Zauber zu wirken]; then I begin to feel too lonely in the crowd, so I return to my room to write to you all after having ordered a fresh bottle of water. The others who promenade in couples or *undici, dodici* stay on as long as the music and lantern slides last.

In one corner of the piazza another of those awful advertisements keeps flashing on and off. I think it is called Fermentine. When I was in Genoa two years ago with your aunt it was called Tot; it was some kind of stomach medicine and really unbearable. Fermentine, on the other hand, doesn't seem to disturb the people. In so far as their companions make it possible, they stand in such a way that they can listen to what is being said behind them while seeing what is going on in front, thus getting their full share. Of course there are lots of small children among them, of whom many women would say that they ought to have been in bed long ago. Foreigners and natives mix in the most natural way. The clients of the restaurant behind the column and of the confectioner's on one side of the piazza enjoy themselves too; there are wicker chairs to be had near the music, and the townspeople like



Piazza Colonna, Rome, c. 1900.

sitting on the stone balustrade round the monument. I am not sure at the moment whether I haven't forgotten a fountain on the piazza, the latter is so big. Through the middle of it runs the Corso Umberto (of which it is in fact an enlargement) with its carriages and an electric *tranvia*, but they don't do any harm, for a Roman never moves out of a vehicle's way and the drivers don't seem to be aware of their right to run people over. When the music stops everyone claps loudly, even those who haven't listened. From time to time terrible yells are heard in the otherwise quiet and rather distinguished crowd; this noise is caused by a number of newspaper boys who, breathless like the herald of Marathon, hurl themselves onto the piazza with the evening editions, in the mistaken idea that with the news they are putting an end to an almost unbearable tension. When they have an accident to offer, with dead or wounded, they really feel masters of the situation. I know these newspapers and buy two of them everyday for five *centesimi* apiece;

they are cheap, but I must say that there is never anything in them that could possibly interest an intelligent foreigner. Occasionally there is something like a commotion, all the boys rush this way and that, but one doesn't have to be afraid that something has happened; they soon come back again. The women in this crowd are very beautiful (foreigners excepted); the women of Rome, strangely enough, are beautiful even when they are ugly, and not many of them are that.

I can hear the music plainly from my room; but of course I cannot see the pictures. Just now the crowd is clapping again.

Fond greetings, Your Papa⁴

One of the remarkable features of this epistle is how it discloses the transformed status of an observer even as it conveys a sense of the perpetually incomplete and partial modernization of experience. Freud presents to us an urban scene in which an individual and a collective subjectivity take shape in a multiplicity of images, sounds, crowds, vectors, pathways, and information, and his letter documents one particular attempt at cognitively managing and organizing that overloaded field. It provides a leisurely image outside of the Baudelaire/Simmel tradition of shock-ridden inner life with its "swift and continuous shift of stimuli." Freud's genial evocation of couples strolling and groups lounging in wicker chairs in the soft summer night air seems far removed from the neurasthenic edge of Simmel's 1903 essay on metropolitan life. Nor does this Rome seem to be a prime arena for the post-Haussmann flaneur, the isolated distracted spectator, moving along new urban routes, yielding to a continually changing stream of excitations.

This text situates its reader within an urban space that retains some important premodern features, at least in its superficial baroque formation.⁵ Unlike Seurat's bleak and vacant Place de la Concorde, the Piazza Colonna here conforms to what urban planner Camillo Sitte celebrated as a "hypaethral assembly hall": a site brimming with cosmopolitan vitality, with a festive, collective occupation of the city, even as a new kind of "audience" is disclosed amid the surrounding porticos and

4. *The Letters of Sigmund Freud*, ed. Ernst L. Freud, trans. Tania and James Stern (New York: Basic Books, 1975), pp. 261–263. The letter is also reproduced in a different English translation in Ernest Jones, *The Life and Work of Sigmund Freud* (New York: Basic Books, 1953–1957), vol. 2, pp. 36–37. Jones casually cites it as a "typical" letter written by Freud while traveling.

5. The Piazza Colonna had been significantly enlarged in 1889 but in a way that "preserved" much of its original architectural character and urban texture. It is one of the many places in which we witness the overlapping of urban form with the consumerist and antiquarian ambitions of the late nineteenth-century museum.

palazzos.⁶ However, in these historically sedimented confines, the city is transformed, not by physical demolition but by an internal mutation and reciprocal perceptual disintegration.⁷ Instead of setting its inhabitants in ambulatory motion, this modernized city-arena produces and engages a relatively sedentary spectator. There may be homelessness, but there is no agoraphobia or *Platztangst* in Freud's Piazza Colonna.⁸

The patchwork texture of screens and flashing signs (to "beguile the public") is a turning point in a long-term Piranesian dissolution of the axial city which had organized views around a coherent, even if mobile, subjective orientation.⁹ The magic lantern slides, the cinematic projections, and the electrically lit advertisements are only the more obvious elements of a formless field of attraction (already heralded in the surface of Seurat's *Parade de cirque*) which undermines the older monumental organization of the square. Its defining architectural facades and its central imperial column (with its own images of remote Roman victories over German tribes) give way to the evanescent lantern scenes of modern-day colonies and foreign landscapes. Freud, however, does not even indicate the content of the cinematographic performances. The demonstration of the technology itself is attraction enough, flickering images devoid of depth and torn away from any horizon. The dematerialization of architectural surfaces into projection screens signals the reversibility of what had been established figure/ground relations within an urban fabric, and the screen on these Roman rooftops effectively displaces the built city to the oblivion of a cognitive periphery. The blurring of coherent monumental landmarks is evident in Freud's doubts about his own representation of the piazza (not sure

6. Cited in George R. Collins and Christianne C. Collins, *Camillo Sitte and the Origins of Modern City Planning* (New York: Random House, 1965), p. 104.

7. I use the notion of sedimentation to suggest how the destructive transformations of modernization always preserve and carry over nonsynchronous components of past moments. Henri Lefebvre outlines this process in terms of modern urbanization: "Space as a whole, geographical or historical space, is thus modified, but without any concomitant abolition of its underpinnings—those initial 'points,' those first foci or nexuses, those 'places' (localities, regions, countries) lying at different levels of a social space." Lefebvre, *The Production of Space*, trans. Donald Nicholson-Smith (Oxford: Blackwell, 1991), p. 90.

8. See the important analysis of the emergence of "spatial pathologies" in the late nineteenth century, including a discussion of Simmel, in Anthony Vidler, "Psychopathologies of Modern Space: Metropolitan Fear from Agoraphobia to Estrangement," in Roth, ed., *Rediscovering History*, pp. 11–29.

9. Manfredo Tafuri situated the work of Piranesi as a harbinger of the logic of the modern urban form: "It is immediately apparent that this structure is composed of a formless heap of fragments colliding one against the other. . . . Not by accident does it take on the appearance of a homogeneous magnetic field jammed with objects having nothing to do with each other." Tafuri, *The Sphere and the Labyrinth: Avant-Gardes and Architecture from Piranesi to the 1970s*, trans. Pellegrino d'Acierno and Robert Connolly (Cambridge: MIT Press, 1987), pp. 34–35.

whether he had forgotten a fountain), and the next day he wrote a brief four-sentence correction to his family, letting them know that in fact there was a fountain.¹⁰ The screen not only dissolves a classical notion of a facade but is also part of a multidirectional field of stimuli, in which one can listen to a military band behind, observe lantern slides in front, and glimpse the crowd all around. It is an urban space which, in Colin Rowe's words, is simultaneously "a theater of memory and a theater of prophecy."¹¹

The strata of attentiveness suggested in this sketch of a nascent spectacular milieu must be seen in relation to one of the most formidable techniques of attention to emerge in the twentieth century, a method conceived by Freud and lying at the heart of his therapeutic enterprise. In a paper first published in 1912, Freud put forward some essential "technical rules" for analysts to follow. The first of these techniques is what Freud called "evenly suspended attention," which described a self-conscious strategy of "not directing one's notice to anything in particular and maintaining the same 'evenly suspended attention [gleichschwebende Aufmerksamkeit]' (as I have called it) in the face of all that one hears. In this way we spare ourselves a strain on our attention which could not in any case be kept up for several hours daily, and we avoid a danger which is inseparable from the exercise of deliberate attention."¹² Of course Freud is concerned here with the physiological and mental limits of a sustained attentiveness, and he specifies the particular semiotic overload an analyst must cope with, seeing possibly eight patients in a working day, listening to "all the innumerable names, dates, detailed memories and pathological products." But the fundamental significance of his remarks is the attempt to define a state of receptivity in the analyst that will be commensurate with the spoken free association of the patient. "It will be seen that the rule of giving equal notice to everything is the necessary counterpart to the demand that he should communicate everything that occurs to him without criticism or selection."¹³ In this sense, part of Freud's

10. On the complicated significance of Rome in Freud's life and thought, see David Damrosch, "The Politics of Ethics: Freud and Rome," in Joseph Smith and William Kerrigan, eds., *Pragmatism's Freud: The Moral Disposition of Psychoanalysis* (Baltimore: Johns Hopkins University Press, 1986), pp. 102–125.

11. Colin Rowe and Fred Koetter, *Collage City* (Cambridge: MIT Press, 1978), p. 49.

12. Sigmund Freud, "Recommendations to Physicians Practising Psycho-analysis," in *The Standard Edition of the Complete Psychological Works of Sigmund Freud*, trans. James Strachey (London: Hogarth Press, 1953–1974), vol. 12, pp. 111–112.

13. *Ibid.*, p. 112. A decade earlier, the Würzburg psychologist Oswald Kulpe had associated a defamiliarized and neutral attentiveness with artistic genius: "We say that a man shows genius when he discovers new aspects or new attributes where all the rest of the world have passed by unheeding. But

modernity is that he proposes a technique for dealing with a stream of information that has no evident structure or coherence. Laplanche and Pontalis describe Freud's formulation thus: "This consists in as complete a suspension as possible of everything which usually focusses the attention: personal inclinations, prejudices, and theoretical assumptions however well grounded they might be."¹⁴ Freud then, like Cezanne, designs a singular countermodel of attentiveness, one that resists the notion of selection and surmounts an inhibition of the peripheral. It presumes an ideal state in which one could redistribute one's attention so that *nothing* would be shut out, so that everything would be in a low-level focus but without the risk of schizophrenic overload.¹⁵ It is a full reversal of the "searchlight" hypothesis of attention, for that kind of illuminating "selection" carries the risk of finding only "what one already knows." Freud sought to fashion himself (the analyst) into an apparatus capable of engaging a seemingly random sequence of signs (whether language, gestures, intonations, silences) and yet extracting from that disjunct texture some interpretive clarity.¹⁶ My interest here is not in any specific psychoanalytic implications, but rather in the larger cultural significance of a technique designed to impose a measure of cognitive control on an unassimilable excess of information or on the apparently chaotic syntax of dreams. At stake is a calculated demotivation of attention, an automation of it, as a way of decoding the historical genesis of an indecipherable present, in terms of an individual human subject.

such discovery demands *an absolute impartiality of attentive observation*, and the freedom from current views and habitual prejudices." Kulpe, "The Problem of Attention," *Monist* 13, no 1 (October 1902), p. 59; emphasis added.

14. J. Laplanche and J.-B. Pontalis, *The Language of Psycho-analysis*, trans. Donald Nicholson-Smith (New York: Norton, 1973), p. 43.

15. As early as 1900, Freud had made a distinction between a critical and a diffuse attention. The former was a faculty in which an observer is led "to reject some of the ideas that occur to him after perceiving them, to cut short others without following the trains of thought which they would open up to him, and to behave in such a way towards still others that they never become conscious at all and are accordingly suppressed before being perceived." The latter model of attention, crucial both for patient and analyst, depended on "a reduction of critical activity" and was a "psychical state which, in its distribution of psychical energy (that is, of mobile attention), bears some analogy to the state before falling asleep—and no doubt also to hypnosis." Freud here cites Schiller's call for "a relaxation of the watch upon the gates of Reason." Freud, *The Interpretation of Dreams*, trans. James Strachey (New York: Avon, 1965), pp. 134–136.

16. Summarizing the analyst's technique, Freud offers one of his many images of a machine or apparatus to elucidate a given psychic process or intersubjective relation: "He must adjust himself to the patient as a telephone receiver is adjusted to the transmitting microphone. Just as the receiver converts back into sound waves the electric oscillations in the telephone line which were set up by sound waves, so the doctor's unconscious is able, from the derivatives of the unconscious which are communicated to him, to reconstruct that unconscious, which has determined the patient's free associations." Freud, "Recommendations to Physicians," p. 116.

However, in the larger *social* arena of the Piazza Colonna (and the parallel emergence of a *Massenpsychologie*), the operation of a related dispersal of attention does not even begin to make intelligible the shifting and disjunct urban field of collective subjects and events. The irrelevance of the Column itself, and the loss of all its mnemonic significance, is a sign of the installation of a new temporality which subsists as a dehistoricized perpetual present, wavering between boredom and absorption, between self-extinguishing immersion in the crowd and unbearable social solitude. The recurring appearance of the shouting newsboys, with each new edition of the newspaper negating the claims to importance of the previous one, are part of what Guy Debord saw as the eradication of historical consciousness in a society of the spectacle, “the ceaseless circularity of information, always returning to the same short list of trivialities, passionately proclaimed as major discoveries.”¹⁷ Freud’s experience of the cinematograph is especially important here: the idea that the same loop of film can be indefinitely repeated and each time render its audience “spellbound.”¹⁸ Repetition here is inseparable from the modern production of historical amnesia, and we can identify some of the origins of our own turn-of-the-century world in which the compulsory consumption of “information” is made synonymous with experience.

But as Freud writes: “Until 9 P.M. I usually remain spellbound; then I begin to feel too lonely in the crowd.” This state of fascinated absorption is not comprehensible apart from the sense of isolation that immediately follows. The particular occasion of the letter (a husband/father in a foreign city) situates it within a larger thematic of modern homelessness, but Freud’s pervasive tone of mild condescension points in another direction as well. Peter Stallybrass and Allon White conclude their fine account of the nineteenth-century rejection of carnival with the following observation: “There is no more easily recognizable scene of bourgeois pathos than the lonely crowd in which individual identity is achieved *over against* all the others, through the sad realization of not-belonging. That moment, in which the subject is made the outsider to the crowd, an onlooker, compensating for exclusion through

17. “When social significance is attributed only to what is immediate, and to what will be immediate immediately afterwards, always replacing another, identical, immediacy, it can be seen that the uses of the media guarantee a kind of eternity of noisy significance.” Guy Debord, *Comments on the Society of the Spectacle*, trans. Malcolm Imrie (New York: Verso, 1990), pp. 13–15.

18. That this repetitiveness can still be spellbinding for Freud, confirms Tom Gunning’s thesis that up to around 1907 cinema was essentially “exhibitionist,” that its attraction was the very display of its own visibility. It “directly solicits spectator attention, inciting visual curiosity, and supplying pleasure through an exciting spectacle—a unique event, whether fictional or documentary, *that is of interest in itself*.” Gunning, “The Cinema of Attractions: Early Film, Its Spectator, and the Avant-Garde,” in Thomas Elsaesser, ed., *Early Cinema: Space, Frame, Narrative* (London: BFI, 1990), pp. 57–58; emphasis added.

the deployment of the discriminating gaze, is at the very root of bourgeois sensibility.”¹⁹ The autonomy, the privacy that Freud seems to be arrogating for himself here (figured at the end of his letter by the insularity and sensory remove of his hotel room) is a futile evasion of the deindividuation which he experienced in the piazza and which impelled his retreat to a more controllable form of loneliness.

The dissolution of the axial, monumental city coincides with what Gianni Vattimo details as the onset of a world of multiple rationalities, a proliferation of images and communication, and the erosion of a principle of reality. To inhabit this pluralistic world, he says, means to endure a continual oscillation between belonging and disorientation, and in Manet's *Balcony* we saw an early incarnation of that rhythmic movement.²⁰ Paradoxically, to be “spellbound” in front of the cinematograph is both of these, immersed in a collectivity and simultaneously separated in absorptive solitude. Modern attention inevitably fluctuates between these poles: it is a loss of self that shifts uncertainly between an emancipatory evaporation of interiority and distance and a numbing incorporation into myriad assemblages of work, communication, and consumption. Thus the plural, hybrid space of this Roman square in late summer of 1907 foretells how spectacular society is not irrevocably destined to become a seamless regime of separation or an ominous collective mobilization; instead it will be a patchwork of fluctuating effects in which individuals and groups continually reconstitute themselves—either creatively or reactively. But even if the latter adverb may be applicable to the most catastrophic social “restitutions” in the twentieth century, on this particular September 22 the crowd of several thousand, even when spellbound, does not in the least resemble the regressive, docile masses of Le Bon or others. In the “delicious” evening air, the entrancing repetition of faintly glimmering images on a makeshift screen does not impede the spontaneous play of social aggregation within this enduring arena of conviviality and life.

19. Peter Stallybrass and Allon White, *The Politics and Poetics of Transgression* (Ithaca: Cornell University Press, 1986), p. 187.

20. Gianni Vattimo, *The Transparent Society*, trans. David Webb (Baltimore: Johns Hopkins University Press, 1992), p. 10.

Illustration Credits

Bildarchiv Preussischer Kulturbesitz: pp. 6, 91
Metropolitan Museum of Art, New York: pp. 7, 151, 187
Museum of Modern Art: pp. 8, 178, 329, 356
U.S. Department of the Interior, Edison National Historic Site: p. 32
Giraudon/Art Resource, New York: pp. 50, 82
Culver Pictures: p. 67
Bridgeman Art Library International: p. 69
Art Institute of Chicago: pp. 89, 180
Réunion des Musées Nationaux: pp. 103, 112, 114, 268, 277
Solomon R. Guggenheim Foundation: pp. 109, 185, 195
Philadelphia Museum of Art: p. 288

Bibliography

This bibliography lists cited texts from before 1910.

- Allen, Grant. *Physiological Aesthetics*. London: H. S. King, 1877.
- Angell, James R. *Psychology: An Introductory Study of the Structure and Function of Human Consciousness*. New York: Henry Holt, 1904.
- Angell, James R., and Addison W. Moore. "Reaction Time: A Study in Attention and Habit." *Psychological Review* 3 (1896), pp. 245–258.
- Aristotle. *The Complete Works of Aristotle*. Ed. Jonathan Barnes. 2 vols. Princeton: Princeton University Press, 1984.
- Augustine. *City of God*. Trans. Henry Bettenson. London: Penguin, 1972.
- Bache, P. Meade. "Reaction Time with Reference to Race." *Psychological Review* 2, no. 5 (September 1895), pp. 475–486.
- Baldwin, James Mark. *Handbook of Psychology: Feeling and Will*. New York: Henry Holt, 1891.
- Bastian, Charlton. "Les processus nerveux dans l'attention et la volition." *Revue philosophique* 32 (April 1892), pp. 353–384.
- Baudelaire, Charles. *Oeuvres complètes*. Paris: Gallimard, 1961.
- Baudelaire, Charles. *Selected Writings on Art and Artists*. Trans. P. E. Charvet. Harmondsworth: Penguin, 1972.
- Bergson, Henri. *Creative Evolution* (1907). Trans. Arthur Mitchell. New York: Random House, 1944.
- Bergson, Henri. *Matter and Memory* (1896). Trans. W. S. Palmer and N. M. Paul. New York: Zone Books, 1988.
- Bergson, Henri. *Time and Free Will: An Essay on the Immediate Data of Consciousness* (1888). Trans. F. L. Pogson. New York: Harper and Row, 1960.
- Bernard, Emile. "Paul Cezanne." *L'Occident*, July 1904, p. 20.
- Bernheim, Hippolyte. *Hypnosis and Suggestion in Psychotherapy* (1884). Trans. Christian Herter. New York: Aronson, 1973.
- Binet, Alfred. "Le fétichisme dans l'amour." *Revue philosophique* 25 (1888), pp. 142–167, 252–275.
- Binet, Alfred. *On Double Consciousness*. Chicago: Open Court, 1890.
- Binet, Alfred, and Charles Fere. *Le magnétisme animal*. Paris: Felix Alcan, 1888.
- Blanc, Charles. *Grammaire des arts du dessin* (1867). Paris: H. Laurens, 1880.
- Bolton, Thaddeus. "Rhythm." *American Journal of Psychology* 6, no. 2 (January 1894), pp. 145–238.
- Bonnier, Charles and Pierre. "Documents et critique expérimentale: Parsifal." *Revue wagnérienne* 2 (March 1887), pp. 42–55.
- Bradley, F. H. "Is There Any Special Activity of Attention?" *Mind* 11 (1886), pp. 305–323.

- Bradley, F. H. "On Active Attention." *Mind*, n. s. 11 (1902), pp. 1–30.
- Braid, James. *Neurypnology or the Rationale of Nervous Sleep*. London: J. Churchill, 1843.
- Breuer, Josef, and Sigmund Freud. *Studies in Hysteria*. Trans. James Strachey. New York: Basic Books, 1957.
- Brown-Sequard, Charles-Edouard. "Dynamogenie." In *Dictionnaire encyclopedique des sciences medicales*, 1st series, vol. 30, pp. 756–760. Paris: Asselin, 1885.
- Brown-Sequard, Charles-Edouard. *Physiology and Pathology of the Central Nervous System*. Philadelphia: Lippincott, 1858.
- Brown-Sequard, Charles-Edouard. *Recherches experimentales et cliniques sur l'inhibition et la dynamogenie*. Paris: Masson, 1882.
- Cappie, James. "Some Points in the Physiology of Attention, Belief and Will." *Brain* 9 (July 1886), pp. 196–206.
- Carpenter, William B. *Principles of Human Physiology*. Philadelphia: Blanchard and Lea, 1853.
- Carpenter, William B. *Principles of Mental Physiology* (1874). 4th ed. London: Kegan Paul, 1896.
- Cassirer, Ernst. *Das Erkenntnisproblem in der Philosophie und der Wissenschaft der neueren Zeit*. Vol. 3 (1907). Darmstadt: Wissenschaftliche Buchgesellschaft, 1971.
- Cattell, James McKeen. "Address of the President before the American Psychological Association." *Psychological Review* 3 (1896), pp. 134–148.
- Cattell, James McKeen. "The Conceptions and Methods of Psychology." *Popular Science Monthly* 66 (1904), pp. 176–186.
- Cattell, James McKeen. "Experiments on the Association of Ideas." *Mind* 12 (1887), pp. 68–74.
- Cattell, James McKeen. "The Inertia of Eye and Brain." *Brain* 8 (October 1885), pp. 295–312.
- Cattell, James McKeen. "Mental Tests and Their Measurement." *Mind* 15 (1890), pp. 373–380.
- Cézanne, Paul. *Letters*. Ed. John Rewald. Trans. Marguerite Kay. Oxford: Cassirer, 1946.
- Cezanne, Paul, et al. *Conversations avec Cezanne*. Ed. P. M. Doran. Paris: Macula, 1978.
- Chaignet, Anthelme Edouard. *Pythagore et la philosophie pythagoricienne*. 2 vols. Paris: Didier, 1873.
- Charcot, J.-M. *Clinical Lectures on Diseases of the Nervous System*. Ed. Ruth Harris. London: Tavistock, 1991.
- Charcot, J.-M., and Paul Richer. *Les demoniaques dans l'art*. Paris: Delhaye et Lecrosnier, 1887.
- Cocke, James R. *Hypnotism: How It Is Done, Its Uses and Dangers*. Boston: Arena, 1894.
- Condillac, Etienne Bonnot de. "Essay on the Origin of Human Knowledge." In *Philosophical Writings of Etienne Bonnot, Abbe de Condillac*, vol. 2, trans. Franklin Philip. Hillsdale, N.J.: Lawrence Erlbaum, 1987.
- Cousin, Victor. *Elements of Psychology*. Trans. Caleb Henry. New York: Ivison & Phinney, 1856.
- Croce, Benedetto. *Aesthetic* (1901). Trans. Douglas Ainslie. London: Peter Owen, 1953.
- Darwin, Charles. *The Descent of Man, and Selection in Relation to Sex* (1871). Princeton: Princeton University Press, 1981.
- Delboeuf, Joseph. *Le sommeil et les rêves*. Paris: Félix Alcan, 1885.
- Dewey, John. *Psychology*. New York: Harper, 1886.
- Dewey, John. "The Reflex Arc Concept." *Psychological Review* 3, no. 4 (July 1896), pp. 357–370.
- Dilthey, Wilhelm. *Introduction to the Human Sciences* (1883). Ed. Rudolf A. Makkreel and Frithjof Rodi. Princeton: Princeton University Press, 1989.
- Dilthey, Wilhelm. *Selected Works*. Vol. 5: *Poetry and Experience*. Ed. Rudolf A. Makkreel and Frithjof Rodi. Princeton: Princeton University Press, 1985.
- Dodds, W. J. "On Some Central Affections of Vision." *Brain* 8 (1886), pp. 21–39.
- Dolley, Charles S., and James McKeen Cattell. "On Reaction Times and the Velocity of the Nervous Impulse." *Psychological Review* 1, no. 2 (1894), pp. 159–168.
- Du Maurier, Georges. *Trilby*. New York: Harper and Brothers, 1894.
- Durkheim, Emile. *The Division of Labor in Society* (1893). Trans. W. D. Halls. New York: Free Press, 1984.

- Durkheim, Emile. *The Rules of Sociological Method* (1895). Trans. Sarah Solovay and John Mueller. New York: Free Press, 1964.
- Durkheim, Emile. *Sociology and Philosophy*. Trans. D. F. Pocock. Glencoe, Ill.: Free Press, 1953.
- Ebbinghaus, Hermann. *Grundzüge der Psychologie*. 2 vols. Leipzig: Veit, 1905.
- Ebbinghaus, Hermann. *Memory: A Contribution to Experimental Psychology* (1885). Trans. Henry Ruger and Clara Bussenius. New York: Dover, 1964.
- Ehrenfels, Christian von. "Über Gestaltqualitäten." *Vierteljahrsschrift für wissenschaftliche Philosophie* 14 (1890), pp. 249–292. English trans. as "On Gestalt Qualities," in Barry Smith, ed., *Foundations of Gestalt Theory*. Munich: Philosophia Verlag, 1982.
- Engels, Friedrich. *Dialectics of Nature*. Trans. Clemens Dutt. New York: International Publishers, 1940.
- Fechner, Gustav. *Elemente der Psychophysik*. 2 vols. Leipzig: Breitkopf und Hartel, 1860. English trans. as *Elements of Psychophysics*, trans. Helmut Adler. New York: Holt, Rinehart, 1966.
- Fechner, Gustav. *Vorschule der Aesthetik*. 2 vols. Leipzig: Breitkopf und Hartel, 1876.
- Fere, Charles. "Degenerescence et criminalité." *Revue philosophique* 24 (October 1887), pp. 337–377.
- Fere, Charles. "L'énergie et la vitesse des mouvements volontaires." *Revue philosophique* 28 (July–December 1889), pp. 37–68.
- Fere, Charles. *La pathologie des émotions*. Paris: Felix Alcan, 1892.
- Fere, Charles. *Sensation et mouvement* (1887). Paris: F. Alcan, 1900.
- Ferrier, David. *The Functions of the Brain*. London: Smith Elder, 1876.
- Fiedler, Konrad. *On Judging Visual Works of Art* (1876). Trans. Henry Shaefer-Simmern. Berkeley: University of California Press, 1949.
- Fouillée, Alfred. *Nietzsche et l'immoralisme*. Paris: F. Alcan, 1902.
- Fouillée, Alfred. "Le physique et le mental: A propos de l'hypnotisme." *Revue des Deux Mondes* 105 (May 1, 1891), pp. 429–461.
- Fouillée, Alfred. "La sensation et la pensée selon le sensualisme et le platonisme contemporains." *Revue des Deux Mondes* 82 (July 15, 1887), pp. 398–425.
- Freud, Sigmund. *The Interpretation of Dreams*. Trans. James Strachey. New York: Avon, 1965.
- Freud, Sigmund. *The Letters of Sigmund Freud*. Trans. Tania and James Stern. New York: Basic Books, 1975.
- Freud, Sigmund. "Project for a Scientific Psychology." In *The Origins of Psycho-analysis*, trans. Eric Mosbacher and James Strachey, pp. 415–445. New York: Basic Books, 1954.
- Galton, Francis. *Inquiries into Human Faculty and Its Development*. London: Macmillan, 1883.
- Gasquet, Joachim. *Joachim Gasquet's Cezanne: A Memoir with Conversations*. Trans. Christopher Pemberton. London: Thames and Hudson, 1991.
- Geymuller, H. de. "Derniers travaux sur Leonard de Vinci." *Gazette des Beaux-Arts* 34 (1886), pp. 143–164.
- Gilles de la Tourette, Georges. *L'hypnotisme et les états analogues au point de vue médico-légal*. Paris: E. Plon, 1887.
- Gley, E. "C.-E. Brown-Sequard." *Archives de physiologie normale et pathologique*, 5th ser., 6 (1894), pp. 759–770.
- Guyau, Jean-Marie. *L'art au point de vue sociologique*. Paris: F. Alcan, 1889.
- Hall, G. Stanley. "Reaction-Time and Attention in the Hypnotic State." *Mind* 8 (1883), pp. 171–182.
- Hartmann, Eduard von. *Philosophy of the Unconscious* (1868). Trans. William C. Coupland. London: Routledge, 1931.
- Hegel, G. W. F. *Hegel's Philosophy of Mind*. Trans. William Wallace and A. V. Miller. Oxford: Oxford University Press, 1971.
- Hegel, G. W. F. *The Phenomenology of Mind*. Trans. J. B. Baillie. New York: Harper and Row, 1967.

- Helmholtz, Hermann von. *Treatise on Physiological Optics*. 2 vols. Ed. James P. C. Southall. New York: Dover, 1962. French trans. as *Optique physiologique*, trans. Emile Javal and N. Th. Klein. Paris: Victor Masson, 1867.
- Helmholtz, Hermann von. *Science and Culture: Popular and Philosophical Essays*. Trans. David Cahan. Chicago: University of Chicago Press, 1995.
- Henry, Charles. *Cercle chromatique, présentant tous les complements et toutes les harmonies de couleurs*. . . . Paris: C. Verdin, 1888.
- Henry, Charles. "Le contraste, le rythme, la mesure." *Revue philosophique* 28 (July-December 1889), pp. 356–381.
- Henry, Charles. "Introduction a une esthetique scientifique." *Revue contemporaine* (1885).
- Henry, Charles. "Sur l'origine de quelques notations mathematiques." *Revue archeologique* 37 (1878), pp. 324–333; 38 (1879), pp. 1–10.
- Hering, Ewald. *Outlines of a Theory of the Light Sense*. Trans. Leo M. Hurvich and Dorothea Jameson. Cambridge: Harvard University Press, 1964.
- Hibben, John Grier. "Sensory Stimulation by Attention." *Psychological Review* 2, no. 4 (July 1895), pp. 369–375.
- Hildebrand, Adolf. "The Problem of Form in the Fine Arts" (1893). In Harry Mallgrave and Eleftherios Ikonomou, eds., *Empathy, Form, and Space: Problems in German Aesthetics 1873–1893*, pp. 227–280. Santa Monica: Getty Center for the History of Art and the Humanities, 1994.
- Hoch, August. "A Review of Some Recent Papers upon the Loss of the Feeling of Reality and Kindred Symptoms." *Psychological Bulletin* 2, no. 7 (July 15, 1905), pp. 233–241.
- Hoffmansthal, Hugo von. *Selected Prose*. Trans. Mary Hottinger et al. New York: Pantheon, 1952.
- Humbert de Superville, D. P. G. "Essay on the Unconditional Signs in Art" (1827). In *Miscellanea Humbert de Superville*, ed. Jacob Bolten. Leiden, 1997.
- Husserl, Edmund. *Logical Investigations* (1899–1901). Trans. J. N. Findlay. 2 vols. New York: Humanities Press, 1970.
- Husserl, Edmund. *The Phenomenology of Internal Time Consciousness* (1905–1910). Trans. James S. Churchill. Bloomington: Indiana University Press, 1964.
- Huxley, Thomas H. *Collected Essays*. Vol. 1. New York: D. Appleton, 1917.
- Huysmans, Joris-Karl. *L'art moderne/ Certains*. Paris: Union Generale d'Editions, 1975.
- Hyslop, Theodor B. *Mental Psychology Especially in Its Relations to Mental Disorders*. London: Churchill, 1895.
- Iamblichus. *On the Pythagorean Life*. Trans. Gillian Clark. Liverpool: Liverpool University Press, 1989.
- Jackson, John Hughlings. *Selected Writings of John Hughlings Jackson*. 2 vols. Ed. James Taylor. London: Hodder and Stoughton, 1932.
- James, William. *The Principles of Psychology* (1890). 2 vols. New York: Dover, 1950.
- Janet, Pierre. "Attention." In Charles Richet, ed., *Dictionnaire de physiologie*, vol. 1, pp. 831–839. Paris: Felix Alcan, 1895.
- Janet, Pierre. *L'automatisme psychologique*. Paris: Felix Alcan, 1889.
- Janet, Pierre. "Etude sur un cas d'aboulie et d'idees fixes." *Revue philosophique* 31 (1891), pp. 258–287, 382–407.
- Janet, Pierre. *The Mental State of Hystericals* (1893). Trans. Caroline Corson. New York: Putnam, 1902.
- Janet, Pierre. *Neuroses et idees fixes*. Paris: Felix Alcan, 1898.
- Jevons, W. Stanley. "The Power of Numerical Discrimination." *Nature*, February 9, 1871, pp. 281–282.
- Jullien, Adolphe. "'Les Maitres Chanteurs de Nuremberg' de Richard Wagner." *L'Art* 45 (1888), pp. 153–160.

- Jullien, Adolphe. *Richard Wagner: Sa vie et ses oeuvres*. Paris: J. Rouam, 1886.
- Kahn, Gustave. "Peinture: Exposition des Independantes." *Revue independante* 6 (April 1888), pp. 160–164.
- Kahn, Gustave. "Seurat." *L'art moderne* 11 (April 5, 1891), pp. 107–110.
- Kant, Immanuel. *Critique of Pure Reason*. Trans. Norman Kemp Smith. New York: St. Martin's, 1965.
- Kant, Immanuel. *Prolegomena to Any Future Metaphysics*. Ed. Lewis White Beck. Indianapolis: Bobbs-Merrill, 1950.
- Krafft-Ebing, Richard von. *Psychopathia Sexualis* (1886). Trans. Harry E. Wedeck. New York: Putnam, 1965.
- Kreibitz, Josef Clemens. *Die Aufmerksamkeit als Willenserscheinung*. Vienna: Alfred Holder, 1897.
- Kulpe, Oswald. *Outlines of Psychology* (1893). Trans. E. B. Titchener. London: Sonnenschein, 1895.
- Kulpe, Oswald. "The Problem of Attention." *Monist* 13, no. 1 (October 1902), pp. 38–68.
- Ladd, George Trumbull. *Elements of Physiological Psychology*. New York: Scribner, 1887.
- Lafontaine, Charles. *Memoires d'un magnetiseur*. Paris: Balliere, 1866.
- Lalande, Andre. "Sur un effet particulier de l'attention appliquee aux images." *Revue philosophique* 35 (March 1893), pp. 284–287.
- Laycock, Thomas. "Reflex, Automatic and Unconscious Cerebration: A History and a Criticism." *Journal of Mental Science* 21, no. 96 (January 1876), pp. 477–498.
- Le Bon, Gustave. *The Crowd* (1895). New York: Viking, 1960.
- Le Roux, Hugues. *Les jeux du cirque et la vie foraine*. Paris: Pion, 1889.
- Liebeault, Auguste. *Du sommeil et des etats analogues consideres au point de vue de l'action du moral sur le physique*. Paris: V. Masson, 1866.
- Liebeault, Auguste. *Le sommeil provoque et les etats analogues*. Paris: Doin, 1889.
- Liegeois, Jules. *De la suggestion et du somnambulisme dans leurs rapports avec la jurisprudence et la medecine legale*. Paris: Doin, 1889.
- Lipps, Theodor. *Grundriss der Seelenlehre*. Bonn: M. Cohen, 1883.
- Lipps, Theodor. *Psychological Studies* (1885). Trans. Herbert C. Sanborn. Baltimore: Williams and Wilkins, 1926.
- Lissauer, Hermann. "Ein Fall von Seelenblindheit nebst einem Beitrage zur Theorie derselben." *Archiv fur Psychiatrie und Nervenkrankheiten* 21 (1890), pp. 222–270.
- Locke, John. *An Essay Concerning Human Understanding* (1690). 2 vols. New York: Dover, 1959.
- Loewy, Emanuel. *The Rendering of Nature in Early Greek Art*. Trans. John Fothergill. London: Duckworth, 1907.
- Lombroso, Cesare. *L'homme criminel: Etude anthropologique et medico-legale* (1876). Trans. G. Regnier and A. Bournet. Paris: F. Alcan, 1887.
- Luckey, George W. "Comparative Observations on the Indirect Color Range of Children, Adults, and Adults Trained in Color." *American Journal of Psychology* 6, no. 4 (January 1895), pp. 489–504.
- Mach, Ernst. *Contributions to the Analysis of the Sensations* (1885). Trans. C. M. Williams. La Salle, Ill.: Open Court, 1890.
- Mach, Ernst. *Popular Scientific Lectures*. Trans. Thomas J. McCormack. La Salle, Ill.: Open Court, 1893.
- Maine de Biran, Pierre. *De l'apperception immediate* (1807). Paris: J. Vrin, 1963.
- Malebranche, Nicolas. *The Search after Truth* (1675). Trans. Thomas M. Lennon and Paul J. Olscamp. Cambridge: Cambridge University Press, 1997.
- Mallarme, Stephane. *Correspondance*. Vol. 2. Ed. Henri Mondor and Lloyd James Austin. Paris: Gallimard, 1965.

- Mallarmé, Stéphane. *La Dernière Mode: Gazette du monde et de la famille*. Paris: Ramsay, 1978.
- Mallarmé, Stéphane. "The Impressionists and Edouard Manet" (1876). In Penny Florence, *Mallarmé, Manet, and Redon*, pp. 11–18. Cambridge: Cambridge University Press, 1986.
- Mallarmé, Stéphane. *Oeuvres complètes*. Paris: Gallimard, 1945.
- Mallarmé, Stéphane. *Selected Letters of Stéphane Mallarmé*. Trans. Rosemary Lloyd. Chicago: University of Chicago Press, 1988.
- Marillier, Leon. "Remarques sur le mecanisme de l'attention." *Revue philosophique* 27 (1889), pp. 566–587.
- Marx, Karl. *Capital*. 3 vols. Trans. Samuel Moore and Edward Aveling. New York: International Publishers, 1967.
- Marx, Karl. *Grundrisse*. Trans. Martin Nicolaus. New York: Random House, 1973.
- Maudsley, Henry. *Body and Will*. New York: D. Appleton, 1884.
- Maudsley, Henry. *The Physiology and Pathology of Mind*. 2d ed. London: Macmillan, 1868.
- Maudsley, Henry. *The Physiology of Mind*. New York: D. Appleton, 1883.
- Maupassant, Guy de. *The Horla and Other Stories*. Trans. S. Jameson. New York: Knopf, 1925.
- Maurly, L.-F. Alfred. *Le sommeil et les rêves*. Paris: Didier, 1878.
- Menard, L. "L'inhibition." *Cosmos: Revue des sciences* 71 (June 4, 1887), pp. 255–256.
- Meyerson, Emile. *Identity and Reality* (1908). Trans. Kate Loewenberg. New York: Dover, 1962.
- Mintorn, William. *La somnambule*. Paris: Ghio, 1880.
- Moll, Albert. *Hypnotism* (1889). New York: Scribner, 1899.
- Morand, J.-S. *Le magnétisme animal: Etude historique et critique*. Paris: Garnier, 1889.
- Mosso, Angelo. *Fatigue* (1891). Trans. Margaret Drummond. New York: G. P. Putnam, 1904.
- Muller, Georg Elias. *Zur Theorie der sinnlichen Aufmerksamkeit*. Leipzig: A. Edelmann, 1873.
- Münsterberg, Hugo. *Psychology and the Teacher*. New York: D. Appleton, 1909.
- Muntz, Eugene. "Les expositions de Londres." *Gazette des Beaux-Arts* 6 (September 1872), pp. 236–249; (October 1872), pp. 312–325.
- Nayrac, Jean-Paul. *Physiologie et psychologie de l'attention*. Paris: F. Alcan, 1906.
- Nietzsche, Friedrich. *Beyond Good and Evil* (1886). Trans. Walter Kaufmann. New York: Random House, 1966.
- Nietzsche, Friedrich. *The Case of Wagner* (1888). Trans. Walter Kaufmann. New York: Random House, 1967.
- Nietzsche, Friedrich. *Philosophy and Truth*. Trans. Daniel Breazeale. Atlantic Highlands, N.J.: Humanities Press, 1979.
- Nietzsche, Friedrich. *Selected Letters of Friedrich Nietzsche*. Ed. Christopher Middleton. Chicago: University of Chicago Press, 1969.
- Nietzsche, Friedrich. *Untimely Meditations*. Trans. R. J. Hollingdale. Cambridge: Cambridge University Press, 1983.
- Nietzsche, Friedrich. *The Will to Power* (1888). Trans. Walter Kaufmann. New York: Random House, 1967.
- Nordau, Max. *Degeneration* (1892). New York: Appleton, 1895.
- Obersteiner, Heinrich. "Experimental Researches on Attention." *Brain* 1 (1879), pp. 439–453.
- Packard, Frederic H. "The Feeling of Unreality." *Journal of Abnormal Psychology* 1 (1906), pp. 69–82.
- Parinaud, Henri. "Paralysis of the Movement of Convergence of the Eyes." *Brain* 25 (October 1886), pp. 330–341.
- Pater, Walter. *The Renaissance: Studies in Art and Poetry* (1873). Berkeley: University of California Press, 1980.
- Peirce, Charles Sanders. *Collected Papers of Charles Sanders Peirce*. Vol. 8. Ed. Arthur W. Burks. Cambridge: Harvard University Press, 1958.
- Peirce, Charles Sanders. *Charles S. Peirce: Selected Writings*. Ed. Philip P. Wiener. New York: Dover, 1958.

- Peirce, Charles Sanders. *Writings of Charles S. Peirce*. Ed. Max H. Fisch. Vol. 2. Bloomington: Indiana University Press, 1982.
- Pillsbury, Walter B. *Attention* (1906). London: Sonnenschein, 1908.
- Pilzecker, Alfons. *Die Lehre von sinnliche Aufmerksamkeit*. Munich: Akademische Buchdruckerei von F. Straub, 1889.
- Poe, Edgar Allan. *Poetry and Tales*. New York: Library of America, 1984.
- Poincaré, Henri. *Science and Hypothesis* (1902). Trans. J. Larmor. New York: Dover, 1952.
- Ravaisson-Mollien, Charles. "Les écrits de Leonard de Vinci." *Gazette des Beaux-Arts* 23 (1881), pp. 225ff, 331ff, 514ff.
- Renouvier, Charles. *Essais de critique generale: Premier essai*. Paris: Ladrangé, 1854.
- Ribot, Théodule. *The Diseases of the Will*. Trans. Merwin-Marie Snell. Chicago: Open Court, 1894.
- Ribot, Théodule. *La psychologie de l'attention*. Paris: F. Alcan, 1889. English trans. as *The Psychology of Attention*. Chicago: Open Court, 1896.
- Richet, Charles. "Du somnambulisme provoqué." *Journal de l'anatomie et de la physiologie normales et pathologiques* 11 (1875), pp. 348–378.
- Richet, Charles (pseud. Charles Epheyre). "Soeur Marthe." *Revue des Deux Mondes* 93 (May 15, 1889), pp. 384–431.
- Riegl, Alois. "The Dutch Group Portrait" (excerpts). *October* 74 (Fall 1995), pp. 3–35.
- Rilke, Rainer Maria. *Letters of Rainer Maria Rilke 1892–1910*. Trans. Jane B. Green and M. D. Norton. New York: Norton, 1945.
- Rilke, Rainer Maria. *Letters on Cezanne*. Trans. Joel Agee. New York: Fromm, 1985.
- Rimbaud, Arthur. *Oeuvres complètes*. Paris: Gallimard, 1972.
- Rousseau, Jean-Jacques. *Reveries of a Solitary Walker* (1776). Trans. Peter France. London: Penguin, 1979.
- Ruskin, John. *The Elements of Drawing* (1857). New York: Dover, 1971.
- Ruskin, John. *The Seven Lamps of Architecture* (1848). New York: Noonday, 1977.
- Ruskin, John. *The Stones of Venice*. Ed. J. G. Links. New York: Hill and Wang, 1964.
- Sanctis, Sante de. *L'attenzione e i suoi disturbi*. Rome. Tip. dell'Unione Coop. Edit., 1896.
- Schelling, F. W. J. *The Ages of the World*. Trans. Frederick deWolfe Bolman. New York: Columbia University Press, 1942.
- Schopenhauer, Arthur. *Parerga and Paralipomena: Short Philosophical Essays* (1851). Vol. 2. Trans. E. F. J. Payne. Oxford: Oxford University Press, 1974.
- Schopenhauer, Arthur. *The World as Will and Representation*. 2 vols. Trans. E. F. J. Payne. New York: Dover, 1966.
- Scott, Walter D. *The Psychology of Advertising*. Boston: Small, Maynard & Co., 1908.
- Seailles, Gabriel. *Leonard de Vinci: L'artiste et savant. Essai de biographie psychologique*. Paris: Perrin, 1892.
- Seailles, Gabriel. "Peintres contemporains: Puvis de Chavannes." *Revue bleue: Revue politique et littéraire* 6 (February 11, 1888), pp. 179–185.
- Sechenov, Ivan. *Reflexes of the Brain* (1863). Trans. S. Belsky. Cambridge: MIT Press, 1965.
- Sergi, Giuseppe. *La psychologie physiologique* (1885). Paris: F. Alcan, 1888.
- Seurat, Georges, et al. *Seurat: Correspondances, témoignages, notes inédites, critiques*. Ed. Hélène Seyres. Paris: Acropole, 1991.
- Sherrington, Charles S. *The Integrative Action of the Nervous System*. New York: Scribner, 1906.
- Signac, Paul. *D'Eugène Delacroix au neo-impressionisme* (1899). Paris: Hermann, 1978.
- Simmel, Georg. *On Individuality and Social Forms*. Ed. Donald N. Levine. Chicago: University of Chicago Press, 1971.
- Simmel, Georg. *On Women, Sexuality and Love*. Trans. Guy Oakes. New Haven: Yale University Press, 1984.
- Simmel, Georg. *The Philosophy of Money* (1900). Trans. Tom Bottomore and David Frisby. London: Routledge, 1978.

- Slaughter, J. W. "The Fluctuations of Attention in Some of Their Psychological Relations." *American Journal of Psychology* 12, no. 3 (1901), pp. 314–334.
- Soubies, Albert, and Charles Malherbes. *L'oeuvre dramatique de Richard Wagner*. Paris: Fischbacher, 1886.
- Souriau, Paul. *La suggestion dans l'art*. Paris: Felix Alcan, 1893.
- Spencer, Herbert. *The Principles of Psychology*. 3d ed. 2 vols. New York: D. Appleton, 1871–1872.
- Stanley, Hiram M. "Attention as Intensifying Sensation." *Psychological Review* 2, no. 1 (1895), pp. 53–57.
- Stein, Gertrude. "Cultivated Motor Automatism: A Study of Character in Its Relation to Attention." *Psychological Review* 5, no. 3 (May 1898), pp. 295–306.
- Stoker, Bram. *Dracula* (1897). Oxford: Oxford University Press, 1983.
- Stout, George Frederick. *Analytic Psychology*. 2 vols. London: Sonnenschein, 1896.
- Strindberg, August. *Three Plays*. Trans. Peter Watts. Harmondsworth: Penguin, 1958.
- Stumpf, Carl. "Hermann von Helmholtz and the New Psychology." *Psychological Review* 2, no. 1 (January 1895), pp. 1–12.
- Stumpf, Carl. *Tonspsychologie*. 2 vols. Leipzig: S. Hirzel, 1890.
- Sully, James. "The Psycho-Physical Processes in Attention." *Brain* 13 (1890), pp. 145–164.
- Sutter, David. *Nouvelle theorie simplifiee de la perspective*. Paris: Jules Tardieu, 1859.
- Sutter, David. "Les phenomenes de la vision." *L'Art* 20 (1880), pp. 74ff.
- Taine, Hippolyte. *Derniers essais de critique et d'histoire*. Paris: Hachette, 1894.
- Taine, Hippolyte. *On Intelligence* (1869). Trans. T. D. Haye. New York: Henry Holt, 1875.
- Tarde, Gabriel. "Categories logiques et institutions sociales." *Revue philosophique* 28 (August 1889), pp. 113–136.
- Tarde, Gabriel. *The Laws of Imitation* (1890). Trans. E. C. Parsons. New York: Henry Holt, 1903.
- Tarde, Gabriel. *On Communication and Social Influence: Selected Papers of Gabriel Tarde*. Ed. Terry N. Clark. Chicago: University of Chicago Press, 1969.
- Titchener, Edward B. *Experimental Psychology: A Manual of Laboratory Practice*. Vol. 1. New York: Macmillan, 1901.
- Titchener, Edward B. *Lectures on the Elementary Psychology of Feeling and Attention*. New York: Macmillan, 1908.
- Tonnies, Ferdinand. *Community and Society* (1887). Trans. Charles P. Loomis. East Lansing: Michigan State University Press, 1957.
- Uhl, Lemon. *Attention*. Baltimore: Johns Hopkins University, 1890.
- Valery, Paul. *The Collected Works of Paul Valery*. Vol. 8: *Leonardo, Poe, Mallarmé*. Trans. Malcolm Cowley and James R. Lawler. Princeton: Princeton University Press, 1972.
- Valery, Paul. *The Collected Works of Paul Valery*. Vol. 12: *Degas, Manet, Morisot*. Trans. David Paul. Princeton: Princeton University Press, 1960.
- Verhaeren, Emile. "Georges Seurat." *La Societe nouvelle*, April 1891, pp. 420–438.
- Veron, Eugene. *L'esthetique*. Paris: C. Reinwald, 1878.
- Wagner, Cosima. *Cosima Wagner's Diaries*. 2 vols. Trans. Geoffrey Skelton. New York: Harcourt Brace, 1977.
- Wagner, Richard. *Judaism in Music and Other Essays*. Trans. W. Ashton Ellis. Lincoln: University of Nebraska Press, 1995.
- Wagner, Richard. *Opera and Drama*. Trans. W. Ashton Ellis. Lincoln: University of Nebraska Press, 1995.
- Wagner, Richard. *Religion and Art*. Trans. W. Ashton Ellis. Lincoln: University of Nebraska Press, 1994.
- Weber, Max. *The Protestant Ethic and the Spirit of Capitalism* (1904). Trans. Talcott Parsons. New York: Scribner, 1958.
- Wells, H. G. *Three Prophetic Novels*. Ed. E. F. Bleiler. New York: Dover, 1960.
- Wernicke, Carl. *Der aphasische Symptomencomplex*. Breslau: Cohn and Weigert, 1874. English

- trans. as "The Symptom Complex of Aphasia." In R. Cohen, ed., *Boston Studies in the Philosophy of Science*, vol. 4, pp. 34–97. New York: Humanities Press, 1969.
- Wundt, Wilhelm. *Grundzuge der physiologischen Psychologie* (1874). 2 vols. Leipzig: Engelmann, 1880. English trans. as *Principles of Physiological Psychology*, trans. Edward Bradford Titchener. New York: Macmillan, 1904.
- Wundt, Wilhelm. *Outlines of Psychology* (1893). 4th rev. ed. Trans. Charles H. Judd. Leipzig: Engelmann, 1902.
- Wyzewa, Teodor de. "Le pessimisme de Richard Wagner." *Revue wagnérienne* 6 (July 8, 1885), pp. 167–170.
- Ziehen, Theodor. *Introduction to Physiological Psychology*. Trans. C. C. van Liew. London: Sonnenschein, 1892.

- Adams, Henry, 65n159
 Adorno, Theodor, 48–49, 117n77, 119n79,
 226n180, 247n240, 251, 261, 280, 343
 Adultery, 106–108
 Advertising, 72n179
 Aesthetics, 46, 48–49, 51, 95, 151–152, 154,
 158, 163, 170, 173, 223, 316
 Agamben, Giorgio, 110
 Agnosia, 94–95
 Agoraphobia, 366
 Albert Hall (London), 121–122
 Alberti, Leon Battista, 220
 Alexander, Christopher, 183n79
 Allen, Grant, 170n42
 Allport, Alan, 33n59
 Amnesia. *See* Forgetting
 Anarchism, 206
 Androgyny, 207–209, 212
 Anesthesia, 38–39, 111, 164, 206
 Angell, James R., 63n151
 Anomie, 84, 179, 182–185, 206
 Anti-Cartesianism, 44n90, 114
 Aphasia, 94–95
 Apperception, 15, 19, 38, 56, 291–292, 314,
 324
 Apter, Emily, 115n74
 Architecture, 50, 122, 225, 365–366
 Arendt, Hannah, 53–54
 Areñs, Katherine, 25n35, 335n120
 Arguelles, Jose, 164n28, 165n33, 177n63
 Aristotle, 205n128
 Armstrong, Carol, 109n62
 Aron, Raymond, 184n80
 Arrighi, Giovanni, 32n56
 Art, archaic, 228–229
 Art, modernist, 5–6, 12, 45, 94, 97, 159, 213,
 357
 Art nouveau, 172
 Asendorf, Christoph, 84n4
 Ash, Mitchell G., 156n10
 Ashberry, John, 129n101
 Associationism, 20, 27, 42–43, 56, 59,
 61n143, 155, 180, 284, 304
 inadequacy of, 20–21
 Atomism, 157, 180
 Attali, Jacques, 204
 Attention, 1–5, 9–10, 13–14, 127, 137, 150,
 239–241
 anti-optical models of, 4, 113, 244–245,
 289
 Bergson on, 317, 322–327
 and commodity culture, 115, 117, 119,
 309
 disciplinary, 37, 63, 77, 137, 278
 as experience, 281, 305, 361–362
 as fixation, 19, 37, 45, 61, 63–65, 67, 126,
 133, 150, 160, 283, 297, 299
 Freud on, 96, 105, 129, 335, 367–368
 Husserl on, 283–286
 and hypnosis, 65–71, 239–240
 and indexical signs, 114–115
 and inhibition, 38–41, 62
 James on, 61–63
 limits of, 24, 29, 47–48, 65, 73–75, 77, 97,
 289, 297
 management of, 4, 13–14, 25, 33, 37, 43,
 49, 72–73, 137, 176, 201, 253, 255,
 278, 358

- Attention (*cont.*)
 and modern nihilism, 126
 normative models of, 4, 23, 29, 47, 64,
 92, 96–97, 105–106, 110, 118
 pathological, 47, 64, 96–97, 133, 325–326
 Peirce on, 59–60, 114–115
 premodern theories of, 17–21, 52
 and reflex arc, 312
 and schizophrenia, 37–38, 326
 as selection, 1, 17, 24, 37–38, 62, 106,
 133–134, 147, 362
 Sherrington on, 350
 and subjectivity, 44–45, 63–65, 126
 Wagner and, 248–252
 and will, 25, 42–43, 47, 325
- Attention deficit disorder, 35–37, 43
- Augustine, Saint, 17
- Aura, 122, 224–227, 328
- Automatic behavior, 40–41, 53, 68, 70, 78,
 99, 102, 138, 229–230, 239, 314, 326,
 318n82, 336
 and depersonalization, 340–341
 and perception, 79, 97, 147–148, 318
 and regression, 147–148
- Automobile, 78n193, 309
- Autonomy, 25, 46, 84, 152, 154, 157, 229,
 317, 344
- Auzel, Dominique, 259n268
- Avenarius, Richard, 155n9, 163
- Bachelard, Gaston, 102
- Badt, Kurt, 341
- Baer, Ulrich, 306n51
- Bain, Alexander, 20, 284n11
- Baldwin, James Mark, 171
- Bann, Stephen, 343n137
- Barroys, Susanna, 246n234
- Barthelemy-Madaule, Madeleine, 324n100
- Barthes, Roland, 9n4, 146, 209n141
- Barzun, Jacques, 252n253
- Bastian, Charlton, 20n22, 22n27
- Bataille, Georges, 4, 52n117, 88, 204
- Baudelaire, Charles, 84, 99n35
- Baudrillard, Jean, 211n143
- Baxandall, Michael, 19n18
- Bayreuth, 148, 249–255, 258, 278
- Beaubourg, Maurice, 205
- Beaune, Jean-Claude, 147n126, 230n187
- Behaviorism, 33, 157–158, 307
- Bell, Clive, 159n17
- Bellamy, Elizabeth J., 362n2
- Bellour, Raymond, 238n204
- Belting, Hans, 229n183
- Benjamin, Walter, 1, 4, 48–51, 99, 225n174,
 318, 327, 358
- Berger, Peter L., 318n82
- Bergson, Henri, 15, 27, 41n86, 42, 54, 56,
 155n8, 158, 166n35, 239–240, 311,
 316–328, 335–337, 351, 354, 357
Matter and Memory, 316–326
Time and Free Will, 158, 166n35, 239
- Berkeley, George, 18
- Bernheim, Hippolyte, 66–67, 69–70, 235,
 239
- Bersani, Leo, 119
- Binary systems, 110, 150, 174–175, 207,
 209–212, 227
- Binding, 9, 15–16, 92, 105–109, 115, 126,
 128, 332, 352
 Freud and, 107
- Binet, Alfred, 23, 39, 115, 155n9, 230n188
- Biology, 36, 41, 310, 319, 335n120
- Blake, William, 357
- Blanc, Charles, 163, 192n97
- Blanchot, Maurice, 4
- Bleuler, Eugen, 38
- Blind spot, 40
- Bloch, Ernst, 179, 223, 226, 355n169,
 357n172
- Body, 12–13, 20, 54, 93, 108, 111–112, 224
 management of, 23, 93, 172, 287
 mechanization of, 147, 307
 of observer, 3, 153–154, 215
 as surface, 218–220
 temporality of, 56, 353
- Bois, Yve-Alain, 340n128
- Bolton, Thaddeus, 64n157
- Bonitzer, Pascal, 100n39
- Bonnard, Pierre, 297n30
- Bonnier, Charles and Pierre, 253–254
- Borch-Jacobsen, Mikkel, 241
- Boredom, 78
- Boring, Edwin G., 290n20, 307n55
- Bossi, Giuseppe, 191n95

- Botstein, Leon, 221n167
 Bourdieu, Pierre, 104n48
 Bradley, F. H., 22n27, 38n78
 Braid, James, 66, 235, 239
 Brain, 36, 38, 41, 60, 243, 341, 358
 Brantlinger, Patrick, 246n234
 Braun, Marta, 166n34
 Brenkman, John, 223n172
 Breuer, Josef, 96, 104
 Brion-Guerry, Liliane, 347
 Broadbent, Donald, 33n59
 Brodsky, Joseph, 78n194
 Bronzino, Agnolo, 111
 Brooks, John L., 61n143
 Broude, Norma, 226n177
 Brown, Norman O., 223
 Brown, Peter, 101n40
 Brown-Sequard, Charles-Edouard, 164–165,
 171, 172n49, 239
 Bruckner, Anton, 156
 Bruner, Jerome, 23n29
 Buchloh, Benjamin, 279n285
 Buci-Glucksmann, Christine, 108
 Burch, Noel, 138, 345n145
 Burgin, Victor, 30n50, 209
 Burns, E. Bradford, 145n120
 Butler, Judith, 207n135, 210n142

 Cachin, Françoise, 201n117
 Caillebotte, Gustave, 131n105
 Camera obscura model of vision, 24, 39,
 292, 315
 Camus, Albert, 286n14
 Canguilhem, Georges, 230n187, 318n83,
 348
 Capek, Milic, 323n94
 Capitalism, 33, 75, 84, 92, 140, 144–145,
 157, 181, 213–214, 223, 256, 314, 320,
 328
 and attention, 29–31
 and perception, 13–14
 Cappie, James, 17
 Caravaggio, Michelangelo Merisi da,
 112–113
 Carnival, 237–238, 369
 Carpenter, William B., 21, 22n27, 63, 169n41
 Carroy, Jacqueline, 232n193, 235n195
 Cassirer, Ernst, 18n17, 48n107, 56, 95,
 320n85
 Castoriadis, Cornelius, 17n14
 Cattell, James McKeen, 29n46, 43, 307–308,
 311n64, 314n71
 Cezanne, Paul, 9, 27, 92, 126, 150, 281–289,
 297–301, 307, 315–316, 320, 328–335,
 337–344, 347, 351–359, 368
 Banks of a River, 353
 Madame Cezanne in the Conservatory,
 92
 Mont Sainte-Victoire, 288
 Rocks and Pines, 6, 329–334, 337–340
 Study of Foliage, 356
 Chaignet, Anthelme Edouard, 205n126
 Chapman, James, 37n74
 Charcot, Jean-Martin, 23, 66, 100, 105n50,
 166–167, 230n188, 232, 235–236, 294
 Charisma, 203, 246
 Châstel, Andre, 222
 Cheret, Jules, 229n185, 269, 270n276
 Chertok, Leon, 69n170, 230n189, 235n195
 Chevreul, Eugene, 226
 Chion, Michel, 23n28, 290n21
 Churchland, Patricia Smith, 34n59
 Cinema, 5, 13–14, 31–32, 50, 52, 68, 71, 77,
 129, 138, 148, 156, 191, 238, 249, 254,
 259–260, 278, 282, 306–307, 325, 340,
 343–347, 366, 369–370
 The Great Train Robbery, 345–347
 as industrial art, 273, 358
 Kinetoscope, 31, 136
 L. and A. Lumiere and, 266–267
 Reynaud and, 259–270, 272–278
 Circus, 257, 267, 271
 City, 49, 84, 225, 240–241, 363–367, 370
 Clark, T. J., 97, 179n68
 Class, social, 97, 185–186, 198, 243
 Clay, Jean, 88n10
 Clayson, S. Hollis, 224n173
 Cohen, Hermann, 15n8
 Coleridge, Samuel T., 35n67
 Collier, Leslie Jo, 251n250
 Color, 83n3, 110, 127, 156–157, 159–160,
 170n43, 171n45, 174, 198, 204, 223,
 226, 258, 298, 339
 as inference, 159

- Color (*cont.*)
 nonoptical models of, 166–167
 in Seurat, 156–157, 159, 161, 258
 varying range of sensitivity, 294
- Columbia University, 307
- Commodity, 115, 117, 119, 121–122, 125, 129, 133–134, 257
- Communication, 14, 31, 37, 76, 78, 141–142, 182, 242, 246, 370
- Community, 44, 51, 62, 248, 251, 355
- Comolli, Jean-Louis, 273
- Complexity, 181, 299, 318
- Computer, 37, 74–75, 309
- Comte, Auguste, 181–182
- Condillac, Etienne de, 18
- Conjugalality, 106–108, 110
- Connor, Steven, 23n28
- Consciousness, 16, 18, 24, 26, 34n61, 38, 43–44, 48, 55–63, 66, 101, 278, 283–285, 307, 326
 bypassing of, 40, 58, 169–170
 nonidentity of attention and, 43–45, 294
 topological models of, 291–293
- Consumption, 31, 37, 64, 78, 119–126, 131, 134, 136, 184, 193, 195–196, 198, 203, 245, 287, 369
 attention and, 2, 33, 117–118
 distraction and, 122, 248
 perceptual, 131, 138, 148, 309, 318, 326
- Contemplation, 7, 46, 50, 54, 224, 248, 278
 and aesthetic construction, 299
- Contrapposto, 227–229
- Control, social, 43, 45, 53, 63, 70, 73–76, 244, 246–247
- Corbin, Alain, 109n61
- Cornford, F. M., 207n135
- Courtine, Jean-Jacques, 99
- Cousin, Victor, 15n6, 20
- Croce, Benedetto, 204n124
- Crowd, 241–247, 257, 365, 367, 369
- Cubism, 344
- Dagognet, François, 144, 167n39, 259n268
- Daguerre, Louis J. M., 136, 251
- Dahlhaus, Carl, 279n284
- Damasio, Antonio, 34
- Damisch, Hubert, 191n94
- Damrosch, David, 367n10
- Danziger, Kurt, 29n46, 292n23
- Darwin, Charles, 40, 99, 174
- Daston, Lorraine, 18n15, 27n41, 43
- Dayan, Daniel, 184n83
- Daydream, 5, 57, 77–78, 97, 100–101, 138, 327
- Death instinct, 211
- Debord, Guy, 73–74, 76n187, 126, 184n83, 185, 187n86, 245, 369
- Debussy, Claude, 155n9
- Decadence, 122, 124, 173–174
- De Cauter, Lieven, 238n203
- Decentering, 294, 335, 337, 354, 357
- Decker, Hannah S., 96n30
- Degas, Edgar, 9, 131n105, 224
- Degeneration, 17n12, 176
- De Grazia, Sebastian, 54n122
- Dehistoricization, 113n71, 146–147, 152, 186, 211, 362, 369
- Delacroix, Eugene, 223
- Delboeuf, Joseph, 23n30, 101, 323n94
- Deleule, Didier, 302n43
- Deleuze, Gilles, 9, 75–76, 92, 93n19, 110n63, 126, 129, 142, 218n162, 244n225, 286, 298n33, 323, 324n100, 338, 340, 347, 354, 358
- Derrida, Jacques, 4, 190n90, 200, 218n160, 283, 288n18, 337–338
- Descartes, Rene, 17n15, 56, 57, 86, 292, 352
- Deslandes, Jacques, 269n274
- Dewey, John, 22n27, 24, 49n111, 126n93, 155n9, 170n43, 317, 352n162
 “The Reflex Arc Concept,” 313–315
- Didi-Huberman, Georges, 225n175
- Diggins, John Patrick, 314n72
- Diller, Lawrence H., 36n72
- Dilthey, Wilhelm, 15, 23n30, 58–59, 131n105, 284n11
- Diorama, 136, 251–252, 258
- Disenchantment, 150, 196, 206
- Dissociation, 15, 46, 57, 66–67, 77, 96, 102, 126, 131, 134, 183n79, 285
 Bergson on, 326–327
 Janet on, 95–96

- and narrowed attention, 100
 as perceptual dispersal, 94
 relation to synthesis, 92
 spectacle and, 148
 Distraction, 1, 14, 30, 40, 57, 94, 103, 105–
 106, 117, 122, 248–252, 315
 relation to attention, 46–51
 Divisionism, 159–160, 208–209, 226
 Dodds, W. J., 337n121
 Dorra, Henri, 204n122, 271n278
 Dragonetti, Roger, 119n81
 Dream, 94, 129, 147–148, 208, 242, 252,
 299, 323–326, 368
 Duchamp, Marcel, 107n55, 159
 Du Maurier, George, 70n173
 Durer, Albrecht, 213
 Durkheim, Emile, 47, 155n9, 178–185, 240–
 241, 244n225, 246, 248, 278
 Duve, Thierry de, 159n17, 298n34
 Duvignaud, Jean, 182n74
 Duyckaerts, François, 230n189
 Dynamogeny, 163–168, 170–172, 174, 177,
 205, 209–210, 239, 244, 272

 Eagleton, Terry, 57, 117n75, 349n154
 Earthly paradise, 91, 145, 356
 Ebbinghaus, Hermann, 23n30, 45n94, 303
 Eccles, John C., 34
 Edelman, Gerald, 34n59
 Edison, Thomas, 31–33, 260, 272
 Edison Company, 345
 Ehrenfels, Christian von, 155–157, 158n15
 Ehrenzweig, Anton, 160n22, 300n41
Einfühlung, 172n50
 Eisenman, Stephen F., 179n68
 Eisenstein, Sergei, 172n48, 198n106, 222
 Elderfield, John, 297n30
 Electricity, 27, 164, 310, 314
 Ellenberger, Henri, 165n32, 172n49
 Elsaesser, Thomas, 209n139
 Empathy theory, 158, 172n50
 Empiricism, 315
 Engels, Friedrich, 199n110
 Entoptical phenomena, 215–218, 220
 Entropy, 184, 332
 Enzensberger, Hans Magnus, 54n122

 Epistemological crisis, 14, 62, 65, 155, 320
 Epistemology, 18, 44, 56–57, 60, 245, 310,
 321
 Ewald, François, 181
 Exner, Sigmund, 165n31
 Ey, Henri, 62n149

 Faciality, 92–93, 99
 Facilitation, 165n31, 336
 Fairgrounds, 236, 238
 Fancher, Raymond E., 334n117
 Fantasy, 208–209, 214, 238, 256
 Farah, Martha J., 94n23
 Fascism, 358
 Fashion, 108, 115–122, 125, 243
 Featherstone, Mike, 238n202
 Fechner, Gustav, 12, 23, 26, 47n100,
 68n169, 169n41, 204, 302
 Fèher, Michel, 76n186
 Feneon, Felix, 158n16, 192n97, 258n267
 Fere, Charles, 39, 165–168, 172–174, 176–
 177, 182n72, 309n59
 Ferrier, David, 41
 Fetishism, 104, 115, 129, 134
 Fiedler, Konrad, 46, 48, 51n114
 Figlio, Karl M., 18n16
 Figure/ground, 93, 160, 294–295, 342, 347
 Film. *See* Cinema
 Flanagan, Owen, 352n161
 Flaubert, Gustave, 166n33
 Fliess, Wilhelm, 111
 Forgetting, 41, 52, 57, 100, 203, 299, 327,
 362
 Foster, Hal, 74n185
 Foucault, Michel, 4, 12n1, 29, 45, 73–76,
 97n31, 128, 142n117, 184n82, 257, 286,
 310–311
 Fouillee, Alfred, 47, 177n64, 294n26
 Fovea, 290, 295, 340
 Francastel, Pierre, 188n87, 359
 Freedom, 25, 45, 71, 117, 118–119, 152,
 317, 319, 323, 336, 358
 Freud, Sigmund, 23, 25–26, 39, 42, 58, 68,
 69, 71, 96, 100, 105, 111, 129, 155n9,
 211, 235, 246, 334–338, 350n156,
 363–370

- Freud, Sigmund (*cont.*)
The Interpretation of Dreams, 129, 134
 "Project for a Scientific Psychology," 23,
 129, 165n31, 334–338
- Fried, Michael, 90, 92n17, 100n36, 104n49,
 241n212
- Friedberg, Anne, 137n109
- Fry, Roger, 158n16
- Fuhrmann, August, 134, 136, 273
- Fulcher, Jane, 252n253
- Galison, Peter, 27n41
- Galton, Francis, 215n155
- Gane, Mike, 181n70
- Garelick, Rhonda, 119n81
- Gasquet, Joachim, 341n134, 342n136
- Gates, Bill, 33
- Gaudreault, Andre, 345n145
- Gauld, Alan, 235n197
- Gearhart, Suzanne, 18n17
- Gedo, Mary Mathews, 191n96, 224n173
- Gehlen, Arnold, 318n82
- Gericault, Theodore, 276n283, 277
- Gervex, Henri, 106n53
- Gestalt psychology, 155–158, 160, 180, 311,
 313
- Gibson, James J., 306n52
- Gilbert-Rolfe, Jeremy, 90n14
- Gilles de la Tourette, Georges, 70n174,
 235n194
- Godfrey, Sima, 119n81
- Goethe, Johann Wolfgang von, 153, 226
- Goldstein, Jan, 20, 38n75
- Goldstein, Kurt, 47n100, 95, 290n20,
 349n151
- Goldwater, Robert J., 191n92
- Gombrich, E. H., 300n38
- Goodman, Nelson, 300
- Gotlieb, Marc C., 277n283
- Gould, Jay, 144
- Goux, Jean-Joseph, 194n101
- Gowing, Lawrence, 287n17, 289n19
- Gravelines (France), 175, 177
- Green, Andre, 201n116
- Greenhalgh, Paul, 231n191
- Gregory, R. L., 216n158
- Grosz, Elizabeth, 110n63, 219n164
- Guattari, Felix, 75–76, 77n190, 92, 110n63,
 190n90, 244n225, 338
- Gunning, Tom, 25n34, 191, 271, 369n18
- Gurwitsch, Aron, 295n27
- Guyau, Jean-Marie, 177
- Haas, Robert B., 145n120
- Habit, 292, 318–319
- Hacking, Ian, 96n28, 162
- Hall, G. Stanley, 15, 22n27, 58n134, 66,
 235
- Hall, Harrison, 283n9
- Halperin, Joan U., 158n16
- Hansen, Carl, 235
- Hansen, Miriam, 49n108
- Harman, P. M., 183n78
- Harmony, 175, 178–179, 203, 205–206,
 210–211, 227, 279
- Haroche, Claudine, 99
- Harrington, Anne, 39n79, 156n10
- Hartman, Geoffrey, 299n37
- Hartmann, Eduard von, 22n27, 321n89
- Harvard University, 29n45, 171
- Harvey, David, 142
- Hatfield, Gary, 19n19
- Hausmann, Georges, 84, 365
- Hayes, Denys, 229n184
- Head, Henry, 34n60
- Hearing, 1, 3, 23n28, 46, 48, 249, 290n21,
 310, 313, 351
- Hearnshaw, L. S., 34n60
- Hegel, Georg Wilhelm Friedrich, 25n32,
 64n157, 70n172, 79
- Heidegger, Martin, 44, 54n121, 173n54
- Helmholtz, Hermann von, 12, 23n30, 64,
 104n50, 153, 159, 215–218, 220, 242,
 290n20, 301n42, 309–310, 319–323,
 325, 335
Treatise on Physiological Optics, 30, 215–
 217, 284, 291
- Hendricks, Gordon, 145n120
- Henry, Charles, 164–165, 170, 175–176,
 177n63, 196n102, 200, 205, 239
- Henry, Michel, 57n131
- Herbart, Johann Friedrich, 55n124, 58
- Herbert, Robert L., 153n7, 163n27, 191n94,
 201n117, 241n213, 269n273

- Hering, Ewald, 23n30, 290n20
Hertel, Christiane, 128n98
Hertz, Heinrich, 162–163
Hewitt, Andrew, 186n85
Hildebrand, Adolf, 295
Hoch, August, 324n99
Hochberg, Julian, 33n59, 290n20
Hofmannsthal, Hugo von, 328
Holbein, Hans, 158
Holenstein, Elmar, 25n35
Holland, Eugene W., 110n65
Hollier, Denis, 186n84
Holmes, Frederic L., 310n61
Homeostasis, 211, 278, 281, 342
Hopp, Gisela, 127n97
Horkheimer, Max, 53
Hubel, David, 337n121
Hulme, T. E., 46
Human sciences, 9, 45, 70
Humbert de Superville, D. P. G., 163n26, 223, 228n182
Hume, David, 18
Husserl, Edmund, 155n9, 190n90, 282–287, 288n18
 Logical Investigations, 22n27, 283, 285
Hutton, John G., 154n7
Huxley, Aldous, 52n117, 290n21
Huxley, Thomas H., 230n188
Huysmans, Joris-Karl, 94
Huysen, Andreas, 247n240, 328n110
Hypnagogic vision, 325
Hypnosis, 65–71, 100–101, 105, 114, 230–239, 241–242, 246, 252
 ambiguity of, 69, 230–231
 art and, 239–240
 and dissociation, 67–68
 exhibitionary status of, 231–236
Hysteria, 94, 96, 99, 112, 126, 166
- Iamblichus, 205n128
Impressionism, 51
Indexical signs, 114–115
Inhibition, 38–41, 115, 163–166, 209, 239, 292, 322, 351
Intentionality, 284
Intersubjectivity, 51, 87, 125
Introspection, 20–21, 43, 54, 79, 283, 307
Isaacson, Joel, 339n125
Ives, Frederic Eugene, 117
- Jackson, John Hughlings, 38n77, 95, 101–102, 138n110, 148, 165
James, William, 23, 26, 27, 29n40, 42–43, 60–64, 68, 100n38, 127n96, 170–171, 180n70, 216, 284n10, 295, 304n50, 314–315, 349, 361–362
 Principles of Psychology, 60n141, 101, 158, 361
Jameson, Fredric, 30n48, 150–151, 327n108, 357n172
Janet, Pierre, 23n30, 39, 42, 69n171, 95–96, 100, 104, 105n50, 126, 155n9, 180n70, 184, 230n188, 294, 323–324, 326
Jaspers, Karl, 349n152
Javal, Emile, 291
Jay, Martin, 190, 284n11, 326n103, 362n2
Jaynes, Julian, 71n175
Jeannerod, Marc, 348n148
Jencks, Chris, 179n67
Jevons, W. Stanley, 304n50
Johnson, Barbara, 119n82
Johnson, James H., 249n247
Jonas, Hans, 291n21
Jullien, Adolphe, 255n259, 256n262
Junger, Ernst, 171
- Kafka, Franz, 50n112, 224n173
Kahane, Martine, 252n253
Kahn, Douglas, 22n28
Kahn, Gustave, 205, 236n200, 258
Kahneman, Daniel, 78n192
Kaiserpanorama, 134–138, 147
Kaleidoscope, 60, 347, 350, 354
Kandinsky, Wassily, 159
Kant, Immanuel, 14–16, 19, 38, 48, 56, 57, 292, 361n1
Karatani, Kojin, 200
Katz, Elihu, 184n83
Kemp, Martin, 169n40
Kepler, Johannes, 223n171
Kern, Stephen, 310n62
Kernodle, George R., 191n94

- Kinetoscope, 31, 136
 Kirby, Lynne, 345n144
 Kittler, Friedrich, 248n240, 302n44, 303
 Kline, Morris, 206n130
 Klinger, Max, 91, 128–134, 137, 148
 Koestler, Arthur, 78, 298n35
 Köhler, Wolfgang, 156n9, 157, 300
 Kohnke, Klaus, 15n8
 Koppen, Erwin, 252n253
 Kosslyn, Stephen M., 34n59
 Kracauer, Siegfried, 48, 146, 345n143
 Krafft-Ebing, Richard von, 115, 235
 Kramer, Lawrence, 87n8
 Krauss, Rosalind, 46, 190n90, 214, 331n113
 Kristeva, Julia, 106, 110, 212n147, 339n127
 Kubie, Lawrence S., 325n102
 Kuhn, Thomas S., 335n120
 Kulpe, Oswald, 16, 23, 367n13
 Kunzle, David, 93n20
 Kusch, Martin, 284n11
- Labor, 13, 14n3, 30, 41, 72n179, 78, 108,
 138, 145, 204, 309, 320
 division of, 182
 Lacan, Jacques, 4, 87, 212n146, 218n161
 Lacoue-Labarthe, Philippe, 222n168, 256
 Ladd, George Trumbull, 16n11, 22n27,
 171n46, 291n22
 Lafontaine, Charles, 232n193
 Langer, Ellen J., 317n80
 Laplanche, Jean, 23n28, 107n56, 165n31,
 208, 211n143, 311, 368
 Lawrence, D. H., 343n137
 Laycock, Thomas, 169n41
 Leary, David E., 25n35
Lebensphilosophie, 55, 311, 318
 Lebensztein, Jean-Claude, 150n1, 236n200,
 255n260
 Le Bon, Gustave, 240, 242, 245–247, 370
 Le Brun, Charles, 99
 Lecercle, Jean-Pierre, 119n81
 LeDoueff, Michele, 207n135
 Lefebvre, Henri, 74n183, 366n7
 Lehmann, Henri, 193n98
 Leibniz, Gottfried Wilhelm, 19, 292
 Leisure, 77–78, 128
 Lemaire, Michel, 119n81
- Lenoir, Timothy, 27n40, 321n89
 Lentricchia, Frank, 362n3
 Leonardo da Vinci, 158, 166n33, 191–194,
 199, 201, 208n136, 229n187, 299
 Leontis, Artemis, 362n2
 Leppert, Richard, 203n119
 Levin, David J., 104n46, 248n242
 Levine, Steven Z., 344n140
 Levi-Strauss, Claude, 177n66, 199
 Liebeault, Auguste, 66–67, 68n169
 Liebig, Justus von, 320
 Liegeois, Jules, 70n174
 Light, 16n11, 27, 161–162, 166–167, 209,
 225, 227, 254, 258
 modern reconceptualization of, 170
 Seurat and, 152–153
 Lindholm, Charles, 246n234
 Lingis, Alphonso, 160n21
 Lipovetsky, Gilles, 117n76
 Lipps, Theodor, 23, 64, 172n50, 284n11
 Lissauer, Hermann, 94n23
 Liszt, Franz, 256n262
 Livingston, James, 61n146
 Livingstone, Margaret, 337n121
 Locke, John, 18, 19n18
 Loewy, Emanuel, 228n182
 Lombroso, Cesare, 35n65
 Londe, Albert, 306n51
 London, Perry, 71n176
 London International Exhibitions (1871–
 1872), 121–124, 200
 Lotze, Hermann, 20
 Louvre (Paris), 112, 113n71, 356
 Luckmann, Thomas, 318n82
 Lucretius (Titus Lucretius Carus), 299
 Lukacs, Georg, 327n107
 Lukes, Steven, 318n83
 Lumiere, Louis and Auguste, 245n229,
 266–267
 Lyotard, Jean-François, 214, 218–220, 334
- Mach, Ernst, 23, 28, 29n44, 47n102, 104n47,
 111n67, 142, 157, 162–163, 216n158,
 220–221
 Madness, 24, 324
 Magic lantern, 55, 251, 274, 366
 Magic shows, 232, 251, 254, 264

- Mahler, Gustav, 155n9, 248n241
 Maine de Biran, François-Pierre, 20
 Maldiney, Henri, 340
 Malebranche, Nicolas, 17n14, 50n112
 Mallarme, Stephane, 44, 83–84, 119–125, 127n95, 200, 248, 255
La Dernière Mode, 119–125
 Manet, Edouard, 9, 82–94, 97–118, 125–131, 148, 149, 281, 288, 297, 332, 359, 362, 370
The Balcony, 82–88, 104, 370
Bar at the Folies-Bergere, 86
Before the Mirror, 88, 109–110
Chez le Pere Latbuille, 102–103, 107n57
In the Conservatory, 5–6, 90–94, 97–117, 125–129, 131n105, 209, 332, 356
The Reader, 88
Self-Portrait with Palette, 88
Skating, 131
Spring, 117n76
 Mann, Thomas, 222
 Mannoni, Laurent, 259n268
 Marey, Etienne-Jules, 138, 140, 161–162, 166n34, 167, 267, 269, 271, 277, 350, 357
 Marillier, Leon, 22n27, 64n155, 126n93
 Marin, Louis, 113n71
 Marinetti, Filippo Tommaso, 171
 Marx, Karl, 13n3, 54, 140–142, 145n122, 196–198, 214
 Maslow, Abraham, 41n86
 Mathematics, 205, 207, 213, 218, 223, 311
 Matisse, Henri, 159
 Matrix, 212–214
 Matson, Floyd W., 313n66
 Matsuda, Matt K., 95n26
 Mattelart, Armand, 142n116
 Maudsley, Henry, 17n12, 21, 22n27, 41n85, 58
 Maupassant, Guy de, 70n173
 Maury, L.-F. Alfred, 147
 Mavromatis, Andreas, 325n102
 Maxwell, James Clerk, 183
 Mayer, Julius, 320
 McCarren, Felicia, 27n40
 McGhie, Andrew, 37n74
 McGrath, William J., 248n241
 McLuhan, Marshall, 200n114, 226n177
 Mead, George Herbert, 20, 23n30, 43n88, 313n66
 Meissonier, Ernst, 277n283
 Melies, Georges, 155n9
 Memory, 15, 27, 203, 314, 318–319, 321–322, 324–325, 327, 334–339, 362
 Merleau-Ponty, Maurice, 33n59, 282, 311, 341, 349n153
 Mesmer, Franz Anton, 68, 70n172, 235n194
 Mesulam, M. Marsel, 337n121
 Metz, Christian, 77, 175n60
 Meusy, Jean-Jacques, 259n268
 Meyerson, Emile, 26n39, 155n9
 Micale, Mark S., 69n171
 Mill, James, 20n22
 Mill, John Stuart, 20, 284n11
 Miller, Jonathan, 40
 Milner, John, 270n276
 Minkowski, Eugene, 326n105
 Mintorn, William, 70n173
 Mitchell, Timothy, 236n199
 Modernism. *See* Art, modernist
 Modernity, 19, 48–49, 53–54, 181–182, 193, 196, 203, 223, 369
 Durkheim and, 184–185
 Kant and, 14
 Modernization, 12–14, 17, 30, 33, 36, 107, 115, 140–144, 164, 201, 314, 327–328, 357, 365–366
 Marx on, 140–142
 Moholy-Nagy, Laszlo, 222
 Moll, Albert, 66n164, 235n194, 239
 Mondrian, Piet, 159
 Monet, Claude, 9
 Monomania, 134
 Moretti, Franco, 61
 Morghen, Raphael, 191n95
 Morisot, Berthe, 87
 Morse, Samuel F. B., 33n57
 Moscovici, Serge, 242n218
 Mosso, Angelo, 22n27, 41, 64n157
 Motor activity, 20n20, 41–42, 67, 164, 167, 277n283, 309, 313–315, 317, 323–324
 perception and, 41–42, 169, 301, 315, 348–354, 357
 Sherrington on, 348, 350–352
 Müller, Johannes, 153, 214, 216n158
 Müller-Lyer lines, 285

- Münsterberg, Hugo, 43, 63n153, 74n182
 Musée Grevin (Paris), 259, 265–266,
 270n276
 Music, 156, 203–207, 249, 251, 253–254,
 281, 339
 Musser, Charles, 345n144
 Muybridge, Eadweard, 92, 138–148, 267,
 269n274, 271, 273, 276, 277n283, 306
 Myers, Gerald E., 43n87
 Myth, 181, 256–257, 279

 Nancy, Jean-Luc, 236n198
 Nattiez, Jean-Jacques, 211
 Necker cube, 285
 Neisser, Ulric, 302n46
 Neoimpressionism, 155, 159–160
 Dewey on, 170n43
 Nervous system, 102, 114, 164–165, 167,
 170–171, 210, 239, 243, 295, 319, 344,
 348, 349n153, 350, 352
 Neurology, 23, 34, 36, 165, 282
 Nietzsche, Friedrich, 15, 27, 44, 45n93, 52,
 54, 84, 122, 124, 126, 163, 170n44, 201,
 213n148, 247, 250n248, 252–253, 301,
 320, 343, 354
 and Seurat, 172–176, 177n64, 201, 205
 Nihilism, 126, 198, 320
 Nochlin, Linda, 179n68, 274n282
 Nord, Philip, 166n33
 Nordau, Max, 16, 30, 35, 171, 250n248
 Novelty, 30, 33, 49n111, 77, 138, 327–328,
 338
 attention sustained by, 126
 Novotny, Fritz, 341
 Nye, Mary Jo, 245n229

 Obersteiner, Heinrich, 22n27, 35n65
 Oettermann, Stephan, 134n108, 136
 Olin, Margaret, 52n115
 Ong, Walter J., 23n28
 Opera, 248–249, 254
 Optics, physiological, 4, 56, 153–155, 214–
 218, 290–292, 295
 Ortega y Gasset, Jose, 292n24

 Panorama, 134–136, 251, 255, 295
 Paradis, Bruno, 319n84
 Parinaud, Henri, 105n50
 Park, Katharine, 18n15
 Pashler, Harold E., 4n3, 33n59
 Pater, Walter, 327–328
 Pavlov, Ivan, 348, 349n153
 Peep show, 136
 Peirce, Charles Sanders, 27, 44, 59–60, 113–
 115, 159, 206n131
 Pemberton, Christopher, 341n134
 Perception, 3–5, 9–10, 12, 22, 29–30, 32, 39,
 44, 92, 94–97, 100–101, 104–105, 108,
 128, 153, 282, 290, 315, 329
 aesthetic, 2, 7, 27, 45, 177
 Bergson on, 322–327, 334–338
 crisis in, 2, 129, 155
 desymbolization of, 94–95, 289
 dispersal of, 92, 94, 104–105, 108, 138,
 150, 288, 324
 Freud on, 334–338
 Gestalt theories of, 155–158, 160
 modernization of, 5, 13–15, 29, 126, 138,
 140–144, 147–148, 222, 227, 271,
 277–278, 343–348, 357–359
 nonreferential models of, 155, 355
 normative, 100, 311, 324
 premodern, 48–49, 51, 273
 pure, 27, 46, 57, 282, 301, 306, 315–316,
 328
 Periphery, visual, 40, 108, 290, 293–298, 366
 Perrot, Michelle, 14n3
 Perrot, Philippe, 121n83
 Perspective, 189, 190–191, 199
 Petro, Patrice, 78n194
 Phantasmagoria, 251, 254–255, 257, 261,
 264, 279
 Phenakistoscope, 263, 271, 272
 Phenomenology, 158, 282, 286, 349n153
 Phidias, 158, 205
 Phonograph, 32
 Photography, 13, 68, 117, 131n105, 136,
 138–147, 156, 255, 259, 276, 304, 306
 Physics, 162, 174, 321
 Physiology, 153, 176–177, 210, 240, 284,
 310, 319, 337
 Pick, Daniel, 17n12

- Piero della Francesca, 158
 Piranesi, Giovanni Battista, 366
 Planck, Max, 155n9
 Poe, Edgar Allan, 196n102
 Polyani, Michael, 206n130, 297
 Pomian, Krzysztof, 18n15
 Pontalis, J.-B., 23n28, 107n56, 165n31, 208, 368
 Popper, Karl, 34
 Porter, Edwin S., 345–347
 Porter, Theodore, 29n44
 Positivism, 155
 Posner, Michael I., 34n63, 286n13
 Posnock, Ross, 63n152
 Postman, Leo, 303n47
 Postman, Neil, 33n57
 Poussin, Nicolas, 113n71, 298
 Praxinoscope, 260–264, 267, 269
 Presence, 4, 45, 46, 48, 59, 65, 119, 126, 224, 227, 278, 303, 315, 328, 336
 Pribram, Karl H., 350n156
 Prigogine, Ilya, 321n88
 Psychoanalysis, 68, 367
 Psychologism, 284
 Psychology, scientific, 13, 15, 21, 23–29, 42–43, 45, 97, 171–172, 290–295, 302–315, 337
 Psychometry, 26–27, 307
 Psychophysics, 12, 155, 284, 307
 Purkinje, Jan, 214
 Puvis de Chavannes, Pierre, 205
 Pythagoreanism, 205–207, 210, 223
- Rabinbach, Anson, 166n34, 320
 Railroad, 140, 271
 Rajchman, John, 174n57, 342n135
 Ramon y Cajal, Santiago, 295n28
 Rapaport, Herman, 208n138
 Rationalization, 147–148, 150–152, 201, 204, 210, 222–225, 311, 350
 of art practices, 196, 226
 of emotional response, 152, 154, 163, 175–176, 240, 255, 278
 of labor, 204, 309
 Raymond, Marcel, 102n43
 Reaction time, 25, 27, 307–310
 Realism, 91–92, 134, 138, 162
 Reality effects, 140, 146, 148, 265, 274
 Reality function, 95–96, 102
 Reed, Edward S., 21n25, 362n2
 Reflex, 25, 42, 164, 170–171, 311–313, 317, 348
 conditioned, 312
 Regression, 15, 208, 229, 231, 246, 252, 278
 Jackson and, 101–102
 and spectacle, 238
 Reid, Thomas, 20n22
 Reification, 327
 Rembrandt van Rijn, 51, 161, 201n117
 Renouvier, Charles, 206n129
 Representation, classical, 201, 218–220, 287, 299, 310
 Repression, 26, 39, 57, 96
 Retina, 16n11, 152–154, 162, 167, 216–218, 220, 242–243, 290–291, 297
 Reverie, 3, 46, 78, 97, 101–102, 119, 138, 299, 327
Revue wagnerienne, 253
 Rewald, John, 329n111
 Reynaud, Emile, 259–270, 272–278
 Rhythm, 88, 110, 134, 138, 147, 309, 315n74, 339–340, 343n138, 345
 Ribot, Theodule, 16, 23, 35, 47n99, 61n143, 64, 134n107, 164, 292n23, 322
 Richard, Jean-Pierre, 119n81
 Richet, Charles, 66n162, 70n173
 Ricoeur, Paul, 104, 334n118
 Riegl, Alois, 51–52, 155n9, 218, 340
 Riesman, David, 53
 Rilke, Rainer Maria, 49, 297
 Rimbaud, Arthur, 215n155, 355n168
 Rochlin, Gene I., 33n58
 Rodin, Auguste, 49
 Rodowick, D. N., 76–77n189
 Rookmaaker, H. R., 154n7
 Ropars-Wuilleumier, Marie-Claire, 345n142
 Rorty, Richard, 44, 60
 Rosand, David, 206n132
 Rose, Jacqueline, 208n136
 Rose, Nikolas, 308n56
 Rosenblatt, Nina Lara, 177n65
 Ross, Dorothy, 58n134, 235n195
 Ross, Kristin, 355n168
 Rotman, Brian, 198
 Rouget, Gilbert, 231n192
 Rousseau, Jean-Jacques, 218n160, 327, 355

- Rousseau, Pascal, 167n39
 Roustang, François, 235n198
 Routinization, 77, 203, 316
 Rouvier, Catherine, 246n234
 Rowe, Colin, 367
 Rubens, Peter Paul, 298, 356
 Ruskin, John, 282n2, 322n91, 327, 328n109
 Russell, John, 201n117
 Ryle, Gilbert, 35n64
- Sacks, Oliver, 94n23, 334n118
 Sadoff, Diane F., 166n34
 Sadoul, Georges, 259n268
 Safranski, Rudiger, 57
 Salon painting, 255
 Salpetriere (Paris), 66, 100, 166, 232
 Sartre, Jean-Paul, 325n101
 Sass, Louis A., 300
 Saussure, Ferdinand de, 155n9
 Scenography, 188, 190–191, 204, 214, 218, 228, 257, 278
 Schapiro, Meyer, 198n105, 222, 229, 272, 281, 339, 357n173
 Scharf, Aaron, 269n274
 Schelling, F. W. J., 68n168
 Schiller, J. C. Friedrich, 368n15
 Schivelbusch, Wolfgang, 225n176, 251n249
 Schizophrenia, 37–38, 183n79, 326
 Schlanger, Judith, 158n15
 Schoenberg, Arnold, 222, 347
 Schopenhauer, Arthur, 15, 42, 55–58, 211, 249n246, 282n2, 315n75
 Schwartz, Hillel, 238n203, 315n74
 Schwartz, Sanford, 318n81
 Schwartz, Vanessa, 259n268, 265n271, 270n276
 Sechenov, Ivan, 169n41
 Sedlmayr, Hans, 341
 Seebohm, Thomas M., 284n11
 Sennett, Richard, 249n247
 Sensation, 26–29, 111, 167–169, 344
 classical theories of, 18
 without perception, 306
 Separation, 2–3, 74, 79, 84, 86, 185–186, 194, 203, 211
 and anomie, 182–183
 Serres, Michel, 190n90, 226n179
- Seurat, Antoine-Chrysostome, 224n173
 Seurat, Georges, 9, 27, 149–156, 158–165, 169–170, 172, 174–179, 181, 184–214, 217–230, 236–241, 243–244, 246, 248, 255–259, 267–280, 281, 297, 342, 348, 358–359, 362
Chabut, 150n1, 210, 212
The Channel at Gravelines, Evening, 177, 178
Cirque, 150n1, 179, 181, 210, 212, 240, 243–244, 267–271, 273–278
Parade de cirque, 5, 150–154, 156, 163, 175–178, 181, 187–214, 217–220, 223, 225, 227–229, 236–241, 243–244, 246, 366
Place de la Concorde, Winter, 185–186, 365
A Shop and Two Figures, 195–196
Solitary Figure, 183
Sunday Afternoon on the Island of La Grande Jatte, 179–180, 199, 257
Une baignade, Asnieres, 199
- Shaviro, Steven, 344n141, 358n177
 Shenk, David, 33n58
 Sherrington, Charles S., 95, 155n9, 294, 348–352, 354
 Shiff, Richard, 330, 334n115, 340n129
 Shock, 49n111, 50, 88, 129, 306, 314–315, 322, 349, 365
 Sicard, Monique, 357n174
 Sieburth, Richard, 252n253
 Siemens, Werner von, 31n55
 Signac, Paul, 190n90, 225, 258n267
 Silverman, Deborah, 231n190
 Silverman, Kaja, 211n144, 212n146
 Simmel, Georg, 48, 97, 102, 108, 117, 155n9, 223, 240, 348, 365
 Sitte, Camillo, 365
 Sleep, 57, 65n159, 66, 105, 147, 325
 Smith, John H., 94n22
 Smith, Paul, 207n134, 241n213, 247n239
 Smith, Roger, 38n78, 41n84, 164n29, 348n148
 Social cohesion, 14, 35, 177, 181–182, 184, 241
 Sociology, 185–186, 240
 Sola-Morales, Ignasi de, 51n114

- Solidarity, 176, 179, 181–185, 187, 278
 Sollers, Philippe, 355n168
 Solso, Robert L., 290n20
 Somnambulism, 97, 100, 129, 147, 239, 242, 358
 Sonn, Richard D., 270n276
 Soubies, Albert, 253n255
 Souriau, Paul, 254
 Spectacle, 2, 13, 73–76, 79, 122, 124, 148, 152, 158, 184, 196, 201, 245, 247, 252, 278, 369–370
 and absence, 125–126, 176, 188, 200, 256–257
 and separation, 74–75
 Spencer, Herbert, 20, 42, 131n104, 138n110, 167n36, 171, 309n60, 351n158
 Spengler, Oswald, 318
 Sperling, George, 303n46
 Spiegel, David, 68n166
 Spinoza, Benedict de, 111
 Spivak, Gayatri, 214n152
 Stallybrass, Peter, 236n201, 369
 Stanford, Leland, 140–142, 145
 Stanley, Hiram M., 309n58
 Starobinski, Jean, 3n1
 Stein, Gertrude, 62n148
 Steinberg, Leo, 199n109
 Stengers, Isabelle, 65n161, 69n170, 71n175, 231n192, 321n88
 Stereoscope, 14, 133, 134, 136, 258, 295, 331. *See also* Vision, binocular
 Sternberger, Dolf, 26n37, 137n109
 Stewart, Dugald, 20n22
 Stimuli, 26–27, 29, 78, 152, 163–164, 166–167, 171–173, 175, 292, 302, 304–310, 312–313, 317, 319, 349–352, 365
 as inextensive sensation, 304
 pathological excess, 173, 176
 Stoker, Bram, 70n173
 Stout, George F., 171n46
 Strindberg, August, 70n173
 Stumpf, Carl, 23, 156, 321n89
 Subjectivity, 2–4, 14, 17, 19–21, 30–31, 42, 48, 53, 58, 100, 199, 210, 292
 collective, 150, 177, 188, 230, 240–247, 369
 construction of, 24, 43–45, 72, 99
 normative models of, 57, 97
 quantification of, 302–303
 Subotnik, Rose, 84n5
 Sulloway, Frank J., 335n120
 Summers, David, 227
 Surikov, Vassily, 198n106
 Surveillance, 73, 76
 Sutter, David, 161n23, 189, 192n97
 Swazey, Judith P., 351n157
 Syberberg, Hans-Jurgen, 209n139
 Symbolism, 154, 198, 203, 208, 223
 Synthesis, 9, 15, 20, 38, 48, 57, 79, 100, 104–105, 126, 128, 180, 226, 278, 297, 329, 332
 cinema and, 344–345
 damaged capacity for, 95–97
 Kaiserpanorama and, 138
 Kant and, 14, 56–57, 362n1
 perceptual, 9, 16, 79, 92, 154, 156, 184, 284
 technologies of, 14
 Tachistoscope, 302–307, 310–311, 314, 316
 Tafuri, Manfredo, 366n9
 Taine, Hippolyte, 97n32, 217n159, 294n26
 Tanner, Tony, 108
 Tarde, Gabriel, 240–244
 Taylor, Charles, 63n150
 Taylor, Eugene, 171n45
 Technology, 12, 27, 31–32, 34, 48, 63, 68, 77, 152, 226, 282, 287, 306, 314, 318, 325
 of attraction, 25, 201, 238, 278
 disciplinary, 37, 240
 Telegraph, 33n57, 53, 142
 Television, 13, 31, 37, 71–72, 74–77, 226, 246
 Temporality, 4, 17n14, 43, 45, 46, 52, 58, 110, 140–142, 147–148, 150, 305, 307–311, 322, 353. *See also* Reaction time
 Cezanne and, 298, 353–354
 Dilthey and, 58–59
 Muybridge and, 140–145
 Schopenhauer and, 55–56
 Seurat and, 153–154
 Tenner, Edward, 33n58

- Theater, 124, 188, 191, 218–220, 247–250, 253–255, 257
- Theatre-Optique, 260, 264–266
- Thermodynamics, 165, 183, 226n179, 320
- Thines, Georges, 349n153
- Third Republic, 166n33, 212n147, 230
- Thompson, Richard, 201n117, 239n205
- Tillich, Paul, 50n112
- Tissot, James, 131n105
- Titchener, Edward B., 21, 22n27, 23
- Tonnies, Ferdinand, 52, 74
- Toulmin, Stephen, 226
- Tourneur, Jacques, 238n204
- Trance, 3, 46–47, 57, 65–66, 69, 71, 78, 100, 105, 138, 147, 229, 326–327
non-Western models of, 231
- Transitive states, 60, 295, 362
- Treisman, Anne, 78n192, 286n13
- Trombone, 203n120, 256
- Truesdell, Matthew, 186n84
- Turner, R. Steven, 320n86
- Unconscious, 40, 41, 106, 208, 239
- Unconscious inference, 319, 321–323
- Universal Exposition of 1889 (Paris), 230–232
- Urban space. *See* City
- Utopia, 113n71, 152, 177, 203, 210–212, 356–357
- Vaihinger, Hans, 163
- Valery, Paul, 227, 299, 324n98
- Van der Heijden, A. H. C., 34n59
- Van Ginneken, Jaap, 245n228
- Van Gogh, Vincent, 150, 328n110
- Vanishing point, 198–200, 206–207
- Varela, Francisco, 286n16, 354n166
- Varnedoe, J. Kirk T., 131n105, 132n106
- Vattimo, Gianni, 14, 370
- Velazquez, Diego, 161
- Verhaeren, Emile, 224, 255, 258
- Verhagen, Marcus, 269n273
- Vernet, Joseph, 177n66
- Veron, Eugene, 170, 252
- Vertov, Dziga, 347
- Vidler, Anthony, 366n8
- Virilio, Paul, 71, 226, 304n49, 358
- Vision, 3–14, 40, 46, 48, 87, 92, 103, 105–106, 113, 126–127, 138, 140, 142, 148
as aggregate production, 290–291, 337
autonomous, 12
binocular, 87, 104–105 (*see also* Stereoscope)
and the body, 12–13
Cezanne and, 289, 298–299, 301
classical models of, 20, 24, 40, 83, 86–87, 153, 167, 214, 284, 287 (*see also* Camera obscura model of vision)
field of, 24, 39–41, 104, 258, 290–297
fixed, 297–302, 304
machine, 13, 138, 142–144, 272–274, 278, 303, 341–342, 344–347
Manet and, 126
nonoptical models of, 337, 340, 349
nonveridical status of, 319
Seurat and, 153–155, 217–220, 225
and sexuality, 207–208
subjective, 7, 11–12, 44, 48, 152, 215–218, 220, 230, 289, 301, 309, 335
- Visuality, 2–3, 30, 38–39, 87
regimes of, 11, 153, 190
- Vitalism, 311
- Volition. *See* Will
- Wagner, Richard, 148, 201n117, 208n136, 247–258, 278–279, 343n138
- Ward, James, 20n22
- Ward, Martha, 164n28, 258n266, 280n285
- Weber, Ernst, 323n94
- Weber, Max, 74, 203
- Wehler, Hans-Ulrich, 137n109
- Weiner, Marc, 248
- Wells, H. G., 68n169
- Wernicke, Carl, 94n23
- Wertheimer, Max, 157, 158n15
- West, Cornel, 62n147
- Whistler, James, 100n36
- White, Allon, 236n201, 369
- Whitehead, Alfred North, 56, 155n9
- Wiener, Norbert, 184n81
- Wigley, Mark, 118n78
- Will, 20, 25, 27, 45, 47, 57, 70, 229, 292, 323, 325, 327
and problem of attention, 38, 41–43

- Williams, Alan, 259n268
Williams, Raymond, 31, 74n184
Williams, Rosalind, 243n222
Wing, Paul, 133n108
Winn, Marie, 76n188
Winnicott, Donald, 41n86
Winter, Alison, 21n25
Wittgenstein, Ludwig, 44
Wollen, Peter, 172n48
Woodworth, Robert S., 291n22
Wundt, Wilhelm, 21, 22n27, 23, 29, 38, 41,
51, 64n157, 235, 283, 284n11, 291–292,
294n26, 295n28, 302, 304, 307, 310,
322
Wyzewa, Teodor de, 201n117
- Young, Thomas, 153
- Zeki, Semir, 337n121
Zero, 196–201, 204, 210, 212–213, 247n238,
256
Ziehen, Theodor, 3n2, 22n27
Zielinski, Siegfried, 31n54
Zimmermann, Michael, 164n28, 247n239
Zoetrope, 261, 263, 271
Zone of indetermination, 317–319, 336